

*Powering Business Worldwide*

# Introduction

## 220 Series Piston Pump

Eaton's new 220 Series piston pump signifies a step change in the generation of hydraulic power. Utilizing the latest developments in hydraulic pump technology, the 220 is specifically designed for low flow, high pressure applications. It is currently available in 28cc (1.71 cubic inches) displacement. The 220 is rated for 280 bar and 3,000 rpm making it the ideal pump for an array of different mobile and stationary applications. Capable of generating over 52.6 horsepower (39.2kW), the 220 28cc provides more power in a smaller, compact package. This increased power generation allows equipment manufacturers to design more productive, powerful vehicles with a longer life.

The new 220 design also incorporates many new advances in product reliability. Once equipment is in the field, pump failures can prove to be extremely expensive and costly downtime results. The 220 blends Eaton's long tradition in providing quality pumps with the latest design and technology methods to ensure long lasting product reliability. The result is a very simple design, consisting of almost 25% fewer parts than previously designed pumps.

Eaton employs a unique system of tools and processes, known as Eaton Business System, to ensure quality development and delivery of the 220 product. These tools and process include such known methods as Design for Six Sigma, Lean Manufacturing and ISO certification. Our global network of manufacturing locations and distribution partners enables the 220 to be flexibly configured and delivered throughout the world. Eaton's vision is to be our customer's preferred global supplier of fluid power components. By incorporating the latest advancements in hydraulic pump design and manufacturing, the 220 delivers greater value in terms of power and reliability.

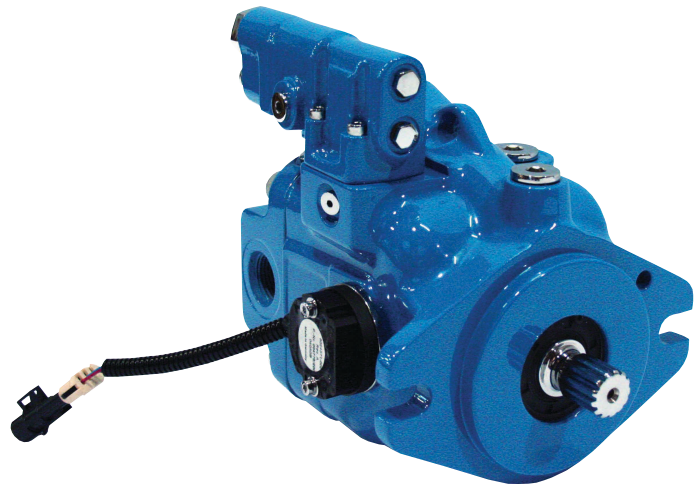

### Typical Applications

- Construction
  - Wheel Loaders
  - Backhoe Loaders
- Agriculture
  - Tractors
  - Harvesting Equipment
- Truck and Bus
  - Salt and Sand Spreaders
  - Vacuum Trucks
- Material Handling
  - Aerial Work Platforms
- Other Mobile
  - Fan Drives

### Features and Benefits

- Lower maintenance costs due to longer pump life and simpler design
- More engine compartment flexibility due to compact size
- Increased hydraulic power per displacement
- Greater fuel savings due to reduced weight and high efficiency design
- Low Noise resulting from low weight and optimized valve plate

# Table of Contents

<b>Model Codes</b>	4
<b>Specifications and Performance</b>	5
<b>Control Options</b>	
Load Sense and Pressure Compensator	6
Pressure Compensator	7
EH Inverse Proportional Pressure Control (IPPC)	8
Remote Pressure Control	9
<b>Performance</b>	
AEC028	10–12
<b>Pump Installation</b>	
B-mount – Rear-ported	13
B-mount – Side-ported	14
Thru-Drive SAE A	15
Thru-Drive SAE B	16
<b>Control Installation</b>	
Load Sense and Pressure Compensator	17
Pressure Compensator	18
EH Inverse Proportional Pressure Control (IPPC)	19
<b>External Manual Stroke Adjustment</b>	20
<b>Input Shaft Options</b>	21
<b>Installation and Start-up</b>	22

# Model Codes

## 220 Mobile Piston Pump

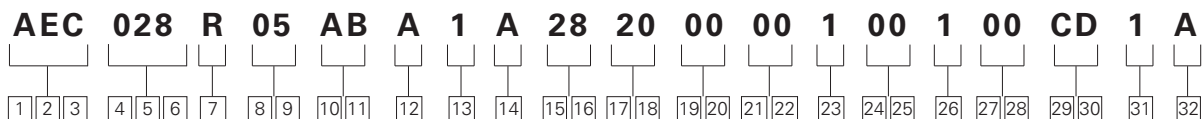

### 1 2 3 Pump Series

**AEC** – 220 Series Open Circuit Piston Pump

### 4 5 6 Pump Displacement

**028** – 28.0 cm<sup>3</sup>/r [1.71 in<sup>3</sup>/r]

### 7 Input Shaft Rotation

**R** – Right Hand  
**L** – Left Hand

### 8 9 Front Mount and Shaft

**05** – 2 Bolt B, 22.2 mm (0.88) Dia. Keyed Shaft  
**09** – 2 Bolt B, 13 Tooth 16/32 Spline  
**31** – 2 Bolt B, 25.4 mm (1.00 in) Dia Straight Keyed  
**34** – 2 Bolt B, 15 Tooth 16/32 Spline

### 10 11 Main Ports Size & Location

**AA** – Rear Port  
Suction - 1.625 - 12 SAE O-Ring  
Pressure - 1.0625 - 12 SAE O-Ring  
**AB** – Side Port  
Suction - 1.625 - 12 SAE O-Ring  
Pressure - 1.0625 - 12 SAE O-Ring  
**AC** – Rear Port  
Suction - M42 X 2 Metric O-Ring  
Pressure - M27 X 2 Metric O-Ring  
**AD** – Side Port  
Suction - M42 X 2 Metric O-Ring  
Pressure - M27 X 2 Metric O-Ring

**AE** – Rear Port  
Suction - 1.25" (Code 61) with .4375 - 14 UNC - 2B Threads  
Pressure - .75" (Code 61) with .375 - 16 UNC - 2B Threads

**AF** – Side Port  
Suction - 1.25" (Code 61) with .4375 - 14 UNC - 2B Threads  
Pressure - .75" (Code 61) with .375 - 16 UNC - 2B Threads

**AG** – Rear Ports  
Suction - M48 Metric O-Ring; Pressure - M33 Metric O-Ring

### 12 Case Drain Ports

**A** – .875 - 14 SAE O-Ring - Top  
**B** – .875 - 14 SAE O-Ring - Bottom  
**C** – M22 X 1.5 Metric O-Ring - Top  
**D** – M22 X 1.5 Metric O-Ring - Bottom  
**G** – .75 - 16 SAE O-Ring - Vertical  
**H** – M18 X 1.5 Metric O-Ring - Vertical

### 13 Diagnostic Pressure Ports

**1** – .4375 - 20 SAE O-Ring Port - Plugged  
**2** – M12 X 1.5 Metric O-Ring Port - Plugged

### 14 Controller Type

**A** – Pressure Flow Compensator With .4375 - 20 SAE O-Ring Load Sense Port#  
**B** – Pressure Flow Compensator With M12 X 1.5 Metric O-Ring Load Sense Port  
**C** – Pressure Compensator Only  
**V** – EH Inverse Proportional Pressure Control (vertical mounting)

**W** – Remote Pressure Control with .4375-20 SAE O-Ring Port, Left Side#  
**1** – Remote Pressure Control M12 Metric O-Ring Port, Left Side

### 15 16 Pressure Compensator Setting (Tolerance on Setting)\*

**02** – 76 - 83 bar (1100-1200 lbf/in<sup>2</sup>)  
**26** – 197 - 203 bar (2850-2950 lbf/in<sup>2</sup>)  
**34** – 234 - 241 bar (3400-3500 lbf/in<sup>2</sup>)  
**43** – 276 - 283 bar (4000-4100 lbf/in<sup>2</sup>)

### 17 18 Flow Compensator / Remote Pressure Control Setting (Tolerance on Setting)

**00** – No Flow Compensator Setting  
**14** – 12 - 15 bar (180-220 lbf/in<sup>2</sup>)  
**20** – 17 - 20 bar (250-290 lbf/in<sup>2</sup>)

### 19 20 Torque Control Setting

**00** – No Torque Control

### 21 22 Control Special Features

**00** – No Control Special Features  
**0A** – Bleed Down Orifice  
**0B** – 24V Cold Start Valve  
**0S** – 12V DC Solenoid AMP Jr Connector (used with EH inverse proportional pressure control)  
**0T** – 24V DC Solenoid AMP Jr Connector (used with EH inverse proportional pressure control)  
**0U** – 12V DC Solenoid Deutsch Connector (used with EH inverse proportional pressure control)

**0V** – 24V DC Solenoid Deutsch Connector (used with EH inverse proportional pressure control)

### 23 Maximum Displacement Option\*

**1** – Standard Displacement (As Given in Code Title)  
**2** – External Manual Stroke Adjustment

### 24 25 Auxiliary (Rear) Mount & Output Shaft

**00** – No Auxiliary Mounting Features  
**AA** – SAE A -2 Bolt, 9T 16/32 Spline  
**AB** – SAE A- 2 Bolt, 11T 16/32 Spline  
**AC** – SAE B- 2 Bolt, 13T 16/32 Spline  
**AG** – Auxiliary Mount Ready with Cover Plate

### 26 Shaft Seal

**1** – Standard Viton® Shaft Seal  
**2** – Nitrile Shaft Seal

### 27 28 Pump Special Features

**00** – No Special Features  
**AB** – Swash Position Sensor

### 29 30 Paint

**00** – No Paint  
**0B** – Black  
**CD** – Blue Primer

### 31 Identification/Packaging

**1** – Standard Eaton Identification Box Packaging

### 32 Design Level

**A** – First Design

\* Additional Settings Available by Request, including fixed displacement stops.  
# - Recommend RPC pressure settings 10-21 bar (140-350 psi)

# Specifications and Performance

## General Performance Specifications

		Units	AEC028
<b>Displacement</b>		cc/r (in <sup>3</sup> /r)	28.0 (1.71)
<b>Weight<sup>1</sup></b>		kg (lbm)	16.3 (35.9)
<b>Pressure</b>	Continuous	bar (psi)	280 (4060)
	Intermittent <sup>2</sup>		320 (4600)
	Peak <sup>3</sup>		350 (5000)
<b>Speed<sup>4</sup></b>	At 1 bar abs (0 psig)	rpm	3000
	At .85 bar abs (5 in.Hg)		2700
	Max (standby)		3600
	Min		500
<b>Power</b>	Max (theoretical)	kW (hp)	39.2 (52.6)
	Standby		2.1 (2.8)
<b>Torque</b>	Max (theoretical)	Nm (lb-ft)	125 (92)
<b>Bearing Life<sup>5</sup></b>	At 140 bar (2030 psi)	B10 Hours	62,000
	At 210 bar (3045 psi)		16,000
	At 280 bar (4060 psi)		5,850
<b>Mass Moment of Inertia</b>		Kg-m <sup>2</sup> (lbm-ft <sup>2</sup> )	0.005 (0.119)

1 Standard SAE B non-through drive.

2 Less than 10% of duty cycle.

3 Momentary system pressure spikes only.

4 Ratings based on Flange ports.

5 Bearing life ratings at rated speed – 1 bar abs (0 psig) inlet. Will vary based on thrust and side loads.

## Inlet Pressure, Case Pressure, and Operating Temperature Requirements

Inlet Pressure		Case Pressure			Operating Temperature			
Rated bar abs (psig)	Minimum bar abs (in. Hg)	Maximum bar abs (psig)	Maximum Continuous bar abs (psig)	Maximum Intermittent bar abs (psig)	Peak bar abs (psig)	Rated °C (°F)	Minimum Temperature °C (°F)	Maximum Intermittent °C (°F)
1.0 (0)	0.85 (5)	4.4 (50)	1.3 (5)	3.1 (30)	6.2 (75)	93 (200)	-25 (-13)	104 (220)

## Hydraulic Fluids

Fluid	Recommended Operating Viscosity Range cSt (SUS)	Maximum Continuous cSt (SUS)	Maximum Viscosity at Startup cSt (SUS)	Minimum Viscosity @ Max. Temperature of 93°C (200°F) cSt (SUS)	Minimum Intermittent cSt (SUS)
Use antiwear hydraulic oil, or automotive type crankcase oil (designations SC, SD, SE or SF) per SAE J183 FEB80	16 to 40 (80 to 188)	430 (1192)	2100 (9720)	10 (59)	6 (46)

For more information, see Eaton publication 579. For operation on other alternative or environmentally friendly fluids, please contact your Eaton Representative.

# Control Options

## Load Sense and Pressure Compensator

### Load Sense and Pressure Compensator Control

The pump will provide power matching of pump output to system load demand, maximizing efficiency and improving load metering characteristics of any directional control valve installed between the pump and the load.

Load sensing ensures that the pump always provides only the amount of flow needed by the load. At the same time, the pump operating pressure adjusts to the actual load pressure plus a pressure differential required for the control action. When the system is not demanding power, the load sense control will operate in an energy-saving stand-by mode.

Typically, the differential pressure is that between the pressure inlet and service port of a proportionally controlled directional valve, or a load sensing directional control valve. See the model code on page 4 for differential pressure settings for load sensing.

If the load pressure exceeds the system pressure setting, the pressure compensator de-strokes the pump. The load sensing line must be as short as possible and can also be used for remote control or unloading of the pump pressure. For remote control purposes, it is recommended that you contact your Eaton Representative for the correct configuration of the control.

**Warning:** When adjusting the pressure limiter, install a 0 to 350 bar (0 to 5000 psi) gage in the outlet gage

port and limit the pressure setting to the continuous rated pressure for the pump displacement shown on page 6. It is possible to adjust the pressure compensator beyond the rated pressure of the pump. Doing so, may void the warranty of the X20 pump.

### Pressure Compensator Spring Pressure Ranges:

60 bar (870 psi) to 144 bar (2089 psi)

144 bar (2089 psi) to 280 bar (4060 psi)

### Flow Compensator (Load Sense) Spring Pressure Range:

10.3 bar (150 psi) to 17.2 bar (250 psi)

17.2 bar (250 psi) to 31.0 bar (450 psi)

### Typical Operating Curve

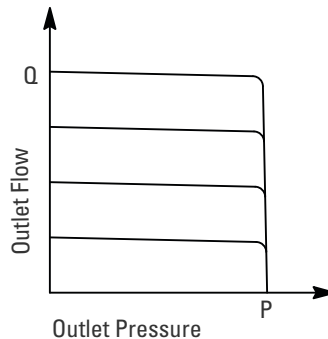

### Dynamic Response per SAE J745 (Using Swash Plate Position)

	Response (off stroke)	Recovery (on stroke)	Load Sense Recovery
	msec	msec	msec
AEC028	20	65	70

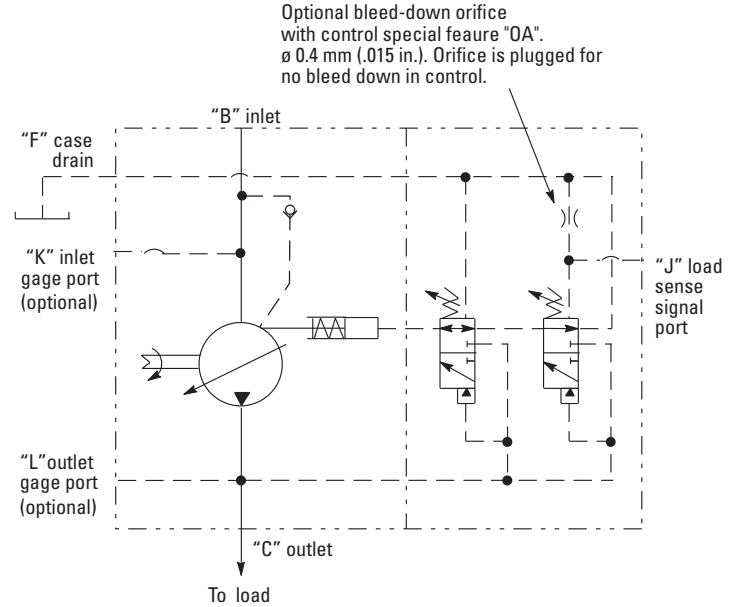

# Control Options

## Pressure Compensator

### Pressure Compensator Control

The pump will provide a continuously modulated flow to meet changing load demands at a pre-adjusted compensator pressure. At pressures below the compensator setting, the pump will operate at maximum displacement. See model code on page 4 for compensator pressure ranges.

**Warning:** When adjusting the pressure limiter, install a 0 to 350 bar (0 to 5000 psi) gage in the outlet gage port and limit the pressure setting to the continuous rated pressure for the pump displacement shown on page 6. It is possible to adjust the pressure compensator beyond the rated pressure of the pump. Doing so, may void the warranty of the X20 pump.

### Pressure Limit Settings

The pressure compensator uses two springs to cover the full pressure range of the X20 pumps. The high pressure spring covers the range from 140 bar (2050 psi) to 280 bar (4060 psi). The low pressure spring is adjustable from minimum pressure through 140 bar (2050 psi).

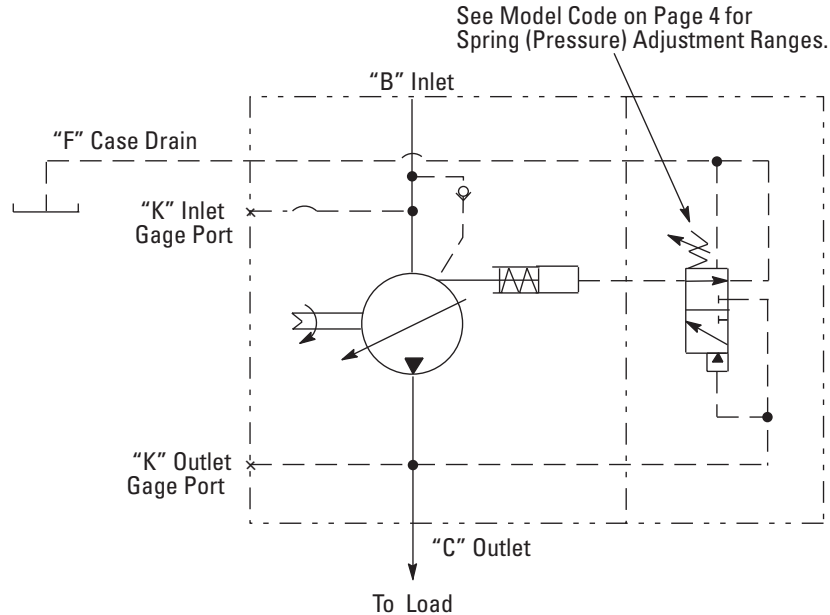

### Pressure Cut-off Characteristics of Pressure Compensator Control

@ 49°C (120°F),  
Static Conditions.

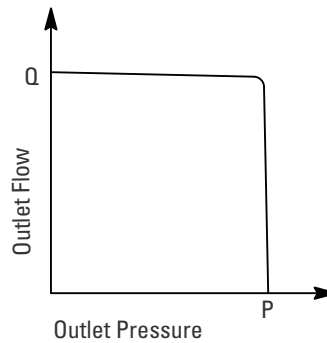

### Dynamic Response per SAE J745 (Using Swash Plate Position)

	Response (off stroke)	Recovery (on stroke)
	msec	msec
AEC028	20	65

# Control Options

## EH Inverse Proportional Pressure Control (IPPC)

### EH Inverse Proportional Pressure Control (IPPC)

The EH Inverse Proportional Pressure control allows for stepless variation of the max pump output pressure, as per the current signal provided to the control valve solenoid.

The integrated pump control makes use of an external current signal to vary the pump output pressure.

This control has an inverse proportional characteristic i.e. with increasing current signal, the max output pressure is proportionately reduced.

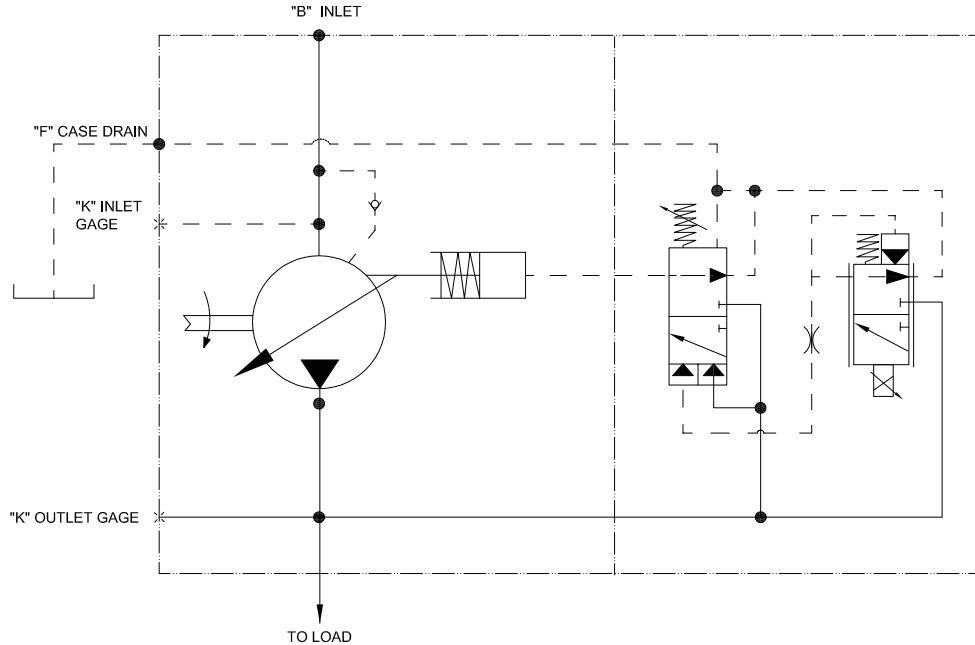

**Warning:** The pressure setting may be adjusted beyond the rated pressure of the pump. When adjusting the pressure, install a 0-350 bar (0-5000 psi) gage in the outlet gage port and limit the pressure setting to the continuous rated pressure for the pump displacement shown on page 6.

**Typ. Current vs Pressure Characteristics of IPPC at 1800 rpm at various max pressure settings at 49 deg C (120deg F), static conditions.**

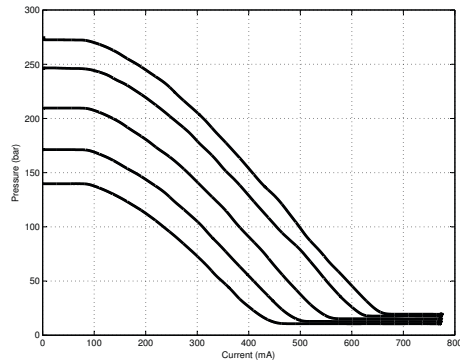

### Pressure Limit Settings

The EH IPPC covers pressure range of the ADU pumps. The max pressure can be set from 140 bar (2050 psi) to 280 bar (4060 psi).

### Electrical data

Voltage	12 V	24 V
Max Current	1500 mA	750 mA
R20, Resistance(ohm)	5.3 +/- 5%	21.2 +/- 5%
Type of Control	Current	Current
Recommended PWM Control Frequency	100 Hz	100 Hz
Duty Cycle	100%	100%
Insulation material	Class H, 180 deg C	Class H, 180 deg C
Protection Class	IP69K	IP69K
Connector	AMP Junior Power Timer/ Deutsch Connector DT04-2P	AMP Junior Power Timer/ Deutsch Connector DT04-2P
Operating Temperature	-30 deg C; 105 deg C	-30 deg C; 105 deg C

# Control Options

## Remote Pressure Control

### Remote Pressure Control

Remote relief valve is to be connected to pilot port "J" through necessary external piping. Standard differential pressure of 20 bar is set at RPC spool. The required outlet pressure (below 280 bar) can be set by adjusting remote relief valve setting. Once pressure reaches pre-set value, flow across remote relief valve starts, this results in RPC spool movement due to pressure imbalance. This will de-stroke the pump to maintain the set pressure.

Secondary pressure compensator is provided to limit the max pressure setting as a fail safe measure. The delta pressure is factory set which can not be changed. If the remote line is connected directly to tank, the flow compensator setting selected in the model code will be the minimum pressure setting.

**\* Flow Compensator is not available with RPC.**

**\* Flow Compensator/ Remote Pressure Control setting should be selected within range of 10-24 bar (140-350 psi).**

**\* Remote relief valve is not included in supply scope of the pump.**

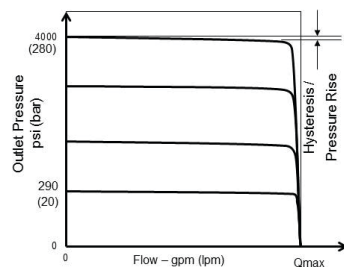
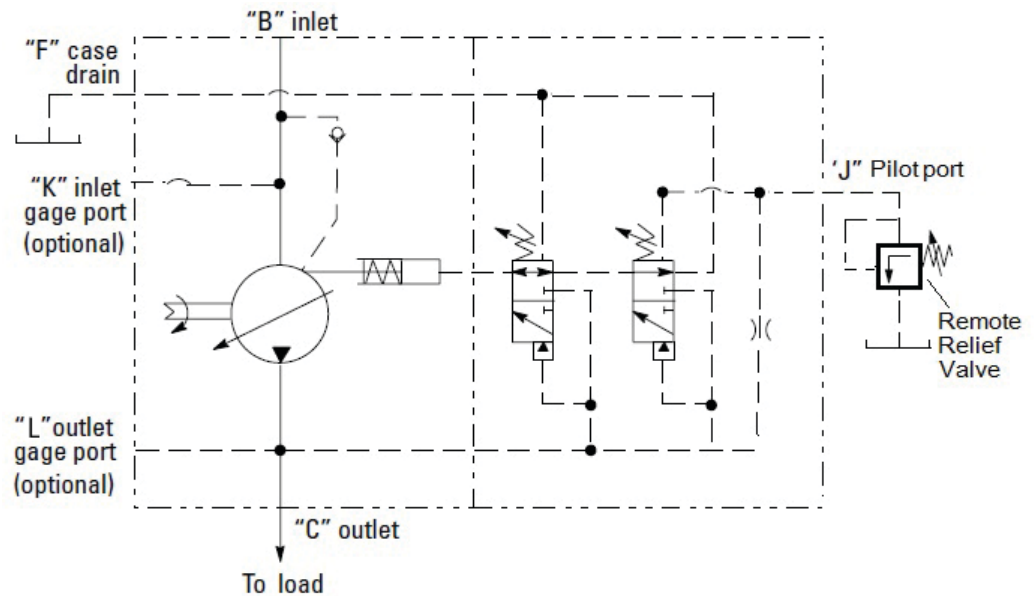

Delta Pressure setting at control valve - bar (psi)	14 - 24 (200 - 350)
Control fluid consumption - lpm (gpm)	4.5 (1.2) max.
Recommended flow rating of remote relief valve- lpm (gpm)	3 - 5 (0.8 - 1.32)
Recommended Eaton Relief Valve part number	RV5-10-S-0-50

# Performance

AEC028

**Overall Efficiency Versus Speed @ 49°C (120°F), Full Flow, and 1.0 bar (0 psi) Inlet**

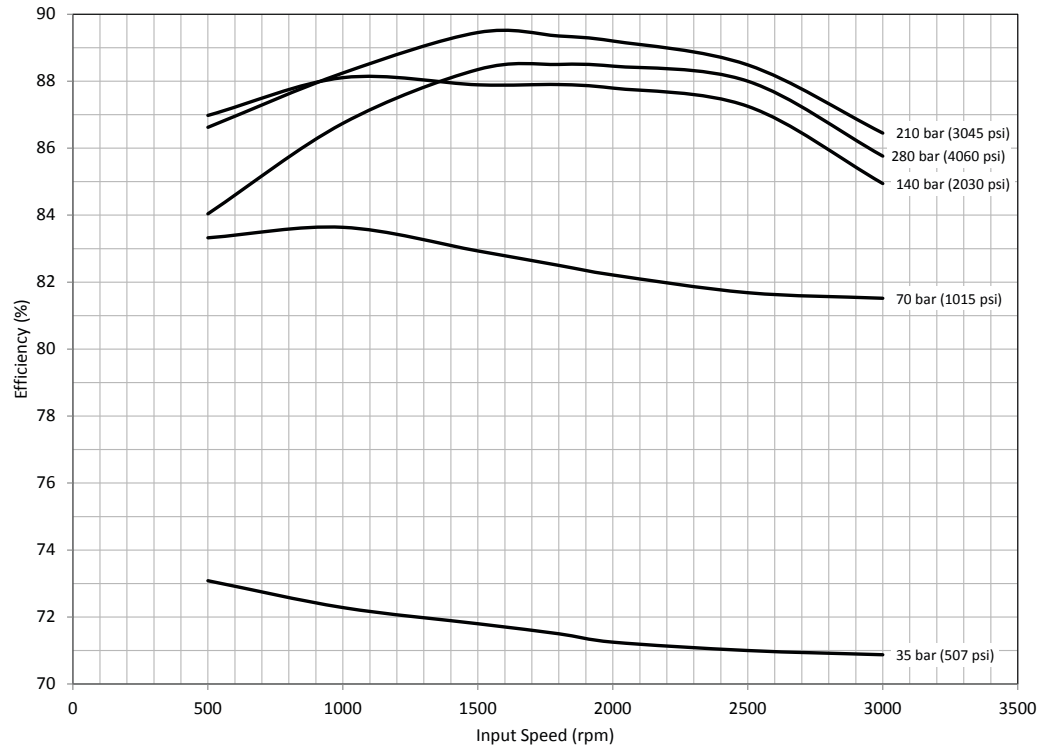

# Performance

AEC028

**Input Power Versus Speed @ 49°C (120°F), Full Flow, and 1.0 bar (0 psi) Inlet**

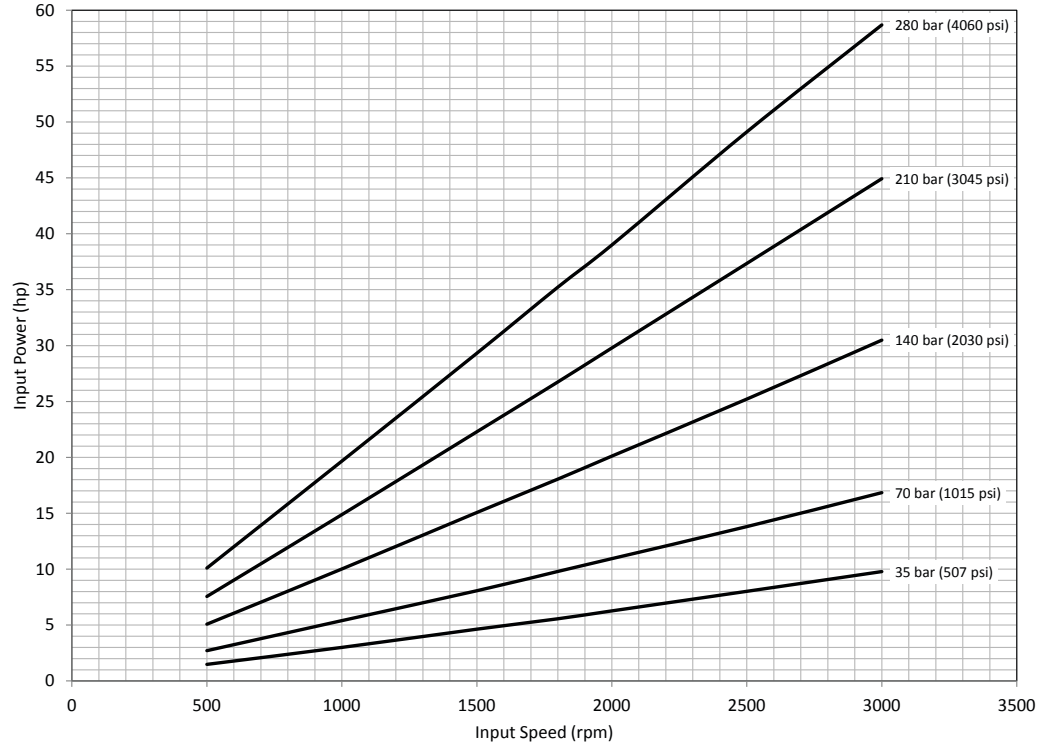

**Input Torque Versus Speed @ 49°C (120°F), Full Flow, and 1.0 bar (0 psi) Inlet**

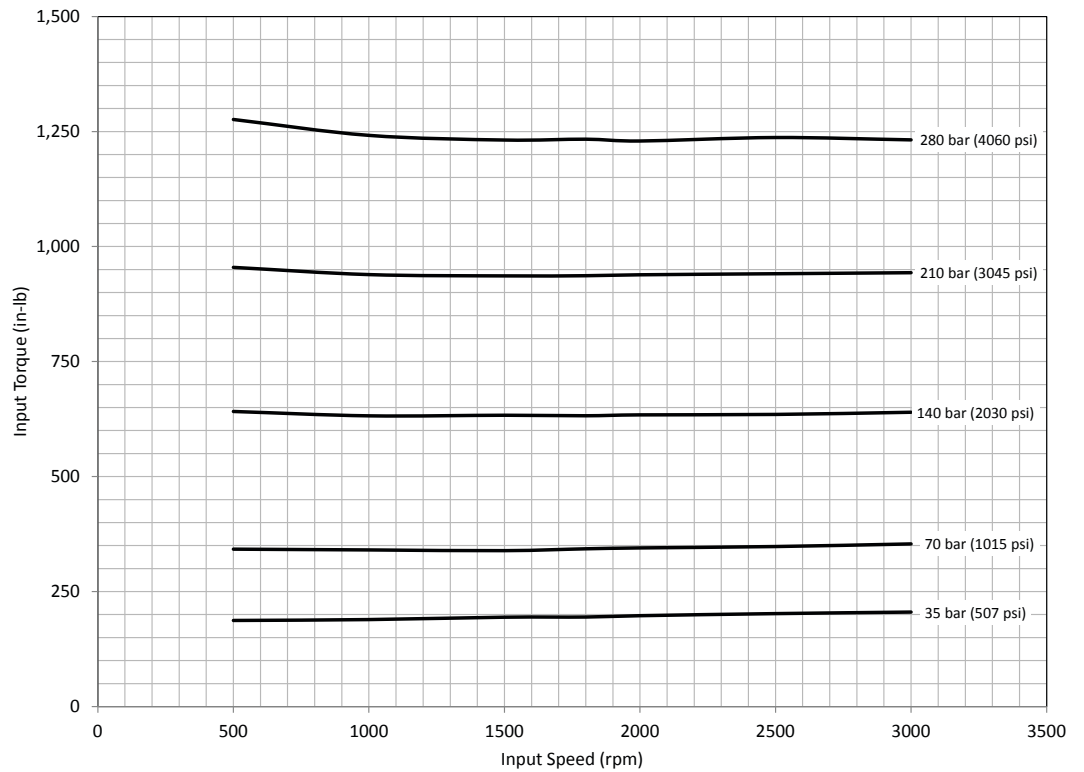

# Performance

AEC028

**Delivery and Case Flow  
Versus Speed @ 49°C (120°F)**

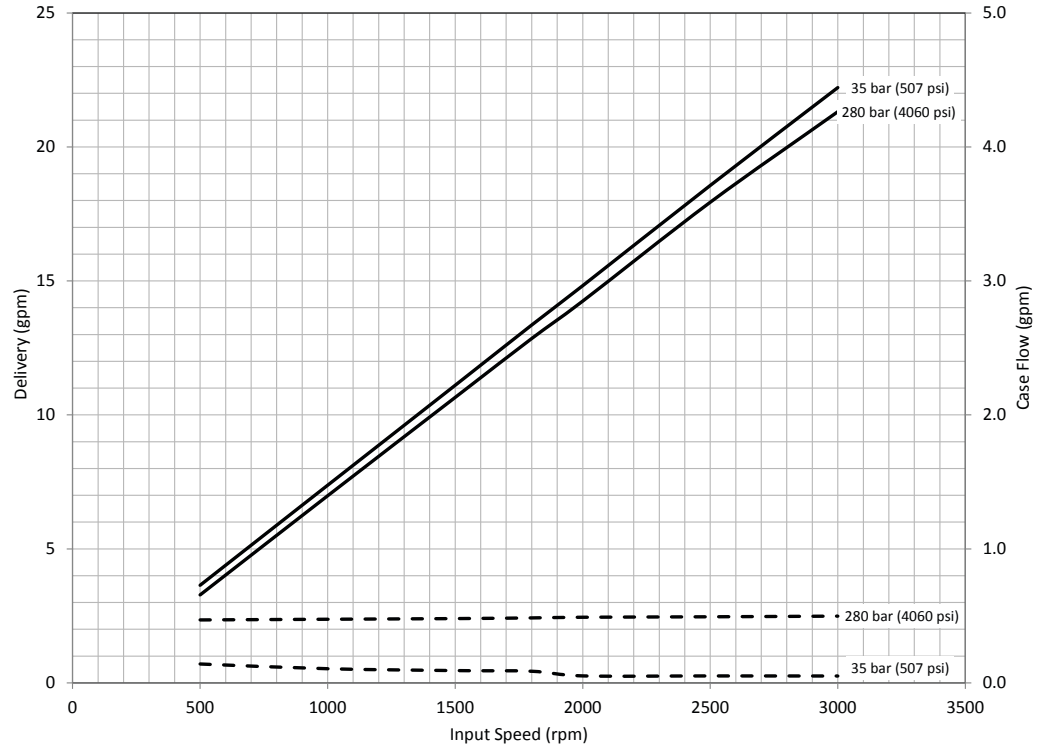

# Pump Installation

B-mount / Rear-ported

## RH Rotation

B-Mount / Rear Ported

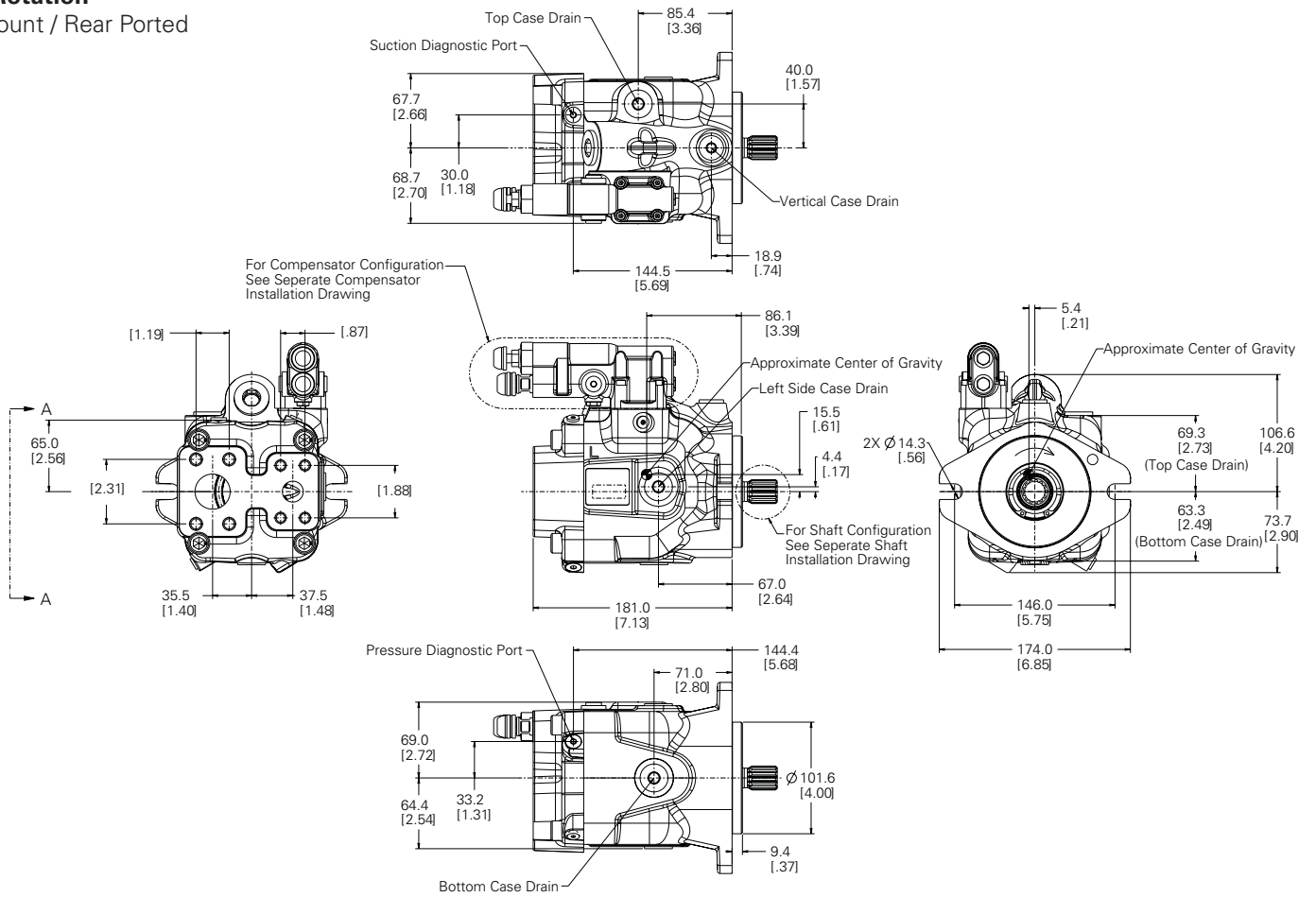

## View A-A

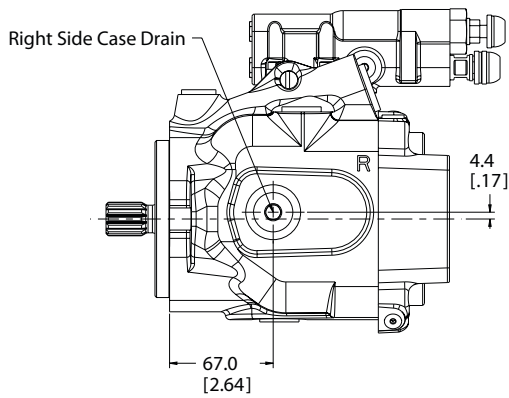

## LH Rotation

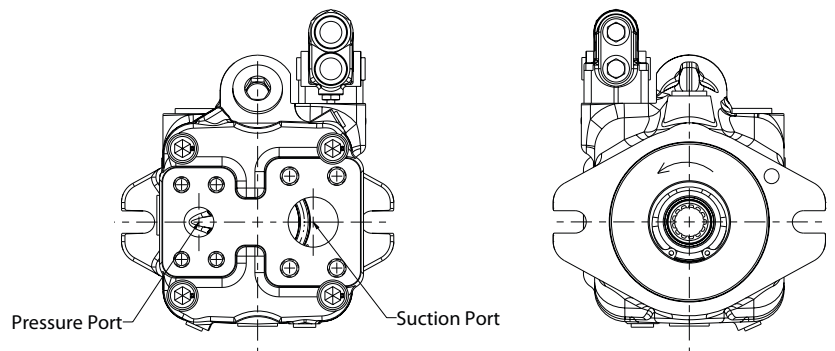

# Pump Installation

B-mount / Side-ported

## RH Rotation

B-Mount 2 Bolt/ Side Ported

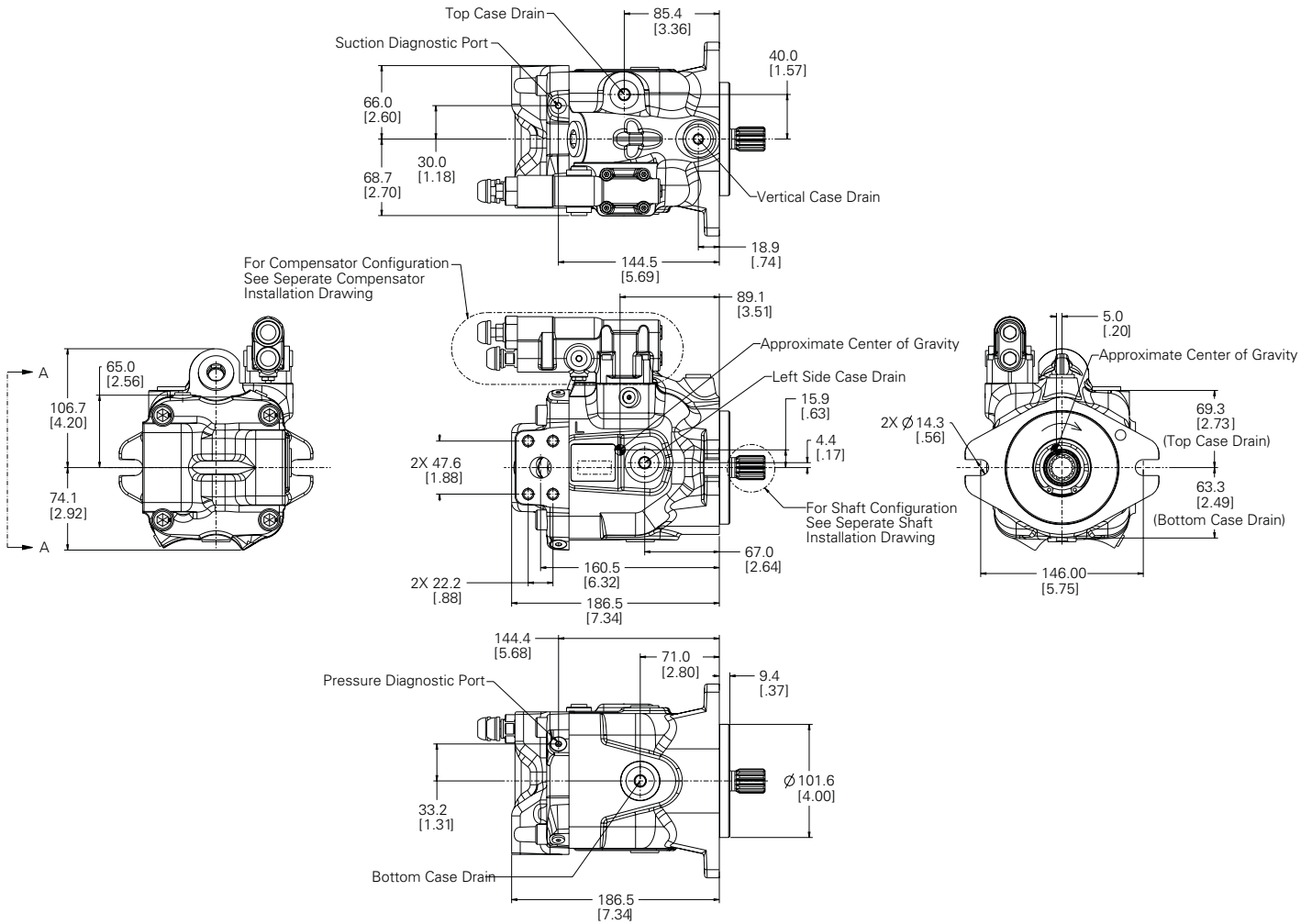

## View A-A

## LH Rotation

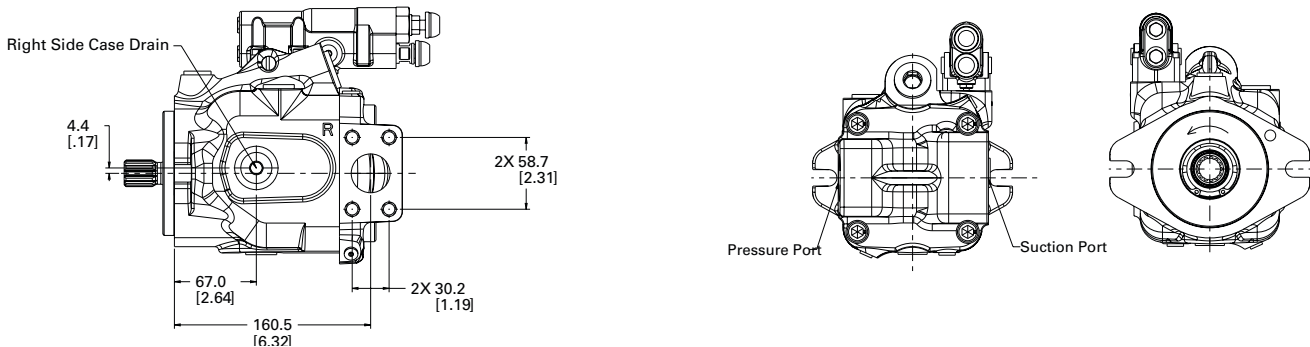

# Pump Installation

Thru-Drive SAE A

## SAE-A Mount

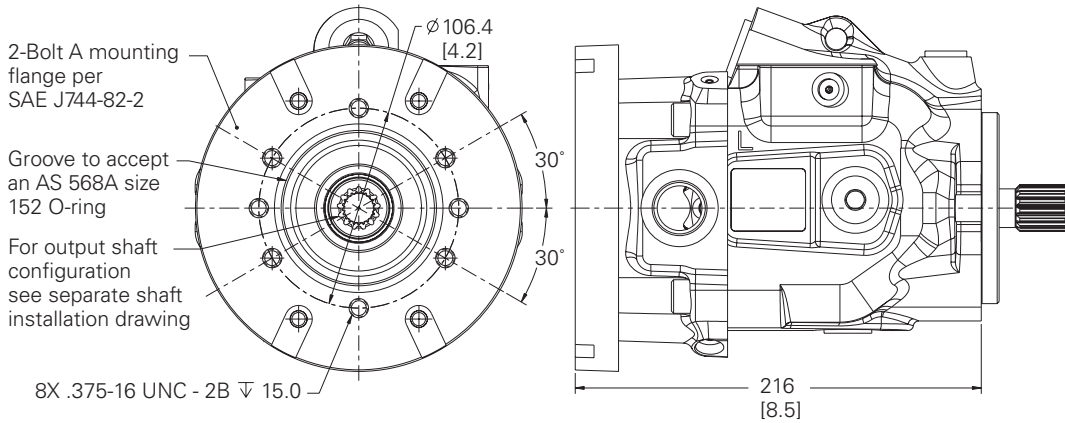

## Output Shaft Installation AA- 9T Spline

Max Torque 91 Nm (805 lbf-in)

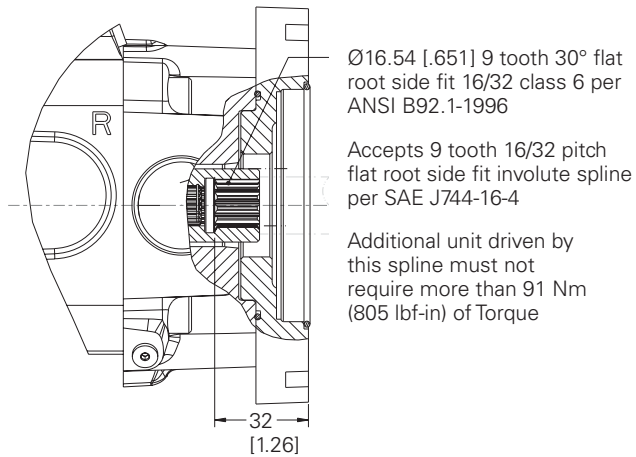

## Output Shaft Installation AB- 11T Spline

Max Torque 172 Nm (1522 lbf-in)

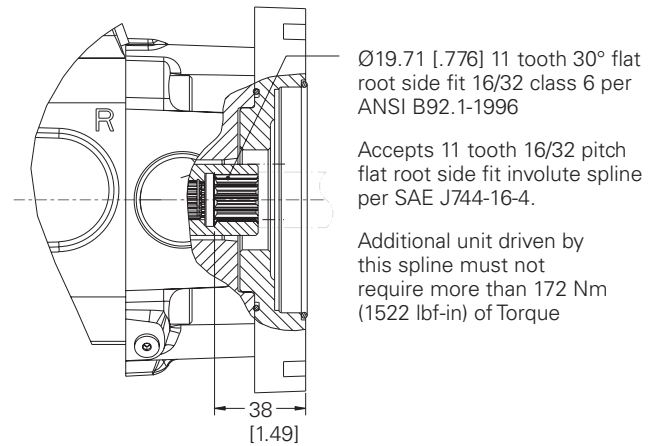

# Pump Installation

## Thru-Drive SAE B

### SAE B Pad Aux Mount

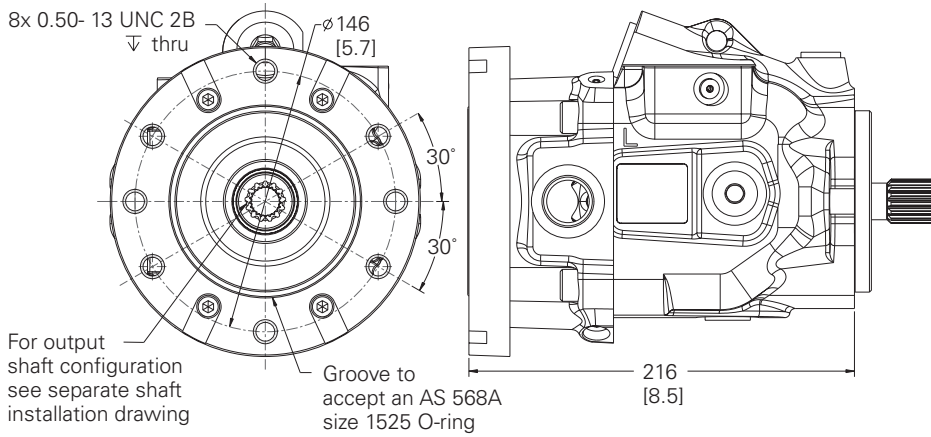

### AC - 13T Spline

Max Torque 252 Nm (2230 lbf-in)

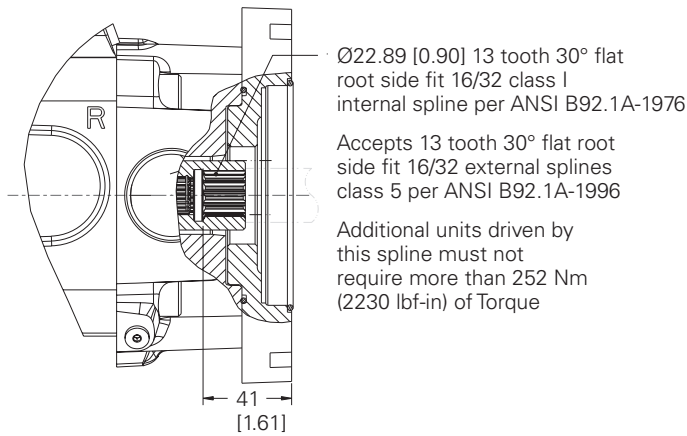

### Thru Drive Cover Plate Information

AG - Auxiliary mount ready with cover plate

### Cover Plate

Fits on 220-*SAE "A"* type auxiliary mounting end cover

Cover Plate Kit # 9901110-000; includes O-ring, Cover Plate, Cap Screws (2)

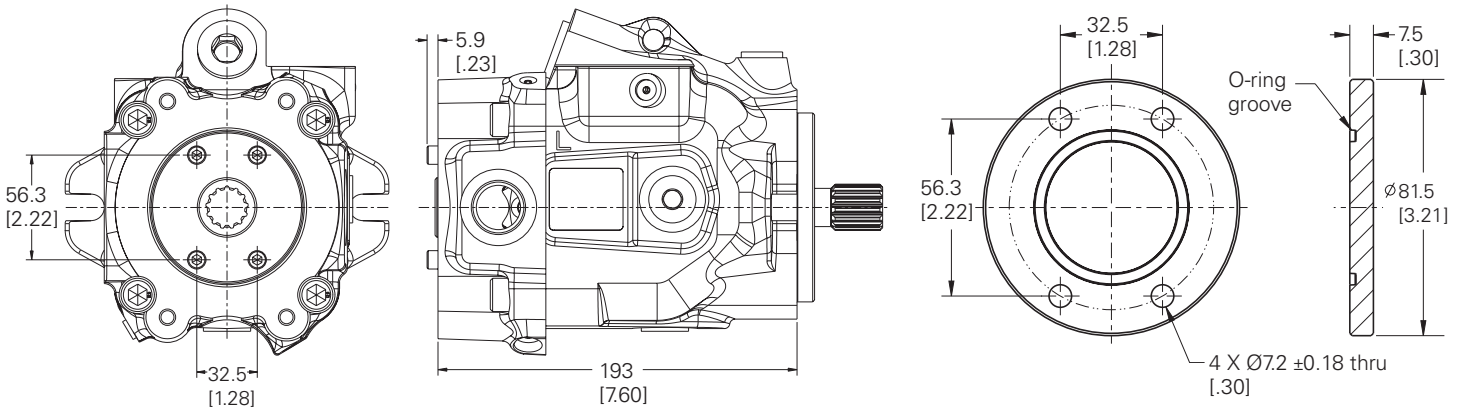

# Control Installation

## Load Sense and Pressure Compensator

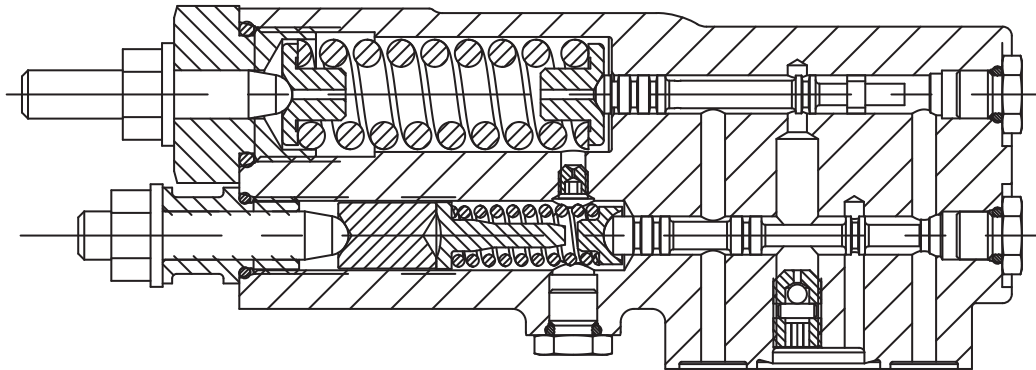
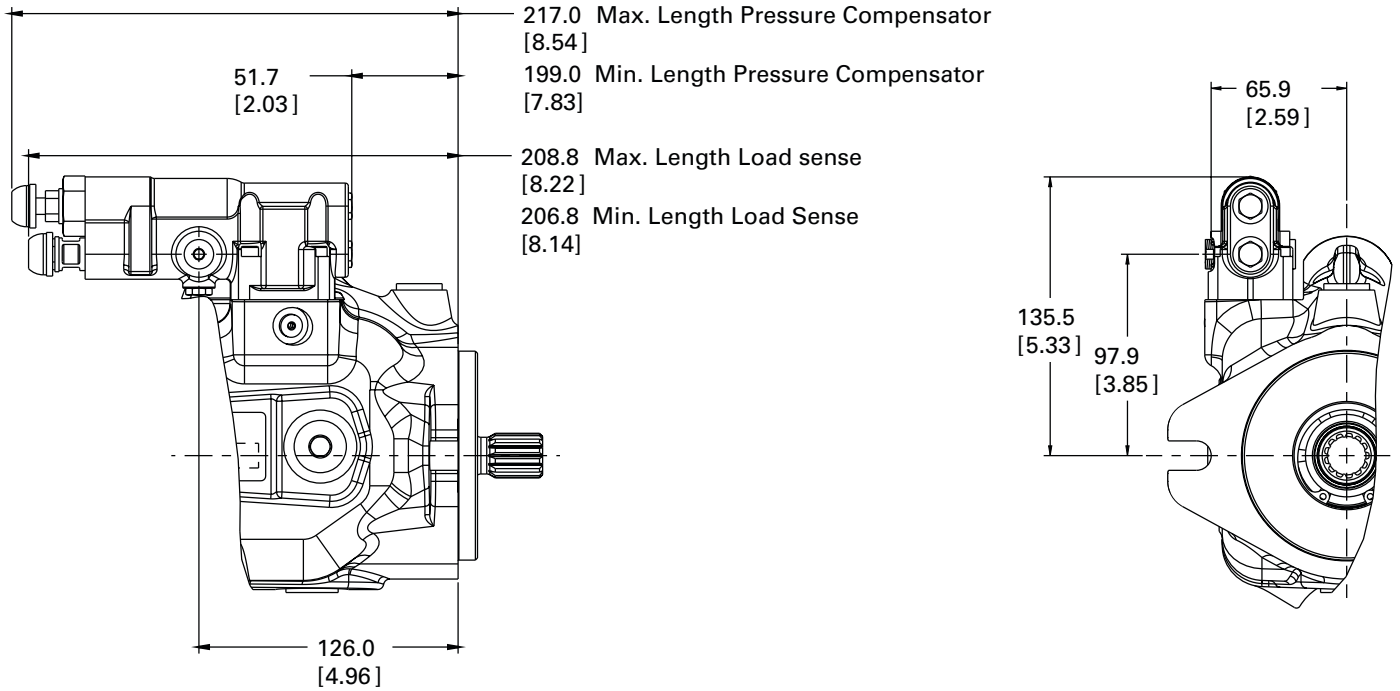

# Control Installation

## Pressure Compensator

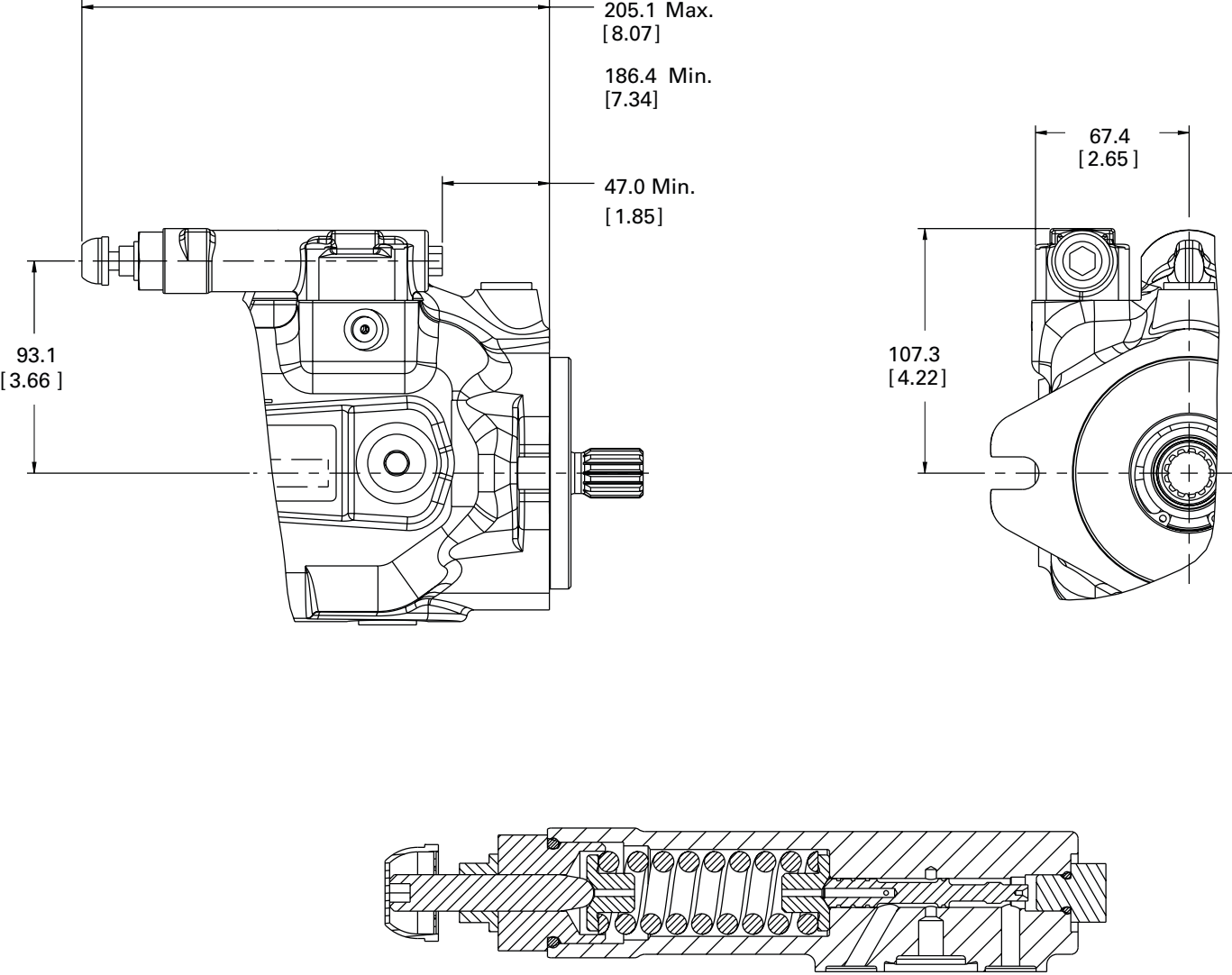

# Control Installation

EH Inverse Proportional Pressure Control (IPPC)

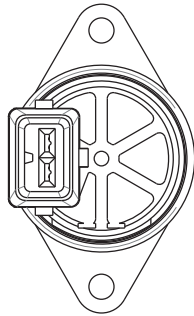
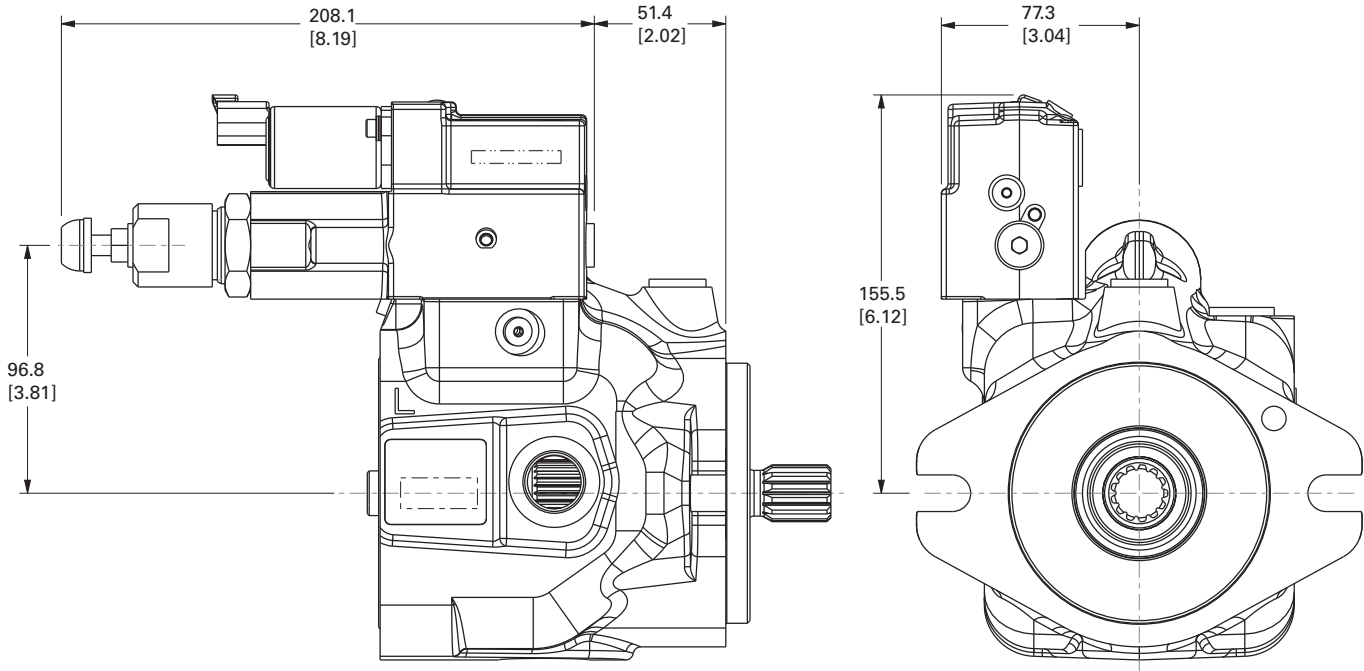

**AMP CONNECTOR OPTION**

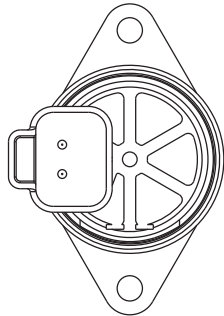

**DEUTSCH CONNECTOR OPTION**

# External Manual Stroke Adjustment

Maximum Stroke Limiter

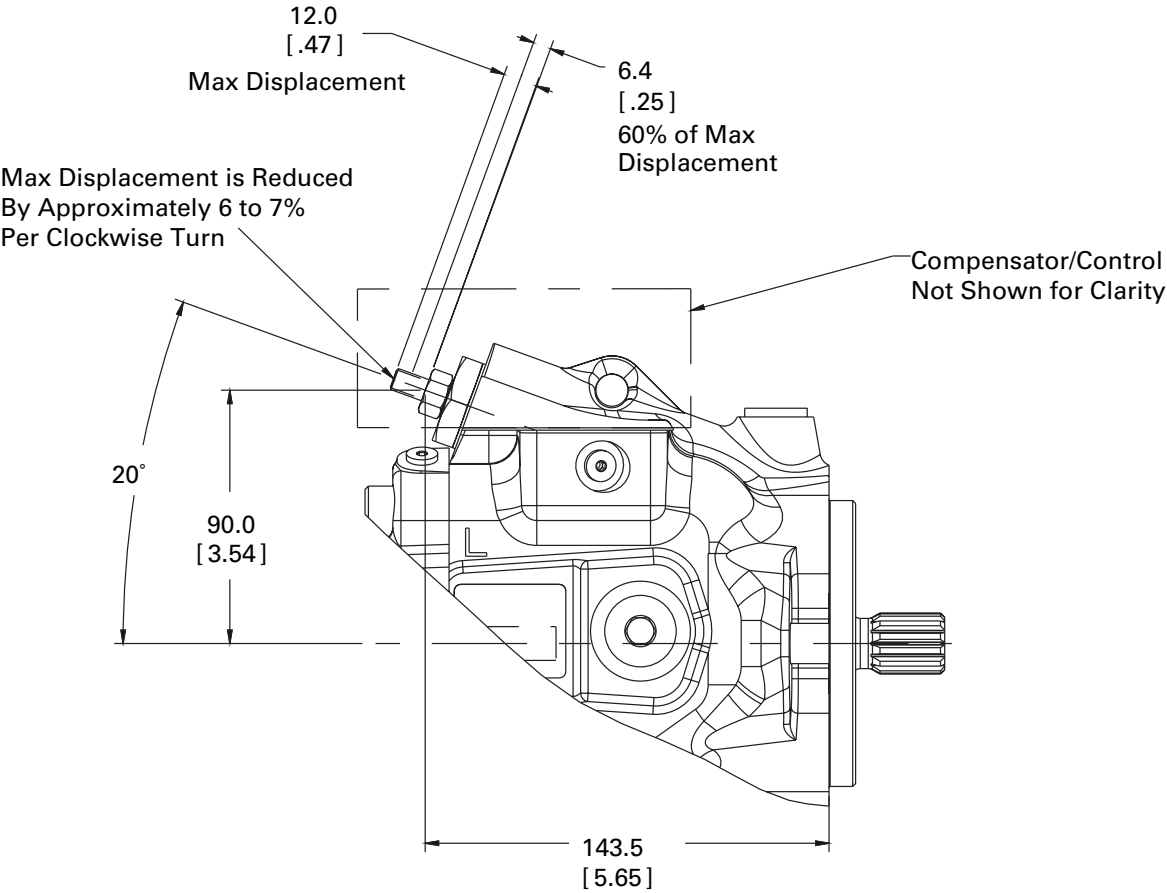

# Input Shaft Options

## 05 Code

Maximum Torque  
209.3 Nm [1852 in-lbf]

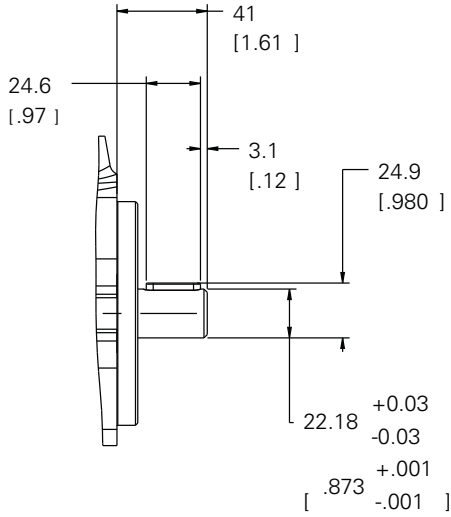
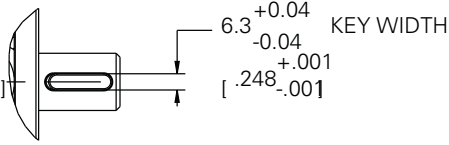

## 09 Code

Maximum Torque  
209.3 Nm [1852 in-lbf]

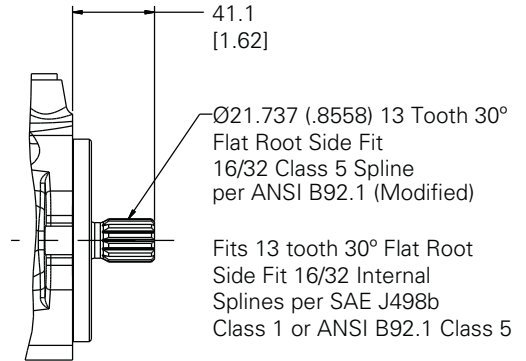

## 31 Code

Maximum Torque  
337.5 Nm [2987 in-lbf]

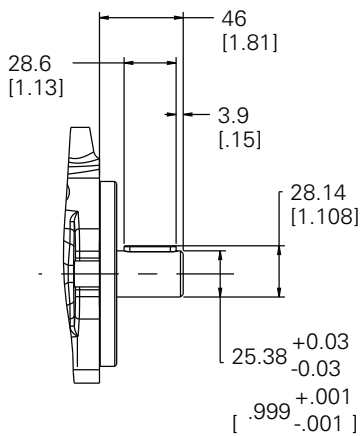
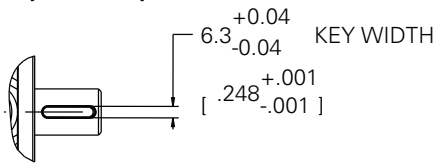

## 34 Code

Maximum Torque  
337.5 Nm [2987 in-lbf]

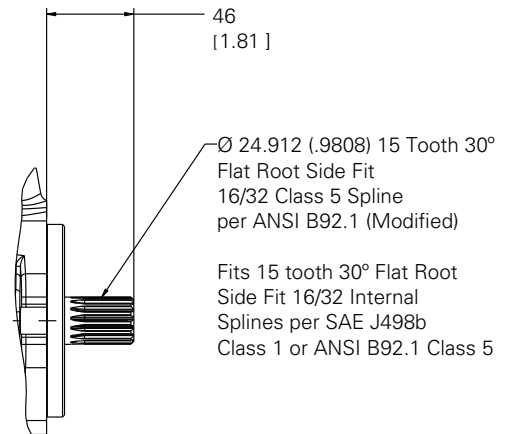

# Installation and Start-up

**Warning:** Care should be taken that mechanical and hydraulic resonances are avoided in the application of the pump. Such resonances can seriously compromise the life and/or safe operation of the pump.

## Drive Data

Mounting attitude should be horizontal (shaft parallel to the ground) using the appropriate case drain port (furthest from the ground) to ensure that the case remains full of fluid at all times. If mounted with shaft upward (shaft perpendicular to the ground) the shaft end case drain (option G or H) must be used.

## Fluid Cleanliness

The X20 Series pumps are rated in anti-wear petroleum fluids with a contamination level of 21/18/13 per ISO 4406. Operation in fluids with levels more contaminated than this is not recommended. Fluids other than petroleum, severe service cycles, or temperature extremes are cause for adjustment of these codes. Please contact your Eaton Representative for specific duty cycle recommendation.

Eaton X20 Series pumps, as with any variable displacement piston pumps, will operate with apparent satisfaction in fluids up to the rating specified here.

In those cases where geometric tolerances of mounting are critical, or where specific tolerance ranges are required and not specified, consult Eaton Engineering for specific limits.

Direction of shaft rotation, viewed from the prime mover end, must be as indicated in the model designation on the pump – either right hand (clockwise) or left hand (counterclockwise).

Direct coaxial drive through a flexible coupling is recommended. If drives imposing radial shaft loads are considered, please consult your Eaton Representative.

Experience has shown however, that pump and hydraulic system life is not optimized with high fluid contamination levels (high ISO cleanliness codes).

Proper fluid condition is essential for long and satisfactory life of hydraulic components and systems. Hydraulic fluid must have the correct balance of cleanliness, materials, and additives for protection against wear of components, elevated viscosity and inclusion of air.

Essential information on the correct methods for treating hydraulic fluid is included in Eaton publication 561 – “Eaton Guide to Systemic

## Start-up Procedure

Make sure the reservoir and circuit are clean and free of dirt/debris prior to filling with hydraulic fluid.

Fill the reservoir with filtered oil and fill to a level sufficient enough to prevent vortexing at the suction connection to pump inlet. It is good practice to clean the system by flushing and filtering, using an external slave pump.

**Caution:** Before the pump is started, fill the case through the uppermost drain port with hydraulic fluid of the type to be used. The case drain line must be connected directly to the reservoir and must terminate below the oil level.

Contamination Control” – available from your local Eaton distributor. In this publication, filtration and cleanliness levels for extending the life of axial piston pumps and other system components are listed. Included is an excellent discussion of the selection of products needed to control fluid condition.

Once the pump is started, it should prime within a few seconds. If the pump does not prime, check to make sure that there are no restrictions between the reservoir and the inlet to the pump, and that the pump is being rotated in the proper direction, and that there are no air leaks in the inlet line and connections. Also check to make sure that trapped air can escape at the pump outlet.

After the pump is primed, tighten the loose outlet connections, then operate for five to ten minutes (unloaded) to remove all trapped air from the circuit.

If the reservoir has a sight gage, make sure the fluid is clear – not milky.



Eaton  
Hydraulics Group USA  
14615 Lone Oak Road  
Eden Prairie, MN 55344  
USA  
Tel: 952-937-9800  
Fax: 952-294-7722  
[www.eaton.com/hydraulics](http://www.eaton.com/hydraulics)

Eaton  
Hydraulics Group Europe  
Route de la Longeraie 7  
1110 Morges  
Switzerland  
Tel: +41 (0) 21 811 4600  
Fax: +41 (0) 21 811 4601

Eaton  
Hydraulics Group Asia Pacific  
Eaton Building  
No.7 Lane 280 Linhong Road  
Changning District, Shanghai  
200335 China  
Tel: (+86 21) 5200 0099  
Fax: (+86 21) 2230 7240