



*Powering Business Worldwide*

# Table of Contents

Markets, Applications, and Equipment . . . . .	3
How STC Works . . . . .	4
Understanding STC Components . . . . .	5
How to Order STC Connectors . . . . .	6
Performance Characteristics . . . . .	7
STC Test Regimen . . . . .	8
What You Should Know About STC Connectors . . . . .	9
Installation and Disconnection of STC Connection . . . . .	10
Service Instructions for STC Connectors . . . . .	11
Assembly Method and Verification . . . . .	12
STC Insertion Length and Connection Dimensions . . . . .	13
Global Crimp Hose Nipples . . . . .	14
TTC Crimp Fittings . . . . .	17
TTC12 Crimp Fittings . . . . .	18
Crimp Nipples for FC699 Hose . . . . .	19
Crimp Nipples for Teflon® Hose . . . . .	20
OTC Crimp Fittings . . . . .	21
Crimp Fittings for SAE 100R5 Hose . . . . .	22
STC Socketless Fittings . . . . .	23
Female STC Cap and Male STC Plug . . . . .	24
Brazed Male and Female STC on High Pressure Carbon Steel Tubing . . . . .	25
Braze-On Male and Female Spud for Tubes . . . . .	26
Formed Male STC Tubing (Carbon Steel) . . . . .	27
Adapters . . . . .	28
Press Fit Adapters . . . . .	39
Press Fit Adapter Installation Instructions . . . . .	41
Direct Port STC Connections . . . . .	42
Female Ring Insertion Tools . . . . .	44
Accessories and Sales Tools . . . . .	48

\* Teflon is a registered trademark of DuPont used under license by Eaton.

***Eaton Hydraulics warranty policy is located at [www.eaton.com/hydraulics/warranty](http://www.eaton.com/hydraulics/warranty)***

# Markets, Applications, and Equipment



## Applications

- Hydraulic
  - Power Steering
  - Auxiliary Hydraulics
  - Power Brakes
  - Turbochargers
  - Fuel Injection Systems
  - Hydraulic Work Circuits
- Air Conditioning, Refrigeration and Truck and Bus
  - Refrigerant Supply Lines
  - Compressor Discharge
  - Power Steering
  - Oil Cooler
- Pneumatic
  - Brakes
  - Air Supply Lines
- Cooling
  - Transmission Oil Coolers
  - Heat Exchangers

## Equipment

- Tractors
  - Ag and Utility
- Loaders
  - Backhoe and Skid-Steer
- Engines
  - Truck, Marine, Construction
- Snow plows
- Trucks
  - Lift, Utility Bucket
- Crawlers
- Compressors
- Trailers
- Reel and Deck Mowers
- Asphalt and Concrete Pavers
- Trenchers
- Lift Platforms
- Hydraulic Attachments

# How STC Works

## STC Assembly Action

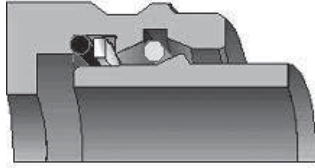

The male connector is inserted into the female connector. The male shoulder spreads the latch ring open.

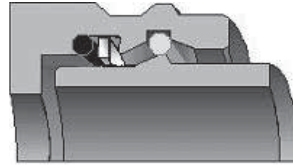

When the latch ring is in its open position, the male shoulder can slide past the latch ring.

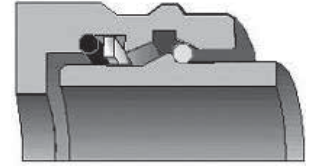

The male and female are locked into place. As fluid pressure is applied, the latch ring is wedged between the male shoulder and the female angle.

**Note:**

*Always remember to verify that your STC connection has been made successfully by pulling on the connection.*

## STC Disassembly Action

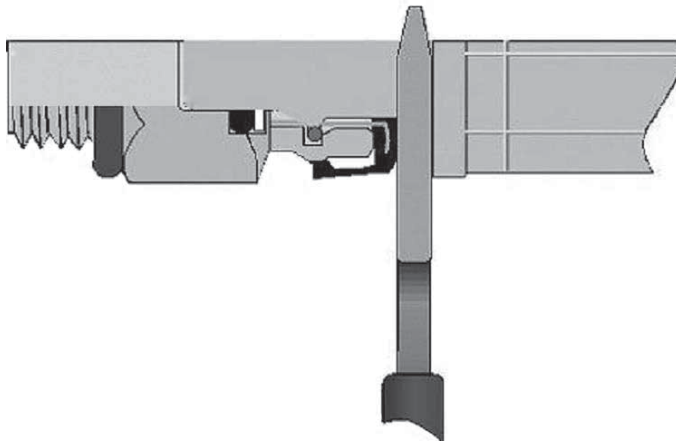

As the STC tool is inserted behind the release sleeve, the steel insert pushes the latching ring forward into a groove in the female half I.D., allowing the two halves to be pulled apart. The thickness of the tool moves the sleeve forward far enough to make the disconnection, so prying sideways with the tool is unnecessary.

**Note:**

Do not use the disconnect tool to pry on the parts. Prying can result in damage. Insert the tool straight into the connection.

The proper connection and disconnection of STC parts is outlined in on page 12.

**⚠ Warning:**

*Do NOT disconnect STC connection when under pressure. Failure to observe the foregoing may result in property damage or personal injury.*

# Understanding STC Components

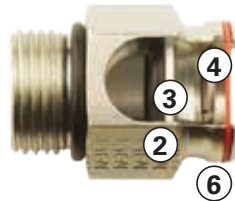

Female STC Connector



Male STC Connector

## 1. Disconnecting Tool

Used for disconnecting the two halves of an STC connection.

## 2. O-Ring\*

Buna-N (standard), fluorocarbon, EPR, or HNBR materials provide leak-proof sealing for hydraulic, air, and refrigeration applications.

## 3. Back-Up Ring\*\*

PTFE back-up ring provides resistance to high pressure o-ring extrusion under critical impulsing applications.

## 4. Latch Ring

Stainless steel latch ring connects the two halves while under full pressure, impulsing applications.

## 5. Latch Ring

A steel insert molded to an elastomeric dustboot provides both the mechanism for disconnecting the mating STC halves and protection against contamination when the two halves are connected.

## 6. Latch Verification Ring

The male release sleeve covers the red o-ring on the female when the male and the female halves are properly connected.

\* -04 size only available with polyurethane seal material

\*\* -04 size does not include a back-up ring

# How to Order STC Connectors

## STC Adapters:

First, state the base part number, thread size, then the nominal STC interface size.

(For adapters add a "0" prefix to interface and port thread sizes 6 and 8.)

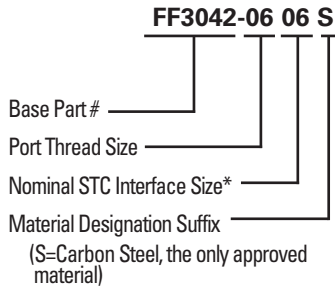

List o-ring material designation suffix; omit the "S" suffix if ordering alternate o-ring materials.

Buna-N (nitrile) is the STC standard; no suffix is needed for standard Buna-N.

EPR (Ethylene Propylene Rubber) = -212

Fluoroelastomer = -213

Neoprene = -352

HNBR = -461

Polyurethane = -523

Example: **FF3042-0606-213**

## STC Global Hose Crimp Hose Nipples:

Part numbers collapse to the shortest possible number of digits. It is assumed that a global fitting has a straight configuration unless a code is added to designate otherwise.

(Steel is the only available material.)

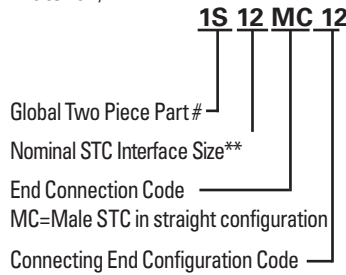

A=45

B=90 Standard or Medium Drop

C=90 Long Drop

## Standard Crimp Hose Fittings:

Fittings are ordered as component parts. First, state the base part number, then the nominal STC interface size, then the hose size.

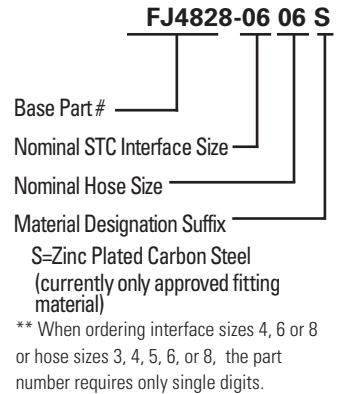

## Seal Elastomer Data

Seal Elastomer	Application Specification	Fluid Temperature Range
Buna-N/Nitrile	None	-40°F to +250°F (-40°C to +121°C)
EPR (Ethylene Propylene Rubber)	None	-65°F to +300°F (-55°C to +150°C)
Fluorocarbon	MIL-R-25897	-15°F to +400°F (-25°C to +205°C)
Neoprene	None	-65°F to +300°F (-55°C to +150°C)
HNBR (Hydrogenated Nitrile Rubber)	None	-40°F to +300°F (-40°C to +150°C)
Polyurethane*		-40°F to +250°F (-40°C to +121°C)

**Note:** Ambient temperature range is -40°F to +300°F (-40°C to +150°C).

\* For -04 STC only. STC size -04 comes standard with Buna-N (nitrile) o-ring on port connector ends.

# Performance Characteristics

## Design Features

- Positive round-wire style latching mechanism
- Swivels for installation (in absence of pressure)
- Low profile; compact design
- Elastomeric o-ring seal – available in many materials
- Capable of direct porting into valve blocks or manifolds
- Dual purpose dust seal/release sleeve
- Simple stamped release tool for disconnecting

## Benefits

- Fast reliable one-hand connections requiring no assembly tools
- Eliminates cross-threading, over or undertorquing, and hose twisting
- Installs easily in confined areas
- Virtually zero leak performance per SAE J1176
- Direct porting eliminates adapters to maximize cost savings
- Resists external contamination
- Allows easy disconnection with release tool

## Operating Characteristics

Interface Size	Maximum Operating Pressure		Minimum Burst Pressure		Vacuum	
	psi	bar	psi	bar	in./hg.	mm./hg.
1/4"	6,000	414	24,000	1,656	28	711
3/8"	5,000	345	20,000	1,380	28	711
1/2"	4,250	295	17,000	1,175	28	711
5/8"	4,000	275	16,000	1,100	28	711
3/4"	4,000	275	16,000	1,100	28	711
1"	4,000	275	16,000	1,100	28	711

## Technology Comparison

	Threaded Fittings	STC Fittings
Assembly tools required	•	
Torque sensitive	•	
Limited reusability	•	
Virtually zero leakage		•
Fast, reliable connections		•
Ease of installation in confined areas improved ergonomics		•
Ease of orienting hose ends		•
Compact design, install and remove in limited access areas		•

## Product Qualification Testing

- One million cycle impulse test in excess of 133% of DIN2ST operating pressures with side load
  - Testing for fatigue of connection
  - Square wave fluid impulse with side load
  - Virtually zero leakage performance criteria per SAE J1176
- Burst pressures exceed 4 times DIN2ST operating pressures
  - Proves connection reliability at high pressures
- 28 Inches Hg Vacuum
  - Product tested at seal max. & min temperatures
  - Same product is then tested to twice the maximum operating pressure
  - Virtually zero leakage performance criteria per SAE J1176
- Exceeds 96 hour salt spray
  - Functional & corrosion resistance test
  - Per ASTM B117
- Connect/Disconnect (250 Times)
  - After 250 connects/disconnects, adapters leak tested at twice maximum operating pressure
  - Virtually zero leakage performance criteria per SAE J1176
  - Proves connection reliability and release sleeve integrity

## Additional Application Testing

- Vibration (5-500 Hz)
  - Tested full vibration range for connector wear
  - Testing capability simulates application
- Extreme temperature test (-40° to +300°F)
  - Covers full range of applications
- Dust box and seal integrity testing
  - 48 hr, 4G vibration test in presence of fine, airborne dust particles (U.S. Silica-co-sil #106)
  - Tested effectiveness of dust seal in a heavily contaminated environment
  - Release sleeve sealing performance tested with connection in three (3) positions (up, down, and sideways)

### **Note:**

Application tests are size and o-ring specific and all tests may not apply to every connection size and o-ring. Please contact Eaton for more information regarding qualification and application tests.

# What Should You Know About STC Connectors

1. The STC connection is not recommended for use in swivel applications. Rotation should be limited to assembly and disassembly when zero pressure is present.
2. The o-ring seal determines the temperature range and fluid compatibility of the STC connection except when exceeding the release sleeve operating temperature of 300°F.
3. Disconnection of the STC connection should be limited to situations where there is no pressure present.
4. Installation of the male STC connector must be made straight into the adapter and not at an angle. Misalignment during the connection results in a higher connect force.
5. If the release sleeve is damaged during the connection or disconnection of the STC connection, the male portion must be replaced – premature failure of the STC connection may result if the replacement is not made.
6. Do not use the rubber sleeve as leverage to push the male half into the female half of the STC connection.
7. Applications that involve vibration should be analyzed with the aid of Eaton prior to utilization.
8. After the STC connection is made, pull on the connection to make sure the male STC connector is properly inserted into the female STC connector.
9. The use of clamps is highly recommended for long hose assemblies that utilize STC connections; the clamp should be positioned close to the STC connection to prevent its rotation.
10. STC connection should not be used as a quick disconnect coupling.
11. Do not hold sleeve during assembly.



*For your own safety, do not hold the release sleeve during assembly.*

**⚠Warning:**  
Do **NOT** disconnect STC connection when under pressure. Failure to observe the foregoing may result in property damage or personal injury.

# Installation and Disconnection of STC Connection

## Installation/Connection

- Install the STC port connector into the mating port carefully. Follow recommended installation procedures for the applicable port fittings.
- Align the STC fitting on

the hose assembly with the STC connector, and push the hose fitting into the mating STC connector until you feel a solid stop.

- Verify that the STC connection has been made

successfully by pulling on the connection to make sure that the male connector has been properly inserted into the female connector. Be sure that the direction

of pull is parallel to the axis of the STC connection. A visual indication can be made after assembly or verifying that the red indication ring is not visible.

## Disconnection

- Remove pressure from the system before attempting to disconnect these fittings in order to avoid forceful ejection of the fitting, which could result in personal injury.
- Some fluid may still be in the system. Minimize fluid

loss by draining the fluid from system components prior to disconnection.

- Prior to disconnection, clean the area around the fittings with a clean cloth, Or using an airgun to blow dirt and debris from the release sleeve area.

- To help avoid release sleeve tearing, create an (for the release sleeve) insertion gap by moving the sleeve in the release direction. (Figure 1). This can be done either by hand or by using a single prong of the release tool.

- Insert the release tool behind the release sleeve (D) and pull the hose assembly out from the mating STC connector (leaving the release tool inserted will aid disassembly). Do not pry on the fitting with the release tool.

### **⚠ Warning:**

Eaton STC fittings are designed to be installed only in mating STC connectors. Contact Eaton for additional information.



Figure 1

# Service Instructions for STC Connectors

## Seal Replacement Instructions Inspection

- STC fittings are designed to be connected and disconnected repeatedly without replacing the O-Ring and Back-Up Ring, unless leakage or damage is observed.
- Inspect mating STC fittings to ensure they are in good condition, clean and free of contaminants, nicks, scratches, flatspots, etc.
- Check the Wire Latch Ring (C) to ensure that it is in proper position in the female STC connector prior to installation or reconnection.
- Check the O-Ring (A) to ensure it is not cut or otherwise damaged prior to installation or reconnection.
- Check the Back-Up Ring (B) to ensure it is not damaged. Verify that it is at the front of the O-Ring groove prior to reconnection the fitting.
- If any damage is detected on either of the O-Ring, Back-up Ring or Latch Ring, replace them by the following procedures below.
- Carefully remove O-Ring (A) and Back-Up Ring (B) with an O-Ring pick with out damaging the interior surfaces of the fitting.
- Inspect the interior surfaces and grooves of the fitting and ensure they are free of foreign material or nicks, scratches, dents, etc.
- If undamaged, clean the fitting and install Back-Up Ring (B) at the front of the O-Ring groove.
- Install the new O-Ring (A) in the groove behind the Back-Up Ring (B) and inspect to insure O-Ring and Back-Up ring are secure in the groove. Lubricate O-Ring with a lubricant which is compatible with the system fluid.
- If the Wire Latch Ring (C) is damaged, carefully remove the Latch Ring without damaging the interior surfaces of the connector.
- Carefully insert the Wire Latch Ring in the Latch Ring groove. The new Wire Latch Ring should be able to rotate in the groove.
- Inspect and reinstall the connector. Follow the installation/connection steps for reinstallation.

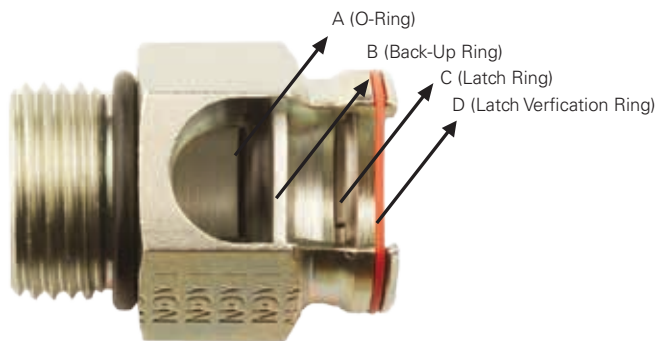

Figure 2. Female Post Connector

### ⚠ Caution:

Inspect to verify proper location of O-Ring and Back-Up Ring connector. (Refer to Figure 2) leakage could occur if installed incorrectly.

### ⚠ Caution:

If leakage is observed, and the fittings are in otherwise good condition, a seal placement kit must be installed or the fitting must be replaced. If seals are not replaced, a decrease in the system performance or damage to the system components may result.

### ⚠ Caution:

Any damaged O-Ring must be replaced with a new O-Ring and Back-Up Ring using only genuine Eaton parts. Any damaged fitting must be replaced with a new part to avoid leakage.

# Assembly Method and Verification

Align the STC fitting on the hose assembly with the STC connector. Push the hose fitting into the mating connector until you feel a definite snap and a solid stop.



**Correct Method**



**Incorrect Method**

Do not hold sleeve during assembly

Verify that the STC connection has been made successfully by pulling on the connection to make sure that the male connector has been properly inserted into female connector. Be sure that the direction of pull is parallel to the axis of the STC connection.

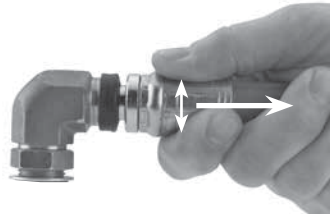

**Correct Method**

Pulling parallel to the connections axis



**Incorrect Method**

Pulling at an angle to connections axis



**Correct Method**

Pulling on the fitting such that the motion is parallel to the connections axis.

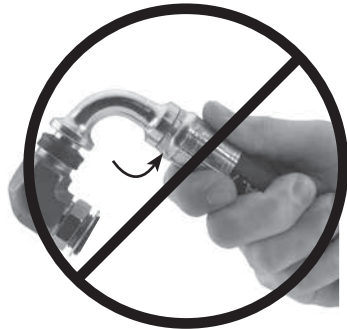

**Incorrect Method**

Subjecting the connection to a sideload by pulling on the hose.

# STC Insertion Length and Connection Dimensions

## Insertion Length/Length Loss

The insertion length is the length measured from the end of the inserted male STC nose to the outside face of the female STC half. This is the length of the STC male half that is inside of the female half after it is inserted. This insertion length (or length loss) should be taken into account when determining overall product assembly lengths.

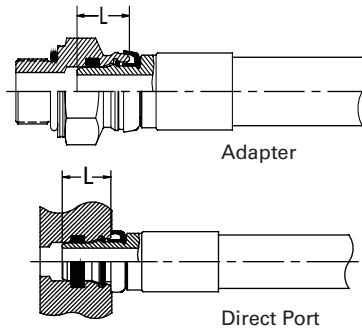

Dash Size	Avg Insertion Length/ Length Loss of STC w/Adapters	Avg Insertion Length/ Length Loss of STC Direct Port
	mm (in.)	mm (in.)
-04	12.8 (0.50)	-
-06	13.9 (0.55)	13.9 (0.55)
-08	18.4 (0.73)	18.4 (0.73)
-10	21.1 (0.83)	20.8 (0.82)
-12	25.4 (1.00)	25.1 (0.99)
-16	30.2 (1.19)	30.2 (1.19)

## Engagement Length/Connection Dimension

The engagement length is measured on a connected STC assembly and extends from the face (or end) of the STC female half to the face of the hex/round stock behind the release sleeve on the male half.

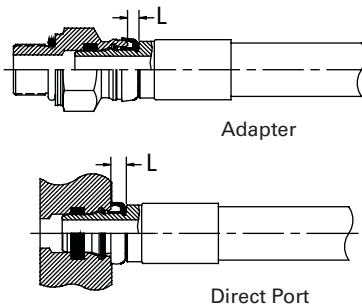

Dash Size	Engagement Length/ Connection Dimension of STC w/Adapters	Engagement Length/ Connection Dimension of STC Direct Port
	mm (in.)	mm (in.)
-04	3.9 (0.15)	-
-06	4.9 (0.19)	5.5 (0.22)
-08	5.3 (0.21)	6.4 (0.25)
-10	6.1 (0.24)	6.8 (0.27)
-12	6.1 (0.24)	6.8 (0.27)
-16	5.9 (0.23)	5.9 (0.23)

# Male Global Crimp Hose Nipples

For use with the following clamps and sockets:

Clamp: 2661 (-12 thru -16), FC619 (-12 thru -16)

Socket 1SA: 2681, FC310, FC510, FC639 (-4 thru -8), GH194, GH663, GH681

Socket 1SB: 1529, 2766, 2781, FC372 (-4 thru -16), FC373 (-4 thru -16), FC466, FC498, FC579, FC639 (-10 thru -16), FC735, FC839B, FC849, FC849B, GH120, GH195, GH683 (-4 thru -6), GH781, GH793

Straight Nipple Assembly  
1S\_MC\_

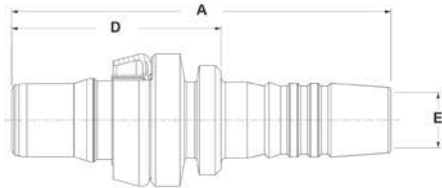

Straight Part No.	Dash Size	A	D	EØ
		mm (in.)	mm (in.)	mm (in.)
1S4MC4	-04	49,90 (1.97)	26,50 (1.04)	4,20 (0.17)
1S6MC4	-04	52,40 (2.06)	29,00 (1.14)	4,20 (0.17)
1S6MC6	-06	55,50 (2.19)	30,20 (1.19)	6,70 (0.26)
1S8MC6	-08	60,60 (2.39)	35,40 (1.39)	6,70 (0.26)
1S8MC8	-08	66,30 (2.61)	36,60 (1.44)	9,60 (0.38)
1S10MC8	-08	72,90 (2.87)	43,20 (1.70)	9,60 (0.38)
1S8MC10	-10	66,80 (2.63)	37,40 (1.47)	23,80 (0.94)
1S10MC10	-10	69,00 (2.72)	39,60 (1.56)	12,80 (0.50)
1S12MC12	-12	74,60 (2.94)	44,40 (1.75)	15,50 (0.61)
1S16MC16	-16	83,70 (3.30)	49,30 (1.94)	20,70 (0.82)

45° Nipple Assembly 1S\_MCA\_

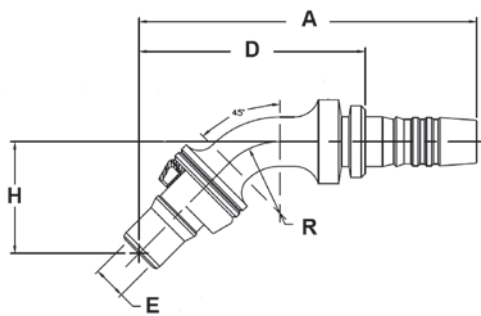

45° Part No.	Dash Size	A	D	H	EØ	R
		mm (in.)	mm (in.)	mm (in.)	mm (in.)	mm (in.)
1S4MCA4	-04	64,60 (2.54)	41,20 (1.62)	21,20 (0.83)	4,20 (0.17)	13,00 (0.51)
1S6MCA4	-04	69,80 (2.75)	46,40 (1.83)	22,20 (0.87)	4,20 (0.17)	14,00 (0.55)
1S6MCA6	-06	72,90 (2.87)	47,60 (1.87)	22,20 (0.87)	6,40 (0.25)	14,00 (0.55)
1S8MCA8	-08	89,90 (3.54)	60,20 (2.37)	29,60 (1.17)	8,80 (0.35)	19,00 (0.75)
1S10MCA8	-08	97,40 (3.83)	67,70 (2.67)	33,60 (1.32)	11,50 (0.45)	22,00 (0.87)
1S8MCA10	-10	89,90 (3.54)	60,50 (2.38)	29,60 (1.17)	8,80 (0.35)	19,00 (0.75)
1S10MCA10	-10	97,80 (3.85)	68,40 (2.69)	33,60 (1.32)	11,50 (0.45)	22,00 (0.87)
1S12MCA12	-12	110,20 (4.34)	80,00 (3.15)	40,70 (1.60)	13,90 (0.55)	31,00 (1.22)
1S16MCA16	-16	136,10 (5.36)	101,70 (4.00)	52,50 (2.07)	19,90 (0.78)	38,00 (1.50)

90° Nipple Assembly 1S\_MCB\_

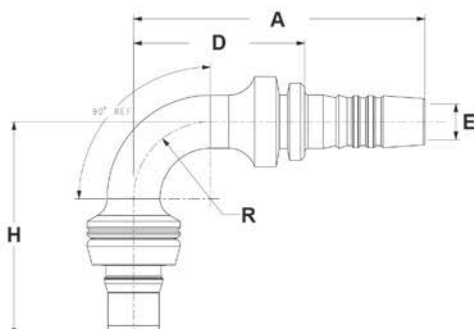

90° Part No.	Dash Size	A	D	H	EØ	R
		mm (in.)	mm (in.)	mm (in.)	mm (in.)	mm (in.)
1S4MCB4	-04	53,00 (2.09)	29,60 (1.17)	36,10 (1.42)	4,20 (0.17)	13,00 (0.51)
1S6MCB4	-04	56,20 (2.21)	32,80 (1.29)	39,60 (1.56)	4,20 (0.17)	14,00 (0.55)
1S6MCB6	-06	59,30 (2.33)	34,00 (1.34)	39,60 (1.56)	6,40 (0.25)	14,00 (0.55)
1S8MCB6	-08	66,40 (2.61)	41,10 (1.62)	53,00 (2.09)	6,70 (0.26)	19,00 (0.75)
1S8MCB8	-08	72,00 (2.83)	42,30 (1.67)	53,00 (2.09)	8,80 (0.35)	19,00 (0.75)
1S10MCB8	-08	78,10 (3.07)	48,40 (1.91)	60,40 (2.38)	9,60 (0.38)	22,00 (0.87)
1S8MCB10	-10	72,00 (2.83)	42,60 (1.68)	53,00 (2.09)	8,80 (0.35)	19,00 (0.75)
1S10MCB10	-10	77,90 (3.07)	48,50 (1.91)	60,40 (2.38)	11,50 (0.45)	22,00 (0.87)
1S12MCB12	-12	88,70 (3.49)	58,50 (2.30)	75,70 (2.98)	13,90 (0.55)	31,00 (1.22)
1S16MCB16	-16	107,30 (4.22)	72,90 (2.87)	90,00 (3.54)	19,90 (0.78)	38,00 (1.50)

# Male Global Crimp Hose Nipples

## For use with the following clamps and sockets:

Clamp: 2661 (-12 thru -16), FC619 (-12 thru -16)

Socket 1SA: 2681, FC310, FC510, FC639 (-4 thru -8), GH194, GH663, GH681

Socket 1SB: 1529, 2766, 2781, FC372 (-4 thru -16), FC373 (-4 thru -16), FC466, FC498, FC579, FC639 (-10 thru -16), FC735, FC839B, FC849, FC849B, GH120, GH195, GH683 (-4 thru -6), GH781, GH793

## Long Drop 90° Nipple Assembly 1S\_MCC\_

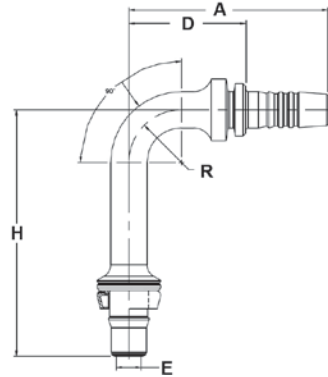

45° Part No.	Dash Size	A	D	H	EØ	R
		mm (in.)	mm (in.)	mm (in.)	mm (in.)	mm (in.)
1B12MCC12	-12	88,70 (3.49)	58,50 (2.30)	123,70 (4.87)	14,00 (0.55)	31,00 (1.22)

# Female Global Crimp Hose Nipples

## For use with the following clamps and sockets:

Clamp: 2661 (-12 thru -16), FC619 (-12 thru -16)

Socket 1SA: 2681, FC310, FC510, FC639 (-4 thru -8), GH194, GH663, GH681

Socket 1SB: 1529, 2766, 2781, FC372 (-4 thru -16), FC373 (-4 thru -16), FC466, FC498, FC579, FC639 (-10 thru -16), FC735, FC839B, FC849, FC849B, GH120, GH195, GH683 (-4 thru -6), GH781, GH793

## Straight Nipple Assembly 1S\_FC\_

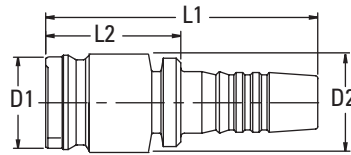

Straight Part No.	D1	D2	L1	L2	
		mm (in.)	mm (in.)	mm (in.)	mm (in.)
1S8 FC8	20.3 (0.80)	21.0 (0.83)	59.0 (2.32)	29.3 (1.15)	
1S12 FC12	31.2 (1.23)	32.0 (1.26)	67.3 (2.65)	37.1 (1.46)	

## 45° Nipple Assembly 1S\_FCA\_

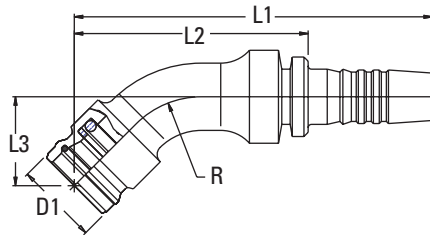

45° Part No.	D1	L1	L2	L3	R
		mm (in.)	mm (in.)	mm (in.)	mm (in.)
1S8 FCA8	20.3 (0.80)	85.6 (3.37)	55.98 (2.20)	21.3 (0.84)	19.0 (0.75)
1S12 FCA12	31.2 (1.23)	111.6 (4.39)	81.4 (3.20)	32.8 (1.29)	38.1 (1.50)

## 90° Nipple Assembly 1S\_FCB\_

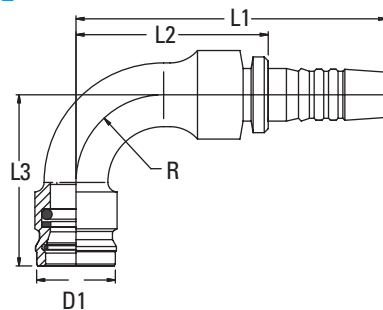

90° Part No.	D1	L1	L2	L3	R
		mm (in.)	mm (in.)	mm (in.)	mm (in.)
1S8 FCB8	20.3 (0.80)	78.0 (3.07)	48.2 (1.90)	43.0 (1.69)	22.2 (0.87)
1S12 FCB12	31.2 (1.23)	102.4 (4.03)	72.1 (2.84)	68.7 (2.70)	38 (1.50)

# TTC Crimp Fittings

## For use with TTC Fittings:

2661 (-12 and -16), FC310, FC414, FC510, FC579, FC611, FC619, FC639 (-4 thru -12), FC693, FC735, FC839B, FC849, FC849B, GH194, GH663, GH681-6, GH683, GH781, GH793

### Straight Fitting Assembly 1A\_MC\_

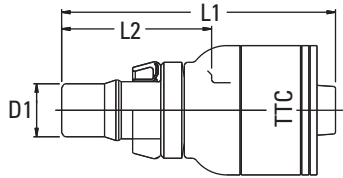

#### Straight Part No.

	D1	L1	L2
	mm (in.)	mm (in.)	mm (in.)
1A4MC4	4.2 (0.17)	49.9 (1.97)	26.5 (1.04)
1A6MC4	6.7 (0.26)	55.5 (2.19)	30.2 (1.19)
1A8MC6	9.6 (0.38)	60.0 (2.39)	30.2 (1.39)
1A8MC8	9.6 (0.38)	66.3 (2.61)	36.6 (1.44)
1A10MC10	12.8 (0.50)	69 (2.72)	39.6 (1.56)
1A12MC12	15.5 (0.61)	74.6 (2.94)	44.4 (1.75)
1A16MC16	20.7 (0.82)	83.7 (3.30)	49.3 (1.94)

### 45° Fitting Assembly 1A\_MCA\_

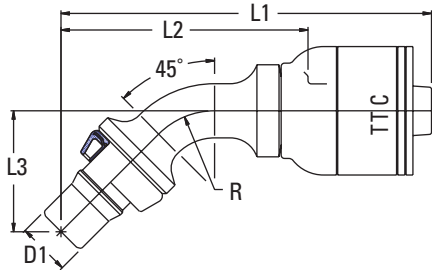

#### 45°

Part No.	D1	L1	L2	L3	R
	mm (in.)	mm (in.)	mm (in.)	mm (in.)	mm (in.)
1A6MCA6	6.7 (0.26)	72.6 (2.87)	47.3 (1.87)	22.2 (0.87)	14.0 (0.55)
1A8MCA8	8.8 (0.35)	89.9 (3.54)	60.2 (2.37)	29.6 (1.17)	19 (0.75)
1A10MCA10	11.5 (0.45)	97.8 (3.85)	68.4 (2.69)	33.6 (1.32)	22.0 (0.87)
1A12MCA12	13.9 (0.55)	110.2 (4.34)	80.0 (3.15)	40.7 (1.60)	31.0 (1.22)
1A16MCA16	19.9 (0.78)	131.5 (5.18)	97.1 (3.82)	47.9 (1.89)	38 (1.50)

### 90° Fitting Assembly 1A\_MCB\_

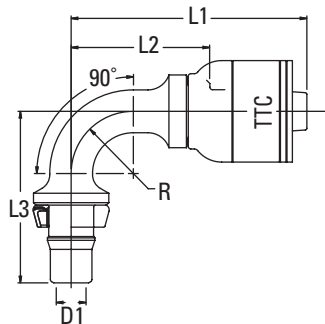

#### 90°

Part No.	D1	L1	L2	L3	R
	mm (in.)	mm (in.)	mm (in.)	mm (in.)	mm (in.)
1A4MCB4	4.2 (0.17)	53.1 (2.09)	29.6 (1.17)	36.1 (1.42)	13 (0.51)
1A6MCB6	6.7 (0.26)	59.3 (2.33)	34 (1.34)	39.6 (1.56)	14 (0.55)
1A8MCB8	8.8 (0.35)	72 (2.83)	42.3 (1.67)	53 (2.09)	19 (0.75)
1A10MCB10	11.5 (0.45)	77.9 (3.07)	48.5 (1.91)	60.4 (2.36)	22 (0.87)
1A12MCB12	13.9 (0.55)	88.7 (3.49)	58.5 (2.30)	75.7 (2.98)	31 (1.22)
1A16MCB16	19.9 (0.78)	107.3 (4.22)	72.9 (2.87)	90 (3.54)	38 (1.50)

# TTC12 Crimp Fittings

For use with TTC12 Fittings:

GH493, FC736

Straight Fitting Assembly  
1A\_MC\_

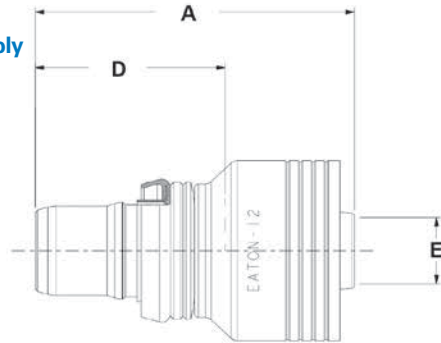

Straight Part No.	Dash Size	A	D	E Ø
		mm (in.)	mm (in.)	mm (in.)
1B6MC6	-06	55,50 (2.19)	30,20 (1.19)	6,70 (0.26)
1B8MC8	-08	66,30 (2.61)	36,60 (1.44)	9,60 (0.38)
1B10MC10	-10	69,00 (2.72)	39,60 (1.56)	12,80 (0.50)
1B12MC12	-12	74,60 (2.94)	44,40 (1.75)	15,5 (0.61)
1B16MC16	-16	83,70 (3.30)	49,30 (1.94)	20,70 (0.82)

45° Fitting Assembly 1A\_MCA\_

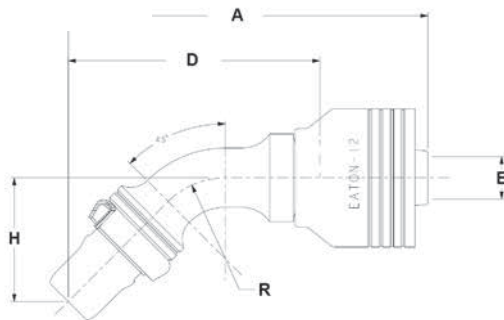

45° Part No.	Dash Size	A	D	H	E Ø	R
		mm (in.)	mm (in.)	mm (in.)	mm (in.)	mm (in.)
1B6MCA6	-06	72,90 (2.87)	47,60 (1.87)	22,20 (0.87)	6,40 (0.25)	14,00 (0.55)
1B8MCA8	-08	89,90 (3.54)	60,20 (2.37)	29,60 (1.17)	8,80 (0.35)	19,00 (0.75)
1B10MCA10	-10	97,80 (3.85)	68,40 (2.69)	33,60 (1.32)	11,60 (0.46)	22,00 (0.87)
1B12MCA12	-12	110,20 (4.34)	80,00 (3.15)	40,70 (1.60)	13,90 (0.55)	31,00 (1.22)
1B16MCA16	-16	136,10 (5.36)	101,70 (4.00)	52,50 (2.07)	19,90 (0.78)	38,00 (1.50)

90° Fitting Assembly 1A\_MCB\_

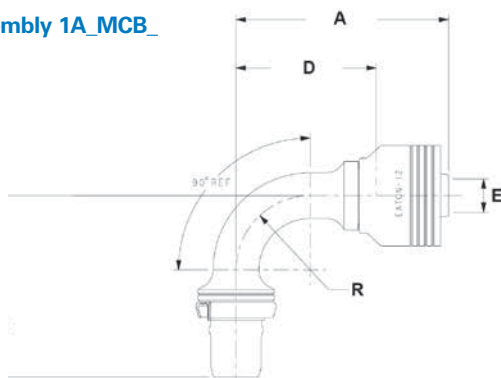

90° Part No.	Dash Size	A	D	H	E Ø	R
		mm (in.)	mm (in.)	mm (in.)	mm (in.)	mm (in.)
1B6MCB6	-06	59,30 (2.33)	34,00 (1.34)	39,60 (1.56)	6,40 (0.25)	14,00 (0.55)
1B8MCB8	-08	72,00 (2.83)	42,30 (1.67)	53,00 (2.09)	8,80 (0.35)	19,00 (0.75)
1B10MCB10	-10	77,80 (3.06)	48,40 (1.91)	60,40 (2.38)	11,60 (0.46)	22,00 (0.87)
1B12MCB12	-12	88,70 (3.49)	58,50 (2.30)	75,70 (2.98)	13,90 (0.55)	31,00 (1.22)
1B16MCB16	-16	107,30 (4.22)	72,90 (2.87)	90,00 (3.54)	19,90 (0.78)	38,00 (1.50)

90° Fitting Assembly 1A\_

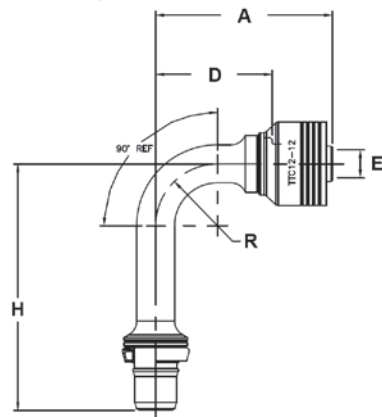

Long Drop 90° Part No.	Dash Size	A	D	H	E Ø	R
		mm (in.)	mm (in.)	mm (in.)	mm (in.)	mm (in.)
1B12MCB12	-12	88,70 (3.49)	58,50 (2.30)	123,70 (2.98)	14,00 (0.55)	31,00 (1.22)

# Crimp Nipples for FC699 Hose

Nipples for use with FW1097 Sockets and FC699 Hose

## Straight Nipple Assembly FJ4823

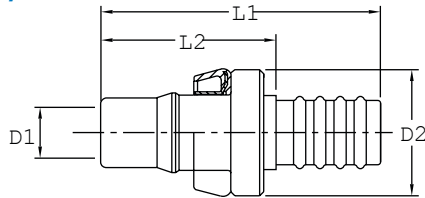

### Straight

Part No.	D1	D2	L1	L2
	mm (in.)	mm (in.)	mm (in.)	mm (in.)
FJ4823-0604S*	4.4 (0.17)	18 (0.71)	41.6 (1.64)	25.6 (1.01)
FJ4823-0606S	6.6 (0.26)	18 (0.71)	43.2 (1.68)	26 (1.02)
FJ4823-0808S	9.6 (0.38)	23 (0.91)	51.6 (2.03)	32.3 (1.27)
FJ4823-0810S	9.6 (0.38)	23 (0.91)	52 (2.05)	32 (1.28)
FJ4823-1010S	12.3 (0.48)	24 (0.94)	55.5 (2.18)	35.4 (1.39)
FJ4823-1212S	15.5 (0.61)	32 (1.26)	60.4 (2.38)	39.8 (1.57)

\* MTO

## 45° Nipple Assembly FJ4822

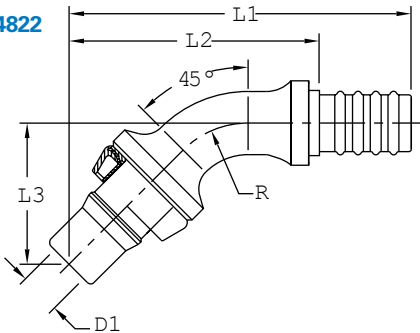

### 45°

Part No.	D1	L1	L2	L3	R
	mm (in.)	mm (in.)	mm (in.)	mm (in.)	mm (in.)
FJ4822-0606S	6.7 (0.26)	57.8 (2.27)	40.7 (1.60)	22.2 (0.87)	14 (0.55)
FJ4822-0808S	9.1 (0.36)	71.2 (2.80)	52.2 (2.06)	29.2 (1.16)	19 (0.75)
FJ4822-1010S	11.5 (0.45)	80.4 (3.16)	60.3 (2.37)	33.6 (1.32)	22 (0.87)
FJ4822-1212S	13.9 (0.55)	92 (3.62)	71.4 (2.81)	40.7 (1.60)	31 (1.22)

## 90° Nipple Assembly FJ4824

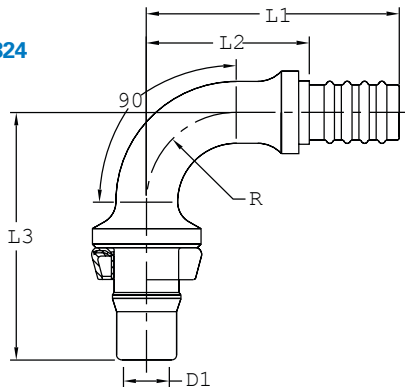

### 90°

Part No.	D1	L1	L2	L3	R
	mm (in.)	mm (in.)	mm (in.)	mm (in.)	mm (in.)
FJ4824-0606S	6.7 (0.26)	44.3 (1.74)	27.1 (1.07)	39.6 (1.56)	14 (0.55)
FJ4824-0808S	8.8 (0.35)	53.5 (2.10)	34.4 (1.36)	53 (2.09)	19 (0.75)
FJ4824-1010S	11.5 (0.45)	60.4 (2.38)	40.4 (1.59)	60.4 (2.38)	22 (0.87)
FJ4824-1212S	13.9 (0.55)	70.6 (2.78)	50 (1.97)	75.7 (2.98)	31 (1.22)

## Long Drop 90° Nipple Assembly FJ2004

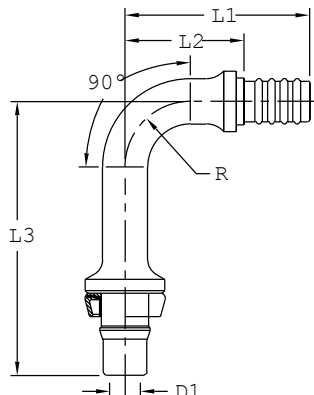

### Long Drop 90°

Part No.	D1	L1	L2	L3	R
	mm (in.)	mm (in.)	mm (in.)	mm (in.)	mm (in.)
FJ2004-0606S*	6.7 (0.26)	44.3 (1.74)	27.1 (1.07)	70.2 (2.76)	14 (0.55)
FJ2004-0808S	9.1 (0.36)	53.5 (2.10)	34.4 (1.36)	88 (3.46)	19 (0.75)
FJ2004-1010S*	11.5 (0.45)	60.4 (2.38)	40.4 (1.59)	98.4 (3.87)	22 (0.87)
FJ2004-1212S*	13.9 (0.55)	70.6 (2.78)	50 (1.97)	123.7 (4.87)	31 (1.22)

\* MTO

# Crimp Nipples for Teflon® Hose

Teflon® Crimp Nipples for use with 2807 & FC465  
Hose and Sockets FC3443 & FC3596

## Straight Nipple Assembly FJ4828

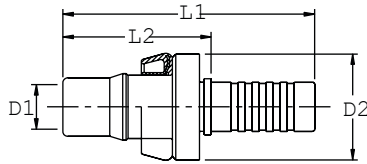

### Straight

Part No.	D1	D2	L1	L2
	mm (in.)	mm (in.)	mm (in.)	mm (in.)
FJ4828-0606S	6.3 (0.25)	18 (0.71)	40.1 (1.58)	27.7 (1.09)
FJ4828-0808S	8.8 (0.35)	23 (0.91)	55.3 (2.18)	32.8 (1.29)
FJ4828-1010S	11.1 (0.44)	24 (0.94)	58.1 (2.29)	35.6 (1.40)
FJ4828-1212S	14.3 (0.56)	32 (1.26)	62.5 (2.46)	40.0 (1.57)

## 45° Nipple Assembly FJ2015

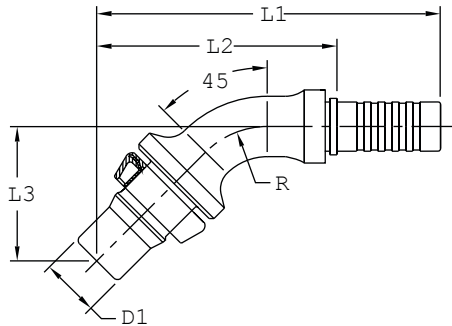

### 45°

Part No.	D1	L1	L2	L3	R
	mm (in.)	mm (in.)	mm (in.)	mm (in.)	mm (in.)
FJ2015-0606S	6.3 (0.25)	53.7 (2.10)	41.1 (1.61)	21.1 (0.87)	14 (0.55)
FJ2015-0808S	8.8 (0.35)	75 (2.95)	52.6 (2.07)	29.6 (1.17)	19 (0.75)
FJ2015-1010S	11.1 (0.44)	83.1 (3.27)	60.6 (2.39)	33.6 (1.32)	22 (0.87)
FJ2015-1212S	13.9 (0.55)	94.2 (3.71)	71.7 (2.82)	40.7 (1.60)	31 (1.22)

## 90° Nipple Assembly FJ2036

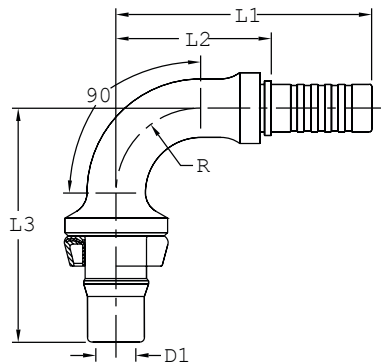

### 90°

Part No.	D1	L1	L2	L3	R
	mm (in.)	mm (in.)	mm (in.)	mm (in.)	mm (in.)
FJ2036-0606S	6.3 (0.25)	40 (1.58)	27.6 (1.09)	39.2 (1.56)	14 (0.55)
FJ2036-0808S	8.8 (0.35)	57.2 (2.25)	34.7 (1.37)	53 (2.09)	19 (0.75)
FJ2036-1010S	11.1 (0.44)	63.1 (2.49)	40.7 (1.60)	60.4 (2.38)	22 (0.87)
FJ2036-1212S	13.9 (0.55)	72.8 (2.87)	50.3 (1.98)	75.7 (2.98)	31 (1.22)

## Long Drop 90° Nipple Assembly FJ4999

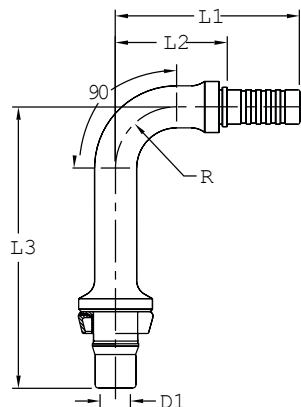

### Long Drop 90°

Part No.	D1	L1	L2	L3	R
	mm (in.)	mm (in.)	mm (in.)	mm (in.)	mm (in.)
FJ4999-0606S	6.3 (0.25)	40 (1.58)	27.6 (1.09)	70.2 (2.76)	14 (0.55)
FJ4999-0808S	8.8 (0.35)	57.2 (2.25)	34.7 (1.37)	87.4 (3.44)	19 (0.75)
FJ4999-1010S	11.1 (0.44)	63.1 (2.49)	40.7 (1.60)	98.4 (3.87)	22 (0.87)
FJ4999-1212S	13.9 (0.55)	72.8 (2.86)	50.3 (1.93)	123.7 (4.87)	31 (1.22)

Teflon® is a registered trademark of DuPont used under license by Eaton.

# OTC Crimp Fittings

OTC Crimp Fittings for use with 2583, 2661, FC466, FC498, FC619, and FC699, GH100 Hose

## Straight Fitting Assembly 1G\_MC\_

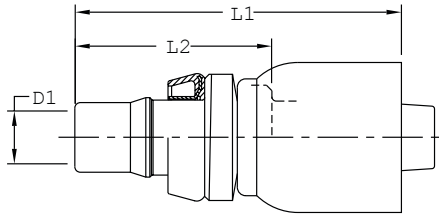

### Straight

Part No.	D1	L1	L2
	mm (in.)	mm (in.)	mm (in.)
1G6MC4	4.2 (0.17)	48.1 (1.89)	29.2 (1.15)
1G6MC6*	6.7 (0.26)	50.6 (1.99)	30.6 (1.20)
1G8MC8	9.6 (0.38)	60.3 (2.37)	36.6 (1.44)
1G10MC10	12.8 (0.50)	69 (2.72)	39.6 (1.56)
1612MC12	15.5 (0.61)	68 (2.68)	44.4 (1.75)
1G16MC16	20.7 (0.82)	83.7 (3.30)	49.3 (1.94)

\* MT0

## 45° Fitting Assembly 1G\_MCA\_

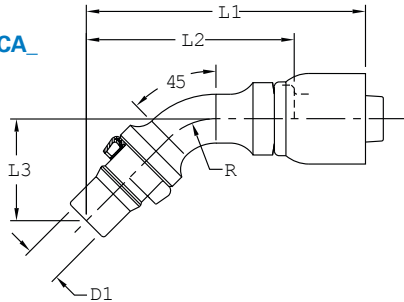

### 45°

Part No.	D1	L1	L2	L3	R
	mm (in.)	mm (in.)	mm (in.)	mm (in.)	mm (in.)
1G10MCA10	11.5 (0.45)	91.9 (3.62)	68.4 (2.69)	33.6 (1.32)	22 (0.87)
1G6MCA6	6.4 (0.25)	72.9 (2.87)	47.6 (1.87)	22.2 (0.87)	14 (0.55)

## 90° Fitting Assembly 1G\_MCB\_

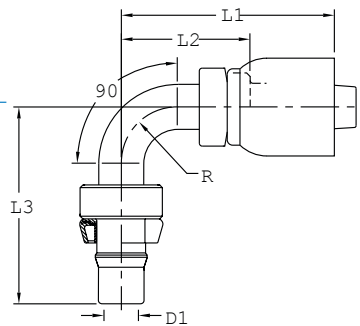

### 90°

Part No.	D1	L1	L2	L3	R
	mm (in.)	mm (in.)	mm (in.)	mm (in.)	mm (in.)
1G6MCB4	4.2 (0.17)	51.8 (2.04)	32.8 (1.29)	39.7 (1.56)	14 (0.55)
1G6MCB6	6.4 (0.25)	59.3 (2.33)	34 (1.34)	39.6 (1.56)	14 (0.55)
1G8MCB8	9.4 (0.37)	59.7 (2.35)	36 (1.42)	55.7 (2.19)	15.9 (0.63)
1G10MCB10	11.5 (0.45)	71.9 (2.83)	48.5 (1.91)	60.4 (2.38)	22 (0.87)
1G12MCB12	13.9 (0.55)	82.1 (3.23)	58.5 (2.30)	75.7 (2.98)	31 (1.22)

## Long Drop 90° Fitting Assembly FJ3005

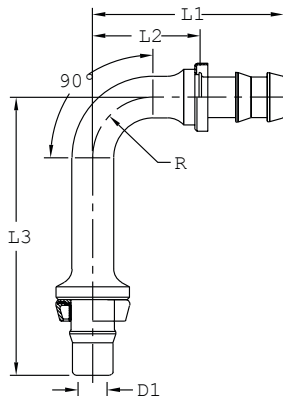

### Long Drop 90°

Part No.	D1	L1	L2	L3	R
	mm (in.)	mm (in.)	mm (in.)	mm (in.)	mm (in.)
1G12MCC12	13.8 (0.54)	81 (3.19)	58.5 (2.30)	123.7 (4.87)	31 (1.22)

# Crimp Fittings for SAE 100R5 Hose

Crimp Fittings for use with 1503, FC234, FC300, FC350, and FC355 Hose

## Straight Fitting Assembly FJ3020

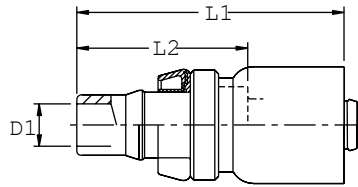

### Straight Part No.

Part No.	D1 mm (in.)	L1 mm (in.)	L2 mm (in.)
FJ3020-0606S*	5.9 (0.23)	51 (2.01)	30.8 (1.21)
FJ3020-0808S*	7.2 (0.28)	55.9 (2.20)	35.8 (1.41)
FJ3020-1010S*	9.6 (0.38)	61.7 (2.43)	39.3 (1.55)
FJ3020-1212S	12.7 (0.50)	66.1 (2.60)	43.7 (1.72)
FS30201616S	20.6 (0.81)	82.6 (3.25)	57.5 (2.26)

\* MTO

## 45° Fitting Assembly FJ3021

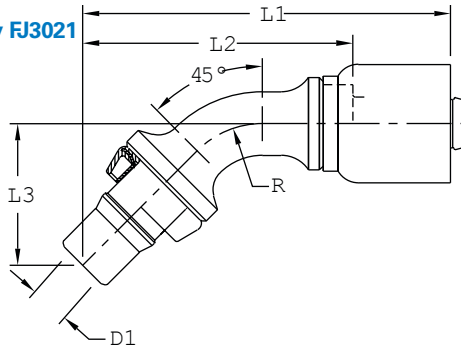

### 45° Part No.

Part No.	D1 mm (in.)	L1 mm (in.)	L2 mm (in.)	L3 mm (in.)	R mm (in.)
FJ3021-0606S*	5.9 (0.23)	64.5 (2.54)	44.4 (1.75)	21.9 (0.86)	14 (0.55)
FJ3021-0808S*	7.2 (0.28)	75.9 (2.99)	55.6 (2.19)	29.2 (1.15)	19 (0.75)
FJ3021-1010S*	9.6 (0.38)	86.7 (3.41)	64.3 (2.53)	33.6 (1.32)	22 (0.87)
FJ3021-1212S*	12.7 (0.50)	97.8 (3.85)	75.4 (2.97)	40.7 (1.60)	31 (1.22)

\* MTO

## 90° Fitting Assembly FJ3022

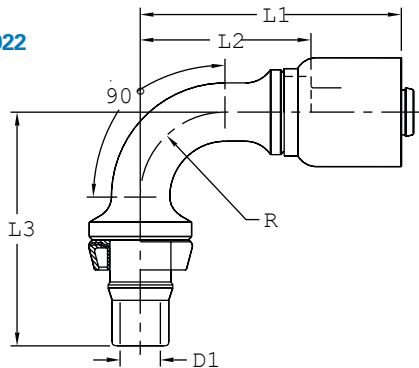

### 90° Part No.

Part No.	D1 mm (in.)	L1 mm (in.)	L2 mm (in.)	L3 mm (in.)	R mm (in.)
FJ3022-0606S*	5.9 (0.23)	51.3 (2.02)	31.2 (1.23)	39.2 (1.54)	14 (0.55)
FJ3022-0808S*	7.2 (0.28)	58.5 (2.30)	38.3 (1.51)	52.4 (2.06)	19 (0.75)
FJ3022-1010S*	9.6 (0.38)	66.7 (2.63)	44.3 (1.74)	60.4 (2.38)	22 (0.87)
FJ3022-1212S	12.7 (0.50)	76.4 (3.01)	54 (2.12)	75.7 (2.98)	31 (1.22)

\* MTO

## Long Drop 90° Fitting Assembly FJ3023

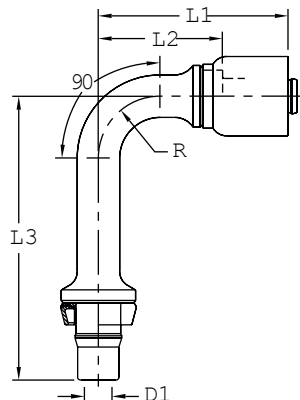

### Long Drop 90° Part No.

Part No.	D1 mm (in.)	L1 mm (in.)	L2 mm (in.)	L3 mm (in.)	R mm (in.)
FJ3023-0606S*	5.9 (0.23)	51.3 (2.02)	31.2 (1.23)	70.2 (2.76)	14 (0.55)
FJ3023-0808S*	7.2 (0.28)	58.5 (2.30)	38.3 (1.51)	87.4 (3.44)	19 (0.75)
FJ3023-1010S*	9.6 (0.38)	66.7 (2.63)	44.3 (1.74)	98.4 (3.87)	22 (0.87)
FJ3023-1212S*	12.7 (0.50)	76.4 (3.01)	54 (2.12)	123.7 (4.87)	31 (1.22)

\* MTO

# STC Socketless Fittings

For use with 2556, 2565, 2575, H201, FC332, FC647 Hose

## Straight Fitting Assembly FJ5783

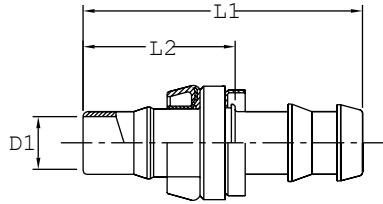

### Straight Part No.

Part No.	D1	L1	L2
	mm (in.)	mm (in.)	mm (in.)
FJ5783-0606S*	7.5 (0.30)	47.9 (1.89)	26 (1.02)
FJ5783-0608S*	6.7 (0.26)	53 (2.09)	27.2 (1.07)
FJ5783-0808S*	9.9 (0.39)	56.6 (2.23)	30.9 (1.22)
FJ5783-1010S*	12.3 (0.48)	74.7 (2.94)	35.6 (1.40)
FJ5783-1212S	15.5 (0.61)	78.7 (3.10)	40.1 (1.58)

\* MTO

## 45° Fitting Assembly FJ3128

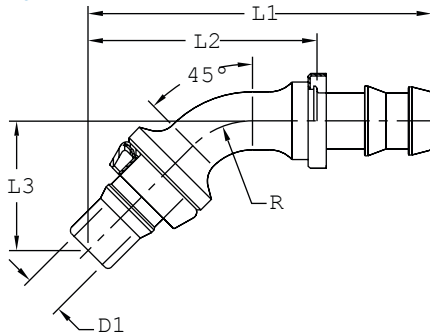

### 45° Part No.

Part No.	D1	L1	L2	L3	R
	mm (in.)	mm (in.)	mm (in.)	mm (in.)	mm (in.)
FJ3128-0606S*	6.7 (0.26)	62.3 (2.45)	40.3 (1.59)	21.9 (0.86)	14 (0.55)
FJ3128-0808S*	9.1 (0.36)	77.4 (3.05)	51.6 (2.03)	29.2 (1.15)	19 (0.75)
FJ3128-1010S*	11.5 (0.45)	99.2 (3.91)	60.1 (2.37)	33.6 (1.32)	22 (0.87)
FJ3128-1212S*	13.9 (0.55)	109.8 (4.32)	71.2 (2.80)	40.7 (1.60)	31 (1.22)

\* MTO

## 90° Fitting Assembly FJ3031

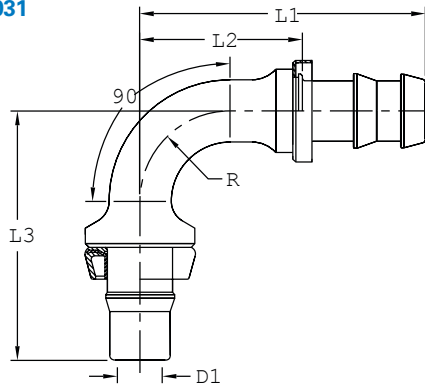

### 90° Part No.

Part No.	D1	L1	L2	L3	R
	mm (in.)	mm (in.)	mm (in.)	mm (in.)	mm (in.)
FJ3031-0606S*	6.7 (0.26)	49.1 (1.93)	27.1 (1.07)	39.2 (1.54)	14 (0.55)
FJ3031-0808S*	9.1 (0.36)	60 (2.36)	34.2 (1.35)	52.4 (2.06)	19 (0.75)
FJ3031-1010S*	11.5 (0.45)	79.3 (3.12)	40.2 (1.58)	60.4 (2.38)	22 (0.87)
FJ3031-1212S*	13.9 (0.55)	88.3 (3.48)	49.8 (1.96)	75.7 (2.98)	31 (1.22)

\* MTO

## Long Drop 90° Fitting Assembly FJ3005

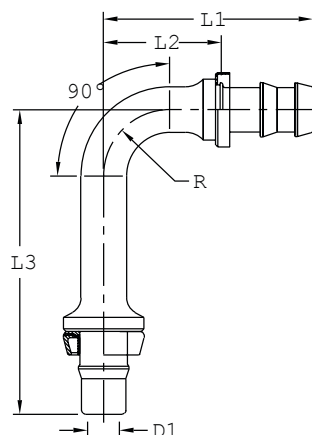

### Long Drop 90° Part No.

Part No.	D1	L1	L2	L3	R
	mm (in.)	mm (in.)	mm (in.)	mm (in.)	mm (in.)
FJ3005-0606S*	6.7 (0.26)	49.1 (1.93)	27.1 (1.07)	70.2 (2.76)	14 (0.55)
FJ3005-0808S*	9.1 (0.36)	60 (2.36)	34.2 (1.35)	87.4 (3.44)	19 (0.75)
FJ3005-1010S*	11.5 (0.45)	79.3 (3.12)	40.2 (1.58)	98.4 (3.87)	22 (0.87)
FJ3005-1212S*	13.9 (0.55)	88.3 (3.48)	49.8 (1.96)	123.7 (4.87)	31 (1.22)

\* MTO

# Female STC Cap and Male STC Plug

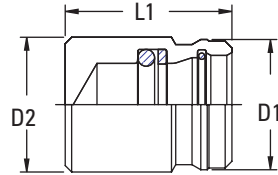

**Note:**  
Female STC Cap can hold pressure equal to the operating pressure of the particular STC size.

<b>Part No.</b>	<b>D1</b>	<b>L1</b>	<b>D2</b>
	<b>mm (in.)</b>	<b>mm (in.)</b>	<b>mm (in.)</b>
FF 90202-06S	17 (0.67)	18 (0.71)	21.1 (0.83)
FF 90202-08S	20.3 (0.80)	21 (0.83)	26.8 (1.06)
FF 90202-10S	24.4 (0.96)	25 (0.99)	33 (1.30)
FF 90202-12S	31.3 (1.24)	32 (1.26)	36.7 (1.45)
FF 90202-16S	39.0 (1.54)	50.9 (2.00)	41 (1.61)

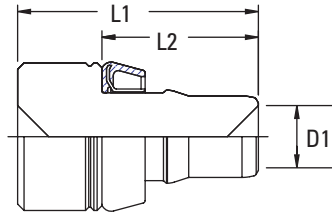

**Note:**  
Male STC Plug can hold pressure equal to the operating pressure of the particular STC size.

<b>Part No.</b>	<b>D1</b>	<b>L1</b>	<b>L2</b>
	<b>mm (in.)</b>	<b>mm (in.)</b>	<b>mm (in.)</b>
FF 90384-06S	6.8 (0.27)	31.2 (1.23)	19.2 (0.76)
FF 90384-08S	9.7 (0.38)	37.5 (1.48)	24.4 (0.96)
FF 90384-10S	11.5 (0.45)	42.4 (1.68)	27.2 (1.08)
FF 90384-12S	15.6 (0.62)	46.8 (1.85)	31.6 (1.25)
FF 90384-16S	20.6 (0.81)	51.9 (2.05)	36.0 (1.42)

# Brazed Male and Female STC on High Pressure Carbon Steel Tubing



Eaton offers high-pressure tubing with male STC and female STC end configurations. The male and female STC ends are attached to the high-pressure tubing using brazing techniques. The brazing process does not affect the performance characteristics of the STC connection, but the rated performance of the assembly will be at the lowest pressure rated component level.

**Operating Pressure Of High Pressure Tubing W/ Brazed STC Ends - Most Common Combinations - (SAE J356, J524, J525, J526, J527)**

Tube O.D.	Dash Size STC	Tubing Wall Thickness (IN.) and Pressure in PSI							
		.028	.035	.049	.065	.083	.095	.109	.120
.38	-06	2,000	2,250	5,000	5,000	5,000	-	-	
.50	-08	-	1,850	2,700	3,650	4,250	4,250	4,250	4,250
.62	-10	-	1,500	2,100	2,850	3,750	4,000	4,000	4,000
.75	-12	-	1,200	1,750	2,350	3,050	3,550	4,000	4,000
1.00	-16	-	900	1,300	1,750	2,250	2,600	3,000	3,350



### Characteristics

- Sizes available: -6 up to -16
- 4:1 safety factor
- Compatible with machined STC
- Can be used in conjunction with Eaton hose for hose/tube combinations
- 28 in./Hg vacuum capable
- Temperature: -40°F to +300°F

### Note:

Contact Eaton for availability and application information.

### Applications:

- Air Conditioning
- Engine & Oil
- Hydraulics

# Braze-On Female Spud for Tubes

**Note:**

O-ring, back-up ring, and latch ring must be purchased separately and assembled after brazing. See page 47 for ring information.

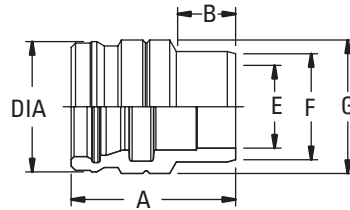

**90°**

Part No.	A	B	DIA	E	F	G
	mm (in.)	mm (in.)	mm (in.)	mm (in.)	mm (in.)	mm (in.)
FF3059-0606S	23.2 (0.91)	7.4 (0.29)	17 (0.67)	9.6 (0.38)	16 (0.63)	18 (0.71)
FF3059-0808S	28.9 (1.14)	9.3 (0.37)	20.3 (0.80)	12.8 (0.50)	19 (0.75)	21 (0.83)
FF3059-1010S	31.6 (1.25)	9.3 (0.37)	24.4 (0.96)	16.0 (0.63)	23 (0.91)	25 (0.98)
FF3059-1212S	37.3 (1.47)	8.6 (0.34)	31.2 (1.23)	19.1 (0.75)	25.4 (1.00)	32 (1.26)

# Formed Male STC Tubing (Carbon Steel)

Eaton offers low pressure tubing with male STC end configurations for use with steel tubing that meets SAEJ525 specifications. The product design has been subjected to a full test regimen. Reusability has been proven by testing this product to many cycles of connection and disconnection.

## Advantages

- Eliminates the braze joints and potential leak paths
- Reduced weight compared to standard STC connections
- Formed male is an integral part of the tubing
- Can be used with standard STC female connections
- Can be used in conjunction with formed hose nipples used with FC699 and FC498 hoses

## Note:

*Minimum straight tangent of the tube bends not to be below 2 x O.D. on all sizes measured from the front of the bead.*

## Characteristics

- Sizes available: -6, -8, -10, -12
- Maximum operating pressure of 500 psi
- 4:1 safety factor
- Use with hydraulic fluids, air, water, fuel, and refrigerants\*
- 28 In./Hg vacuum capable
- Temperatures of: -40°F to +300°\*

\* Check the o-ring seal material to ensure that the elastomer is compatible with your intended application. See page 8 for details.

## Applications:

- Air Conditioning
- Steering
- Engine & Oil
- Low Pressure Hydraulics

Tubing wall thicknesses are as follows:

Size	Tubing Thickness
-6	0.035"
-8	0.035"
-10	0.049"
-12	0.049"

Distance from formed male nose to the front of the rear bead:

Size	L <sub>1</sub> mm (in.)
-6	18.9 (0.74)
-8	23.8 (0.94)
-10	27.2 (1.07)
-12	31.6 (1.24)

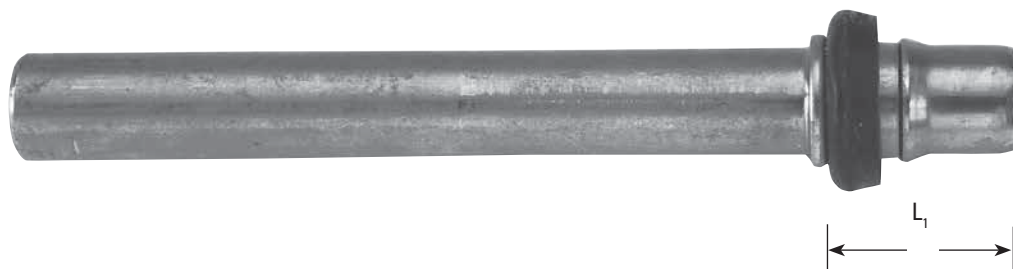

Contact Eaton for availability and application information.

# Adapters

## Male SAE O-Ring Boss to Female STC

STC adapters come standard with nitrile o-rings. See page 8 for seal options.

### Straight FF3042

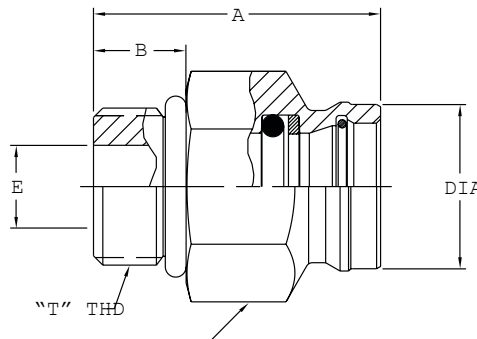

Straight Part No.	A	B	DIA	E	HEX	"T" THD
	mm (in.)	mm (in.)	mm (in.)	mm (in.)	mm (in.)	mm (in.)
FF342-0404-523	26.8 (1.06)	9.1 (0.36)	14.6 (0.51)	4.4 (0.17)	16.0 (0.65)	7/16 20 2A
FF3042-0406S	30 (1.18)	9.1 (0.36)	17 (0.67)	4.4 (0.17)	19 (0.75)	7/16- 20 2A
FF3042-0606S	28.7 (1.13)	9.9 (0.39)	17 (0.67)	7.5 (0.30)	19 (0.75)	9/16- 18 2A
FF3042-0608S	33.7 (1.33)	9.9 (0.39)	20.3 (0.80)	7.5 (0.30)	21 (0.83)	9/16- 18 2A
FF3042-0806S	29.9 (1.18)	11.1 (0.44)	17 (0.67)	9.9 (0.39)	25 (0.98)	3/4-16 2A
FF3042-0808S	34.5 (1.36)	11.1 (0.44)	20.3 (0.80)	9.9 (0.39)	24 (0.94)	3/4-16 2A
FF3042-0810S	36.5 (1.44)	11.1 (0.44)	24.4 (0.96)	10 (0.39)	25.4 (1.00)	3/4-16 2A
FF3042-1008S	35 (1.38)	12.7 (0.50)	20.3 (0.80)	12.3 (0.48)	27 (1.06)	7/8-14 2A
FF3042-1010S	38 (1.50)	12.7 (0.50)	24.4 (0.96)	12.3 (0.48)	27 (1.06)	7/8-14 2A
FF3042-1012S	44.6 (1.76)	12.7 (0.50)	31.3 (1.23)	12.3 (0.48)	32 (1.26)	7/8-14 2A
FF3042-1210S	40.4 (1.59)	15.1 (0.59)	24.4 (0.96)	15.5 (0.61)	32 (1.26)	1 1/16- 12 2A
FF3042-1212S	47 (1.85)	15.1 (0.59)	31.2 (1.23)	15.5 (0.61)	32 (1.26)	1 1/16- 12 2A
FF3042-1616S	50.9 (2.00)	15.1 (0.59)	41 (1.61)	21.4 (0.84)	41 (1.62)	1 5/16- 12 2A

### 45° Adjustable FF3038

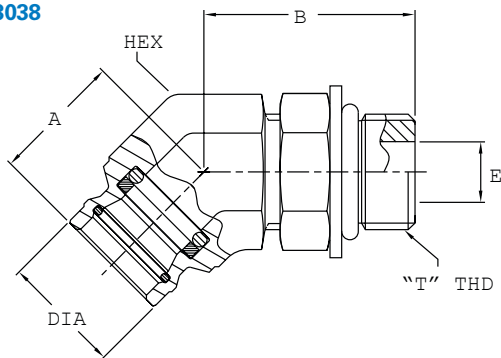

45° Part No.	A	B	DIA	E	HEX	"T" THD
	mm (in.)	mm (in.)	mm (in.)	mm (in.)	mm (in.)	mm (in.)
FF3038-0406S	18.5 (0.73)	28.4 (1.12)	17 (0.67)	4.4 (0.17)	19 (0.75)	7/16- 20 2A
FF3038-0606S	18.5 (0.73)	30 (1.18)	17 (0.67)	7.5 (0.30)	19 (0.75)	9/16- 18 2A
FF3038-0808S	21.4 (0.84)	34.5 (1.36)	20.3 (0.80)	9.9 (0.39)	22 (0.86)	3/4-16 2A
FF3038-1010S	23.1 (0.91)	42.5 (1.67)	24.4 (0.96)	12.3 (0.48)	27 (1.05)	7/8-14 2A

### 90° Adjustable FF3046

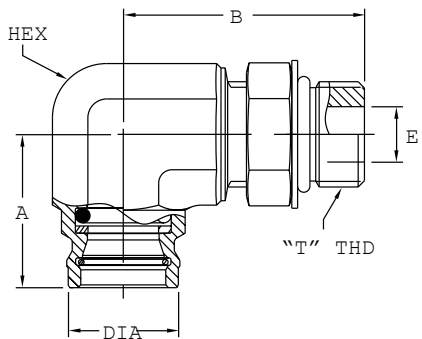

90° Part No.	A	B	DIA	E	HEX	"T" THD
	mm (in.)	mm (in.)	mm (in.)	mm (in.)	mm (in.)	mm (in.)
FF3046-0404-523	24.9 (0.95)	32.8 (1.29)	17.0 (0.67)	4.4 (0.17)	17 (0.61)	7/16 20 2A
FF3046-0406S	27.7 (1.09)	32.8 (1.29)	17 (0.67)	4.4 (0.17)	19 (0.75)	7/16- 20 2A
FF3046-0606S	27.7 (1.09)	35.6 (1.40)	17 (0.67)	7.5 (0.30)	19 (0.75)	9/16- 18 2A
FF3046-0806S	27.5 (1.08)	43.2 (1.70)	17 (0.67)	9.9 (0.39)	22 (0.86)	3/4-16 2A
FF3046-0808S	27.5 (1.08)	43.2 (1.70)	20.3 (0.80)	9.9 (0.39)	22 (0.86)	3/4-16 2A
FF3046-1008S	30.9 (1.22)	50 (1.97)	20.3 (0.80)	12.3 (0.48)	22 (0.86)	7/8-14 2A
FF3046-1010S	31.8 (1.25)	48.2 (1.90)	24.4 (0.96)	12.3 (0.48)	27 (1.05)	7/8-14 2A
FF3046-1212S	38.1 (1.50)	55.5 (2.18)	31.2 (1.23)	15.5 (0.61)	32 (1.25)	1 1/16- 12 2A
FF3046-1616S	46.4 (1.83)	63.5 (2.50)	41 (1.61)	21.5 (0.85)	41 (1.62)	1 5/16- 12 2A

# Adapters

STC adapters come standard with nitrile o-rings. See page 8 for seal options.

## Male NPTF to Female STC

### Straight FF3089

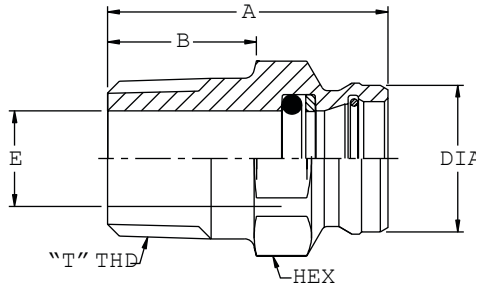

Straight Part No.	A	B	DIA	E	HEX	"T" THD
	mm (in.)	mm (in.)	mm (in.)	mm (in.)	mm (in.)	mm (in.)
FF3089-0406S	36.8 (1.45)	14.6 (0.57)	17 (0.67)	7.1 (0.28)	19 (0.75)	1/4-18
FF3089-0606S	36.8 (1.45)	14.6 (0.57)	17 (0.67)	10.3 (0.41)	19 (0.75)	3/8-18
FF3089-0608S	38.8 (1.53)	14.6 (0.57)	20.3 (0.80)	10.3 (0.41)	21 (0.83)	3/8-18
FF3089-0806S	41.6 (1.64)	19.4 (0.76)	17 (0.67)	9.7 (0.38)	22.2 (0.88)	1/2-14
FF3089-0808S	37.8 (1.49)	19.4 (0.76)	20.3 (0.80)	12.3 (0.48)	24 (0.94)	1/2-14
FF3089-0810S	43.9 (1.73)	19.4 (0.76)	24.4 (0.96)	13.5 (0.53)	25.4 (1.00)	1/2-14
FF3089-1210S	43.9 (1.73)	19.4 (0.76)	24.4 (0.96)	16.2 (0.64)	27 (1.06)	3/4-14
FF3089-1212S	44.6 (1.76)	19.4 (0.76)	31.3 (1.23)	18.3 (0.72)	32 (1.26)	3/4-14

### 45° FF3093

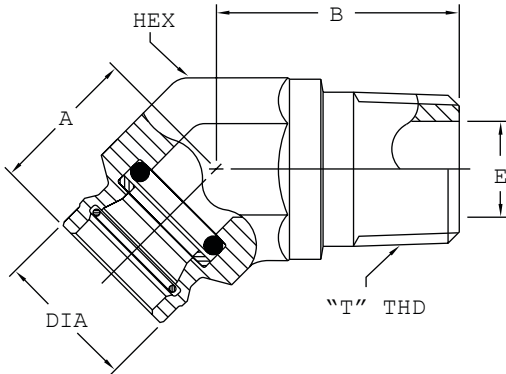

45° Part No.	A	B	DIA	E	HEX	"T" THD
	mm (in.)	mm (in.)	mm (in.)	mm (in.)	mm (in.)	mm (in.)
FF3093-0406S	18.8 (0.74)	26.7 (1.05)	17 (0.67)	7.1 (0.28)	19 (0.75)	1/4-18
FF3093-0606S	20.4 (0.80)	26.9 (1.06)	17 (0.67)	10.3 (0.41)	19 (0.75)	3/8-18
FF3093-0808S	25.6 (1.01)	34 (1.34)	20.3 (0.80)	13.5 (0.53)	22 (0.86)	1/2-14
FF3093-0810S	26.2 (1.03)	34 (1.34)	24.4 (0.96)	13.5 (0.53)	27 (1.06)	1/2-14
FF3093-1212S	32 (1.28)	35 (1.38)	31.2 (1.23)	18.3 (0.72)	32 (1.26)	3/4-14

### 90° FF3056

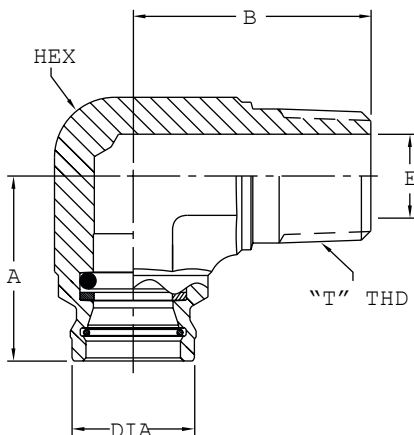

90° Part No.	A	B	DIA	E	HEX	"T" THD
	mm (in.)	mm (in.)	mm (in.)	mm (in.)	mm (in.)	mm (in.)
FF3056-0606S	27.7 (1.09)	27.5 (1.08)	17 (0.67)	10.3 (0.41)	19 (0.75)	3/8-18
FF3056-0608S	28.2 (1.11)	27.7 (1.09)	20.3 (0.80)	10.3 (0.41)	22 (0.86)	3/8-18
FF3056-0808S	29.8 (1.17)	38.4 (1.51)	20.3 (0.80)	13.5 (0.53)	22 (0.86)	1/2-14
FF3056-1212S	37.3 (1.47)	41.9 (1.65)	31.2 (1.23)	18.3 (0.72)	32 (1.26)	3/4-14

# Adapters

## Female ORS to Female STC

STC adapters come standard with nitrile o-rings. See page 8 for seal options.

### Straight FF3236

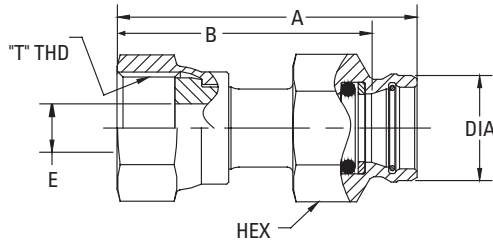

Straight Part No.	A	B	DIA	E	HEX	"T" THD
	mm (in.)	mm (in.)	mm (in.)	mm (in.)	mm (in.)	mm (in.)
FF3236-0606S	50.8 (2.00)	18.2 (0.72)	19 (0.75)	6.7 (0.26)	19 (0.75)	11/16-16 2B
FF3236-0808S	45.5 (1.79)	22.1 (0.87)	20.3 (0.80)	9.1 (0.36)	24 (0.95)	1 3/16-16 2B

### 45° FF3362

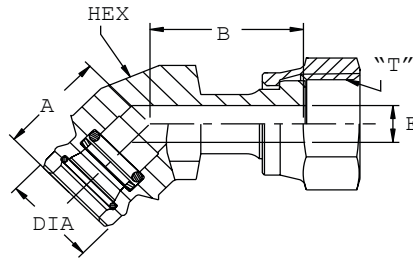

45° Part No.	A	B	DIA	E	HEX	"T" THD
	mm (in.)	mm (in.)	mm (in.)	mm (in.)	mm (in.)	mm (in.)
FF3362-0606S	18.8 (0.74)	26.9 (1.06)	17 (0.67)	6.7 (0.26)	19 (0.75)	11/16-16 2B

### 90° FF3246

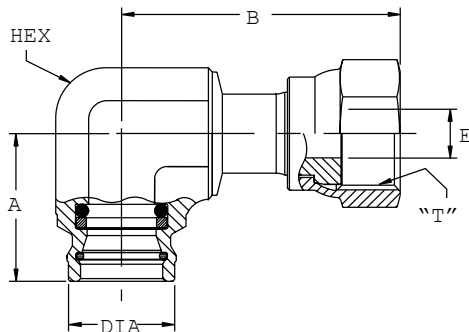

90° Part No.	A	B	DIA	E	HEX	"T" THD
	mm (in.)	mm (in.)	mm (in.)	mm (in.)	mm (in.)	mm (in.)
FF3246-0606S	27.7 (1.09)	40.6 (1.60)	16.5 (0.65)	6.7 (0.26)	19 (0.75)	11/16-16 2B
FF3246-0808S	27.5 (1.08)	51.9 (2.04)	19.8 (0.78)	9.1 (0.36)	22 (0.86)	13/16-16 2B

**Male ORS to Male STC  
Straight FF3412**

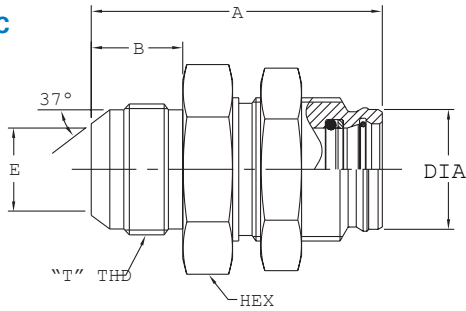

Straight Part No.	A	B	DIA	"	HEX	"T" THD
	mm (in.)	mm (in.)	mm (in.)	mm (in.)	mm (in.)	mm (in.)
FF3412-1612S	73.7 (2.90)	23.1 (0.91)	31.2 (1.23)	20.6 (0.81)	46 (1.79)	1 5/16-12 2A

**SAE 37° Male Flare to Female  
STC, Bulkhead Adapters 90°  
Elbow FF3044**

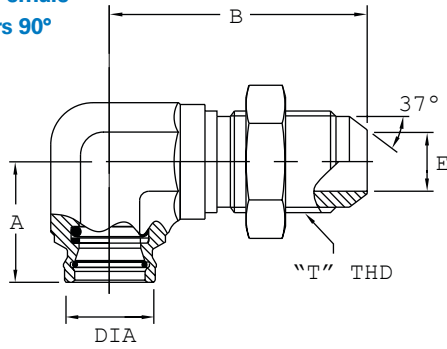

90° Part No.	A	B	DIA	E	HEX	"T" THD
	mm (in.)	mm (in.)	mm (in.)	mm (in.)	mm (in.)	mm (in.)
FF3044-1210S	31.8 (1.25)	67.8 (2.67)	24.4 (0.96)	15.5 (0.61)	27 (1.06)	1 1/16-16 2A
FF3044-1616S	46.4 (1.83)	64.5 (2.54)	41 (1.61)	21.4 (0.84)	41 (1.61)	1 5/16-12 2A

## Straight FF3061

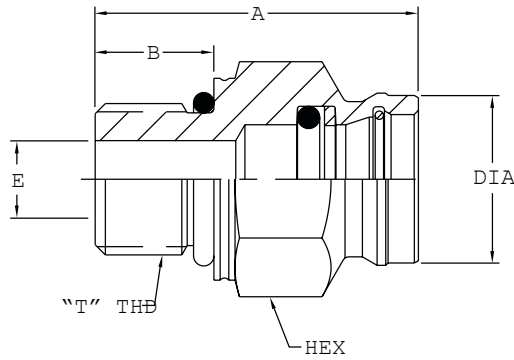

Straight Part No.	A	B	DIA	E	HEX	"T" THD
	mm (in.)	mm (in.)	mm (in.)	mm (in.)	mm (in.)	mm (in.)
FF3061-1006S	29 (1.14)	9.5 (0.37)	17 (0.67)	3.1 (0.12)	19 (0.75)	M10x1 6g
FF3061-1206S	30.5 (1.20)	11 (0.43)	17 (0.67)	4.1 (0.16)	19 (0.75)	M12x1.5 6g
FF3061-1406S	30.5 (1.20)	11 (0.43)	17 (0.67)	6.1 (0.24)	19 (0.75)	M14x1.5 6g
FF3061-1408S	34.8 (1.37)	11 (0.43)	20.3 (0.80)	6.1 (0.24)	21 (0.82)	M14x1.5 6g
FF3061-1606S	32 (1.26)	12.5 (0.49)	17 (0.67)	7.1 (0.28)	22 (0.86)	M16x1.5 6g
FF3061-1608S	36.3 (1.43)	12.5 (0.49)	20.3 (0.80)	7.1 (0.28)	22 (0.86)	M16x1.5 6g
FF3061-1610S	39.5 (1.56)	12.5 (0.49)	24.4 (0.96)	7.1 (0.28)	25 (0.98)	M16-1.5 6g
FF3061-1806S	33.5 (1.32)	14 (0.55)	17 (0.67)	9.1 (0.36)	24 (0.94)	M18-1.5 6g
FF3061-1808S	38.1 (1.50)	14 (0.55)	20.3 (0.80)	9.1 (0.36)	24 (0.94)	M18-1.5 6g
FF3061-1810S	39.4 (1.55)	14 (0.55)	24.4 (0.96)	9.1 (0.36)	25 (0.98)	M18-1.5 6g
FF3061-1812S	50 (1.97)	14 (0.55)	31.3 (1.23)	9.1 (0.36)	32 (1.26)	M18-1.5 6g
FF3061-2210S	40.4 (1.59)	15 (0.59)	24.4 (0.96)	12.1 (0.48)	27 (1.06)	M22-1.5 6g
FF3061-2212S	51 (2.01)	15 (0.59)	31.3 (1.23)	12.1 (0.48)	32 (1.26)	M22-1.5 6g

## 45° Adjustable FF3065

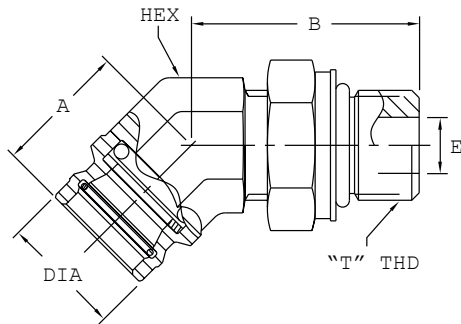

45° Part No.	A	B	DIA	E	HEX	"T" THD
	mm (in.)	mm (in.)	mm (in.)	mm (in.)	mm (in.)	mm (in.)
FF3065-1406S	18.8 (0.74)	31.4 (1.24)	17 (0.67)	6.1 (0.24)	19 (0.75)	M14-1.5 6g
FF3065-1606S	18.8 (0.74)	33.5 (1.32)	17 (0.67)	7.1 (0.28)	19 (0.75)	M16-1.5 6g
FF3065-1808S	21.6 (0.85)	37 (1.46)	20.3 (0.80)	9.1 (0.36)	22 (0.87)	M18-1.5 6g
FF3065-1810S	25.9 (1.02)	42.5 (1.67)	24.4 (0.96)	9.1 (0.36)	27 (0.05)	M18-1.5 6g
FF3065-2212S	31.2 (1.23)	44 (1.73)	31.2 (1.23)	12.1 (0.48)	32 (1.25)	M22-1.5 6g
FF3065-2712S	30.3 (1.19)	52.6 (2.07)	31 (1.21)	15.1 (0.60)	36 (1.40)	M27-2 6g

## 90° Adjustable FF3067

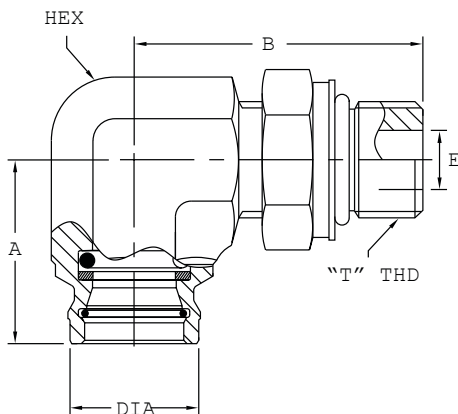

90° Part No.	A	B	DIA	E	HEX	"T" THD
	mm (in.)	mm (in.)	mm (in.)	mm (in.)	mm (in.)	mm (in.)
FF3067-1406S	24.9 (0.98)	35.5 (1.40)	17 (0.67)	6.1 (0.24)	19 (0.75)	M14-1.5 6g
FF3067-1606S	27.7 (1.09)	42.9 (1.69)	17 (0.67)	7.1 (0.28)	19 (0.75)	M16-1.5 6g
FF3067-1808S	28.2 (1.11)	44.3 (1.74)	20.3 (0.80)	9.1 (0.36)	22 (0.87)	M18-1.5 6g
FF3067-1810S	33.3 (1.31)	47.5 (1.87)	24.4 (0.96)	9.1 (0.36)	27 (1.06)	M18-1.5 6g
FF3067-2210S	33.3 (1.31)	49 (1.93)	24.4 (0.96)	12.1 (0.48)	27 (1.06)	M22-1.5 6g
FF3067-2212S	37.6 (1.48)	50.8 (2.00)	31.2 (1.23)	12.1 (0.48)	32 (1.25)	M22-1.5 6g
FF3067-2712S	37.6 (1.48)	55.5 (2.18)	31.2 (1.23)	15.1 (0.60)	32 (1.26)	M27-2 6g

# Adapters

STC adapters come standard with nitrile o-rings. See page 8 for seal options.

## O-Ring Boss DIN 3852 Metric Male to Female STC

### Straight FF3284

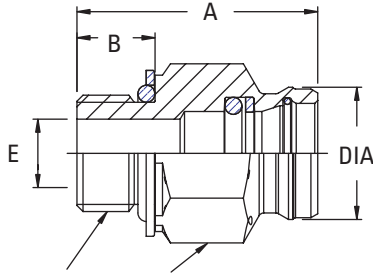

Straight Part No.	A	B	DIA	E	HEX	"T" THD
	mm (in.)	mm (in.)	mm (in.)	mm (in.)	mm (in.)	mm (in.)
FF3284-1608S	37.5 (1.48)	12.0 (0.47)	20.3 (0.80)	8.5 (0.34)	22.1 (0.88)	M18-1.5 6g
FF3284-1808S	37.0 (1.46)	12.0 (0.47)	20.3 (0.80)	10.5 (0.42)	23.8 (0.94)	M18-1.5 6g
FF3284-2612S	48.4 (1.91)	15.4 (0.61)	31.3 (1.24)	15.0 (0.60)	36.0 (1.42)	M18-1.5 6g

### 90° FF3286

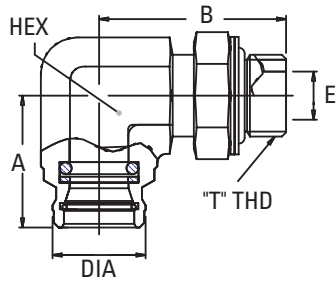

90° Part No.	A	B	DIA	E	HEX	"T" THD
	mm (in.)	mm (in.)	mm (in.)	mm (in.)	mm (in.)	mm (in.)
FF3284-1808S	28.8 (1.14)	40.8 (1.61)	20.3 (0.80)	10.5 (0.42)	22.0 (0.87)	M18-1.5 6g

# Adapters

## Male BSPT to Female STC

STC adapters come standard with nitrile o-rings. See page 8 for seal options.

### Straight FF3503

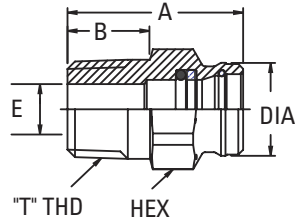

Straight Part No.	A	B	DIA	E	HEX	"T" THD
	mm (in.)	mm (in.)	mm (in.)	mm (in.)	mm (in.)	mm (in.)
FF3503-0406S	37.1 (1.47)	13.0 (0.51)	17.0 (0.67)	5.0 (0.20)	19.0 (0.75)	R <sup>1</sup> / <sub>4</sub> - 19
FF3503-0606S	36.9 (1.46)	15.0 (0.59)	17.0 (0.67)	8.0 (0.32)	19.0 (0.75)	R <sup>3</sup> / <sub>8</sub> - 19
FF3503-0808S	38.3 (1.51)	18.0 (0.71)	20.3 (0.80)	11.0 (0.43)	24.0 (0.95)	R <sup>1</sup> / <sub>2</sub> - 14
FF3503-1212S	44.7 (1.77)	20.0 (0.79)	31.3 (1.24)	16.0 (0.63)	32.0 (1.26)	R <sup>3</sup> / <sub>4</sub> - 14

### 45° FF3505

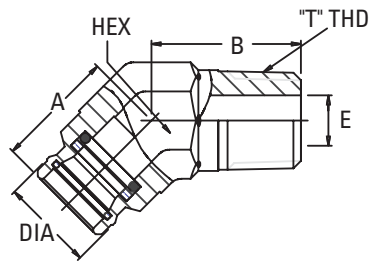

45° Part No.	A	B	DIA	E	HEX	"T" THD
	mm (in.)	mm (in.)	mm (in.)	mm (in.)	mm (in.)	mm (in.)
FF3505-0406S	18.7 (0.74)	13.0 (0.51)	17.0 (0.67)	5.0 (0.20)	19.0 (0.75)	R <sup>1</sup> / <sub>4</sub> - 19
FF3505-0606S	20.5 (0.81)	24.4 (0.96)	17.0 (0.67)	8.0 (0.32)	19.0 (0.75)	R <sup>3</sup> / <sub>8</sub> - 18
FF3505-0808S	26.2 (1.04)	34.0 (1.34)	20.3 (0.80)	11.0 (0.43)	22.0 (0.87)	R <sup>1</sup> / <sub>2</sub> - 14
FF3505-1212S	32.6 (1.29)	36.0 (1.42)	31.3 (1.24)	16.0 (0.63)	32.0 (1.26)	R <sup>3</sup> / <sub>4</sub> - 14

### 90° FF3507

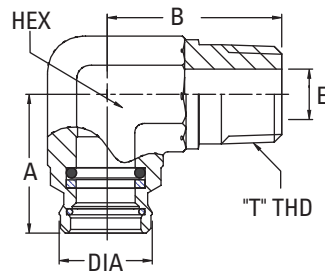

90° Part No.	A	B	DIA	E	HEX	"T" THD
	mm (in.)	mm (in.)	mm (in.)	mm (in.)	mm (in.)	mm (in.)
FF3507-0406S	28.1 (1.11)	27.5 (1.08)	17.0 (0.67)	5.0 (0.20)	19.0 (0.75)	R <sup>1</sup> / <sub>4</sub> - 19
FF3507-0606S	28.1 (1.11)	27.5 (1.08)	17.0 (0.67)	5.0 (0.20)	19.0 (0.75)	R <sup>3</sup> / <sub>8</sub> - 19
FF3507-0808S	30.3 (1.19)	38.4 (1.50)	20.3 (0.80)	11.0 (0.43)	22.0 (0.87)	R <sup>1</sup> / <sub>2</sub> - 14
FF3507-1212S	37.3 (1.47)	41.9 (1.65)	31.3 (1.24)	16.0 (0.63)	32.0 (1.26)	R <sup>3</sup> / <sub>4</sub> - 14

# Adapters

## Male BSPP (Special JIS) to Female STC

STC adapters come standard with nitrile o-rings. See page 8 for seal options.

### Straight FF3509

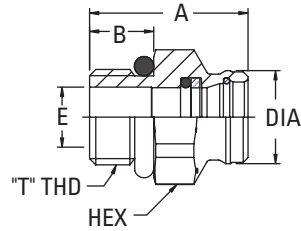

Straight Part No.	A	B	DIA	E	HEX	"T" THD
	mm (in.)	mm (in.)	mm (in.)	mm (in.)	mm (in.)	mm (in.)
FF3509-0406S	30.1 (1.19)	12.0 (0.47)	17.0 (0.67)	6.1 (0.24)	19.0 (0.75)	G <sup>1/4</sup> - 19
FF3509-0606S	28.9 (1.14)	12.0 (0.47)	17.0 (0.67)	9.6 (0.38)	22.0 (0.87)	G <sup>3/8</sup> - 19
FF3509-0808S	34.6 (1.37)	14.0 (0.55)	20.3 (0.80)	13.1 (0.52)	27 (1.07)	G <sup>1/2</sup> - 14
FF3509-1212S	47.6 (1.88)	16.0 (0.24)	31.3 (1.24)	18.1 (0.72)	32 (1.26)	G <sup>3/4</sup> - 14

### 45° FF3511

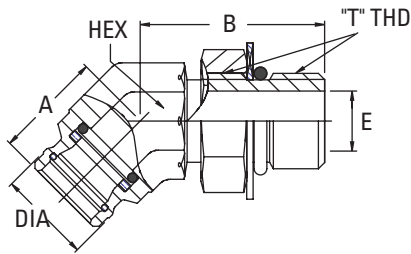

45° Part No.	A	B	DIA	E	HEX	"T" THD
	mm (in.)	mm (in.)	mm (in.)	mm (in.)	mm (in.)	mm (in.)
FF3511-0406S	16.8 (0.66)	32.4 (1.28)	17.0 (0.67)	6.1 (0.24)	19.0 (0.75)	G <sup>1/4</sup> - 19
FF3511-0606S	16.8 (0.66)	35.0 (1.38)	17.0 (0.67)	9.6 (0.38)	19.0 (0.75)	G <sup>3/8</sup> - 19
FF3511-0808S	23.6 (0.93)	40.2 (1.59)	20.3 (0.80)	13.1 (0.52)	22.0 (0.87)	G <sup>1/2</sup> - 14
FF3511-1212S	29.9 (1.18)	46.7 (1.85)	31.3 (1.24)	18.1 (0.72)	32.0 (1.26)	G <sup>3/4</sup> - 14

### 90° FF3513

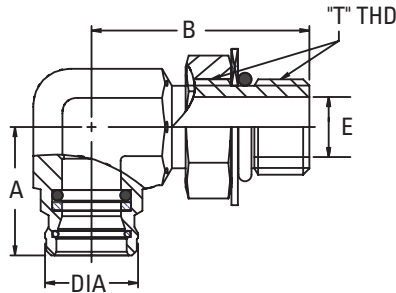

90° Part No.	A	B	DIA	E	HEX	"T" THD
	mm (in.)	mm (in.)	mm (in.)	mm (in.)	mm (in.)	mm (in.)
F3513-0406S	28.1 (1.11)	37.8 (1.49)	17.0 (0.67)	6.1 (0.24)	19.0 (0.75)	G <sup>1/4</sup> - 19
FF3513-0606S	28.1 (1.11)	39.5 (1.56)	17.0 (0.67)	9.6 (0.38)	19.0 (0.75)	G <sup>3/8</sup> - 19
FF3513-0808S	28.0 (1.11)	47.5 (1.88)	20.3 (0.80)	13.1 (0.52)	22.0 (0.87)	G <sup>1/2</sup> - 14
FF3513-1212S	38.0 (1.50)	56.4 (2.23)	31.3 (1.24)	18.1 (0.72)	32.0 (1.26)	G <sup>3/4</sup> - 14

## Straight FF3218

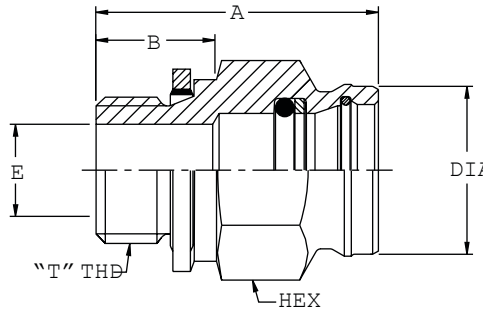

Straight Part No.	A	B	DIA	E	HEX	"T" THD
	mm (in.)	mm (in.)	mm (in.)	mm (in.)	mm (in.)	mm (in.)
FF3218-0406S	31.8 (1.25)	14.2 (0.56)	17 (0.67)	6.1 (0.24)	19 (0.75)	G6 1/4-19A
FF3218-0606S	32.3 (1.27)	14.6 (0.58)	17 (0.67)	9.6 (0.38)	22 (0.87)	G6 3/8-19A
FF3218-0806S	37 (1.46)	17.2 (0.68)	17 (0.67)	9.1 (0.36)	27 (1.06)	G6 1/2-14A
FF3218-0608S	36.1 (1.42)	14.6 (0.58)	20.3 (0.80)	9.6 (0.38)	22 (0.87)	G6 3/8-19A
FF3218-0808S	38.6 (1.52)	17.2 (0.68)	20.3 (0.80)	12.3 (0.48)	27 (1.06)	G6 1/2-14A
FF3218-0810S	40.2 (1.58)	17.2 (0.68)	24.4 (0.96)	13.1 (0.52)	27 (1.06)	G6 1/2-14A
FF3218-1210S	42.2 (1.66)	19.2 (0.75)	24.4 (0.96)	15.5 (0.61)	32 (1.26)	G6 3/4-14A
FF3218-1212S	44.2 (1.74)	19.2 (0.75)	31.2 (1.23)	18.1 (0.71)	32 (1.26)	G6 3/4-14A

## Tee Adapter Female STC FF3178

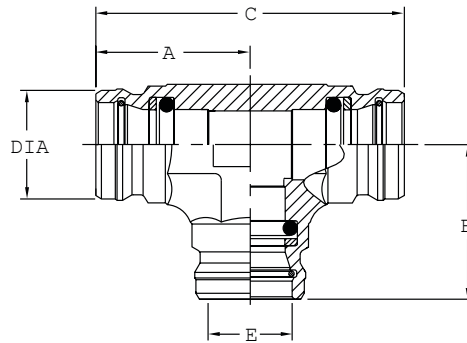

Part No.	A	B	C	DIA	E
	mm (in.)	mm (in.)	mm (in.)	mm (in.)	mm (in.)
FF3178-0808S	28.2 (1.11)	28.2 (1.11)	56.4 (2.22)	20.3 (0.80)	20.3 (0.80)

# Adapters

Repair adapters can be used to convert hose assembly with male pipe, female JIC, or female ORFS hose ends to a STC female direct port or a STC female adapter.

## Female Pipe to Male STC

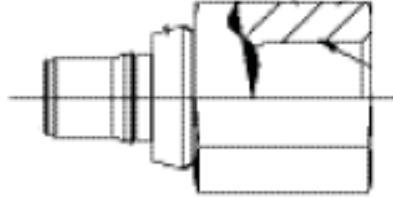

Part No.	Thread	Male STC Size
FF3233-0406S	¼"-18	-06
FF3233-0606S	3/8"-18	-06
FF3233-0808S	½"-14	-08
FF3233-0810S	½"-14	-10
FF3233-1212S	¾"-14	-12
FF3233-1616S	1"-11½	-16

## Male JIC to Male STC

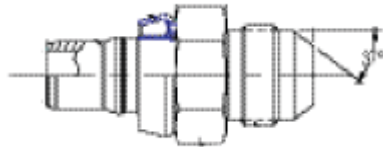

Part No.	Thread	Male STC Size
FF3227-0406S	7/16"-20	-06
FF3227-0606S	9/16"-18	-06
FF3227-0808S	¾"-16	-08
FF3227-1010S	7/8"-14	-10
FF3227-1212S	1 1/16"-12	-12
FF3227-1616S	1 5/16"-16	-16

## Male ORFS to Male STC

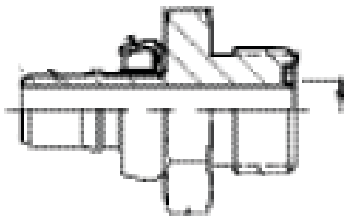

Part No.	Thread	Male STC Size
FF3318T0406-458	9/16"-18	-06
FF3318T0606-458	11/16"-16	-06
FF3318T0808-458	13/16"-16	-08
FF3318T1010-458	1"-14	-10
FF3318T1212-458	1 3/16"-12	-12
FF3318T1616-458	1 7/16"-12	-16

# Adapters

## Braze Female STC Adapters

Female STC Braze Spud adapters are available. To attach these carbon steel braze spuds to a carbon steel surface, the following brazing techniques can be used:

1. Silver Brazing
2. Copper Brazing

- Braze spuds can be attached by the end user
- Alternative to direct porting for smaller production runs
- Offered in straight configurations
- Can be used with standard male STC fittings

Size	Pressure Rating (PSI)
-06	5,000
-08	4,250
-10	3,750
-12	3,750
-16	2,500

**Note:**  
Post brazing coatings that exceed 0.0004" thickness require masking of inside of the female connector to prevent interferences with mating components. Industrial platings are generally acceptable, but paintings will probably require maskings.

Please contact Eaton for product availability.

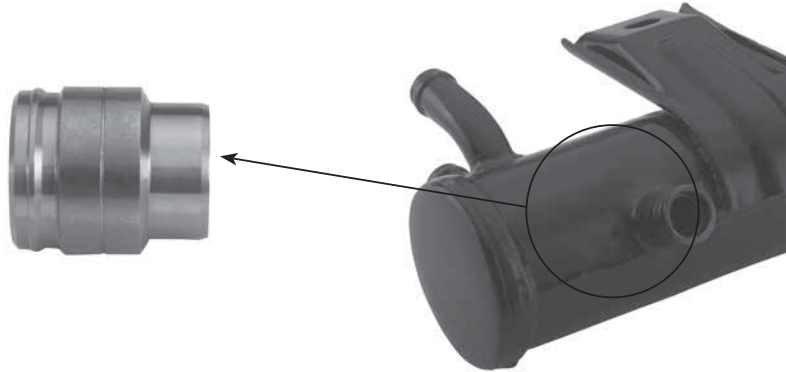

# Press Fit Adapters

## Eaton Offers a Lower Pressure STC Adapter Solution



Press fit “barbed” STC female adapters can be pressed into SAE counterbores in softer materials such as aluminum.

### Advantages

- Offers threadless adapter technology – there are no torque requirements and no cross-threading
- Offers an alternative solution to direct porting STC into aluminum castings
- Adapter design contains an elastomeric seal to provide virtually leak-free performance
- Fits in confined spaces that a threaded connection wouldn’t
  - threaded connection limits how close ports can be to each other due to wrench or socket clearance
  - press fit adapters have no hex points
- Can be used with all male STC fittings
- Maximum operating pressure is 500 psi for sizes -8 and -10

# Press Fit Adapters

Female STC

## Straight FF3113

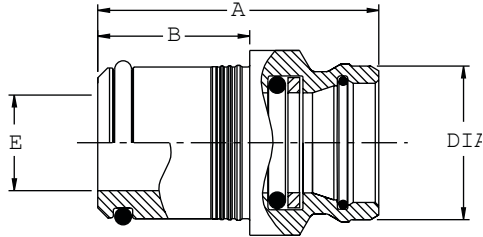

### Straight

Part No.	A	B	DIA	E
	mm (in.)	mm (in.)	mm (in.)	mm (in.)
FF3113-02-0808S	36.2 (1.42)	19.6 (0.77)	20.3 (0.80)	12.3 (0.48)

## 45° FF3162

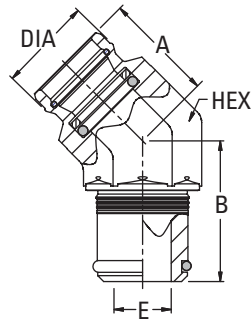

### 45°

Part No.	A	B	DIA	E	HEX
	mm (in.)	mm (in.)	mm (in.)	mm (in.)	mm (in.)
FF3162-0808S	24.1 (0.95)	30.2 (1.19)	20.3 (0.80)	12.3 (0.49)	22.0 (0.87)

## 90° FF3115

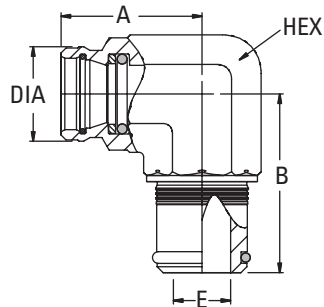

### 90°

Part No.	A	B	DIA	E	HEX
	mm (in.)	mm (in.)	mm (in.)	mm (in.)	mm (in.)
FF3115-0808S	30.3 (1.20)	38.4 (1.52)	20.3 (0.80)	12.3 (0.49)	22.0 (0.87)
FF3115-1010S	33.5 (1.32)	40.9 (1.62)	24.4 (0.96)	15.5 (0.61)	27.0 (1.07)

# Press-Fit Adapter Installation Instructions

## Assembly Steps

The following sequence of should be followed when assembling the press-fit adapter into the port.

**Improper assembly of these adapters may result in leakage or adapter coming out of the port once pressurized. Serious personal injury or death may result in the event the adapter comes out of the port after pressurization.**

### 1. Lubricate o-ring

Thoroughly apply DC200 or equivalent silicon based lubricant to the o-ring so that it is visibly wet to touch.

### 2. Hand Install Adapter

Insert the press-fit adapter into the port until the first rib of the adapter makes contact with the port ID. Solid resistance will be felt. Note that a shaped adapter (45° or 90° configuration) should now be rotated to its

proper orientation toward the direction of the hose connection for ease of assembly.

### 3. Press Operation

The press-fit adapter should be finally be inserted completely into the port by some means of a press. The pressing action should supply a force along the centerline of the press-fit adapter end and mating port. Shaped adapters will

require holding tools designed for pressing the adapter into the port without damage to the adapter. Note that rotation of shaped adapters is not permitted after the press operation.

### 4. Inspection

The shoulder of press-fit adapter should be flush with the face of the port. **Adapters should not be removed after assembly and reused.**

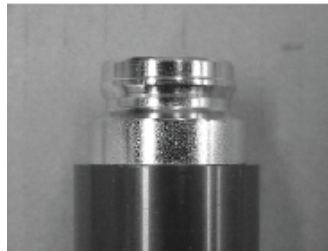

# Direct Port STC Connections

Eaton female STC connectors can be direct ported into valves, pump housings, motor cases, etc. Direct porting increases the value of STC connections compared to threaded connections by:

- Eliminating the need for adapters; the hose fitting connects directly into the casting
- Offering fewer leak paths
- Offering higher pressure capability compared to STC adapters

## Applications Include:

- Power Steering Valves
- Hydraulic Pumps/Motors
- Joysticks
- Control Valves
- Oil Coolers
- Oil Filter Heads
- Engine Blocks

*Contact Eaton for details relating to design and licensing questions.*

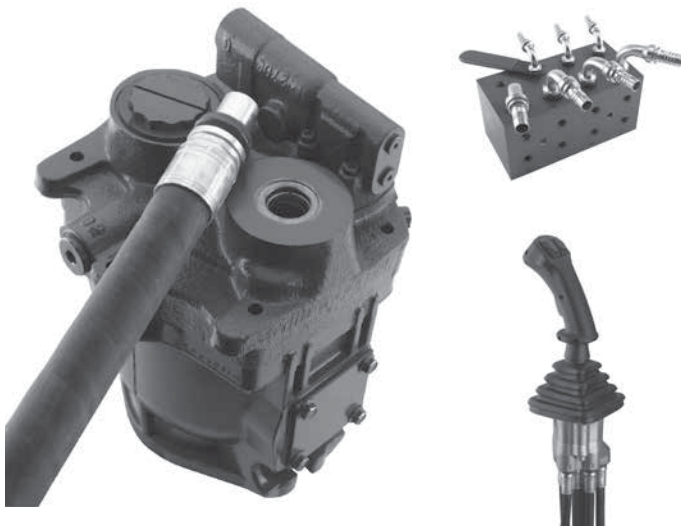

### Sample Impluse Test Results - Aluminum

Size	Pressure	Material	Cycles
-6	3,500 psi	6061T651	1 million
-8	3,500 psi	6061T651	1 million
-10	3,500 psi	6061T651	1 million
-12	3,500 psi	6061T651	1 million
-6	3,500 psi	2024T351	1 million
-8	3,500 psi	2024T351	1 million
-10	3,500 psi	2024T351	1 million
-12	3,500 psi	2024T351	1 million

### Sample Impluse Test Results

Size	Pressure	Material	Cycles
-8	6,000 psi	65-45-12	2 million
-10	5,000 psi	Class 35	1.5 million
-12	6,500 psi	Class 40	2 million
-12	6,000 psi	80-55-06	1 million

\*Performance is based on thickness/geometry of material.

# Direct Port STC Connections

## STC with Adapters

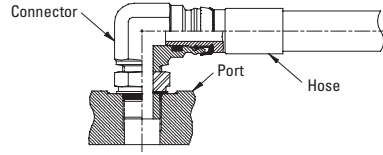

## STC with Direct Port

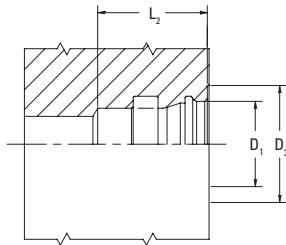
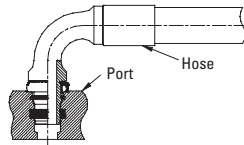

### STC Direct

#### Port Dimensions

STC Size	D1 mm	D3 mm	L2 (Minimum) mm
-06	11.4	18.3	15.2
-08	15.3	21.5	19.5
-10	18.7	25.5	22.3
-12	23.2	32.3	26.6
-16	29.2	41.0	31.8

## Female Ring Insertion Tools (For Female Ports)



### Pneumatic Insertion Tool\*

Size	Part Number
-06	FT1362-06
-08	FT1362-08
-10	FT1362-10
-12	FT1362-12

### Retaining Ring Insertion Tool

Size	Part Number
-06	FT1363-06
-08	FT1363-08
-10	FT1363-10
-12	FT1363-12

### Retaining Ring Test Tool

Size	Part Number
-06	FT1364-06
-08	FT1364-08
-10	FT1364-10
-12	FT1364-12

\* For -16 sizes please contact Eaton.

# Female Ring Insertion Tools

## STC O-ring/Backup Ring Insertion Tool-FT1362

### Getting Started

For longest tool life, it is recommended to operate the tool at the lowest pressure to do the job. The tool has a **maximum air pressure** of 100 psi.

**Tool must be lubricated;** either with an in-line oiler located no more than 6ft. from the tool or oiled directly through the rear of the power pack with several drops of good hydraulic oil weekly.

Insertion tool must be cleaned and foreign material removed weekly or more often if necessary. Always wear eye and ear protection when operating this tool.

### Operating Instructions

1. Hold the unit in either hand as shown in Figure 1. Place the tool in the palm of the hand with the thumb comfortably resting on the actuation lever. The tool is designed for both left and right handed operation.
2. Place o-ring and backup ring together in the groove with the free hand and gently squeeze at the side to secure in place (Figure 2). The o-ring must be on the side caught by the hook loop.
3. While still holding the o-ring and backup ring, press the actuation lever

to retract the hook and load the components (Figure 3). If one or both of the components does not load properly, release the actuator, discard the components and try again with new components.

**⚠ Caution:**  
Never Place Fingers On The Tool Hook Or In Its Path While The Tool Is Plugged Into An Air Supply! Personal Injury Can Occur!

4. Insert the loaded device into the part to be assembled (Figure 4). The face of the tool must be held firmly to the part being assembled.

5. While holding firmly in place, release the actuation lever of the tool.
6. Gently pull the device from the part. If the device resists, then twist the tool gently while pulling.
7. Inspect part to see that components were installed properly and that the o-ring and back-up ring were not damaged or deformed during the process (Figure 5). Repeat steps 1-7 for additional assemblies.

**⚠ Caution:**  
Tooling Under Pressure!  
Always Disconnect Air Supply Before Working On Tool.  
Personal Injury Can Occur!



Figure 1 – Holding the Insertion Tool



Figure 2 – Squeezing the O-ring & Back-up ring

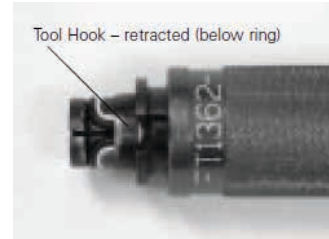

Figure 3 – O-ring & Back-up ring Loaded Into Tool

# Female Ring Insertion Tools

## Replacing The Hook

1. Unthread the adapter (Item 3) counterclockwise and pull off part. Be sure that the pusher (Item 4) does not fall out.
2. Slide the pusher off the collar (Item 2).
3. Use a straight-shafted devic to press the roll pin (Item 5) out of the pusher.
4. Pull the hook (Item 6) from the bottom of the pusher.
5. Insert the new hook.
6. Gently press the roll pin in so that it is centered in the pusher
7. Place the pusher back onto the collar.
8. Align the pusher assembly with the channel adapter and thread the adapter back on to the pneumatic actuator.

## Troubleshooting

### Hook will not retract when you push the lever.

- Check the air pressure
- The internal slide assembly may be gummed up. Take apart as outlined in the "Replacing The Hook" section and clean with a solvent.

### Tool is difficult to remove after inserting components.

- Are the components being installed in the correct orientation? The o-ring should be on the bottom and the backup ring on the top when looking down into the finished part (Figure 6).

**Is the hook cutting or tearing the components? It may need replacing. If the backup ring is not going all the way into the gland, the pusher may need to be cleaned or replaced. Check to see that when the components are**

**loaded and the tool is retracted (Figure 3) that the backup ring is behind the o-ring and not underneath it at the tip of the hook. If this is the case then:**

- Do you have the right components?
- Make sure that when you are loading it that you are squeezing the o-ring and backup ring sufficiently.
- Check to see if the hook is damaged or broken. If so then replace the hook.

**The channel location is out of alignment.**

- Loosen the adapter by hand (Item 3) by turning it counterclockwise approximately 1/4 turn.
- Turn the channel to the desired location.
- Hand-tighten the Adapter Clockwise.



Figure 4 – Place The Tool Inside The Part



Figure 5 – Properly Assembled O-ring & Back-up ring

# Female Ring Insertion Tools

## STC Retaining Ring Insertion Tool-FT1363

### Getting Started

Insert the holding bar, #FT1363-01-SIZE, into the handle grips, #FT1363-03, as shown in (Figure 1).

Insert the tool head, #FT1363-02-SIZE, into the holding bar, as shown in (Figure 2), and tighten socket set screw.



Figure 1



Figure 2

### Operating Instructions

1. Hold the unit in either hand as shown in (Figure 3).
2. Place the retaining ring on top of the part as shown in (Figure 4).
3. Insert the end of the tool head over top of the retaining ring as shown in (Figure 5).
4. Rotate the tool in a circular motion while applying a downward force and pivoting around the retaining ring as shown in (Figure 6).
5. Once the retaining ring has snapped into the appropriate groove, remove tool from part.
6. Inspect part to ensure that retaining ring was installed properly as shown in (Figure 7). Repeat steps 1-6 for additional assemblies.



Figure 3



Figure 4



Figure 5



Figure 6



Figure 7

# Female Ring Insertion Tools

## STC Retaining Ring Test Tool—FT1364

### Getting Started

For longest tool life it is recommended to operate the tool at the lowest pressure to do the job. The tool has a **maximum pair pressure** of 100 psi.

**Tool must be lubricated;** either with an in-line oiler located no more than 6ft. from the tool or oiled directly through the rear of the power pack with several drops of good hydraulic oil weekly.

Insertion tool must be cleaned and foreign material removed weekly or more often if necessary.

Always wear eye and ear protection when operating this tool.

### Operating Instructions

1. Hold the latch test tooling in either hand as shown in (Figure 1).
2. Load male end of latch test tooling into female end of part (Figure 2).
3. Press and hold the actuation lever to perform the test.
4. While holding the actuation lever, try to separate the part and

the latch test tooling to ensure the latch has been installed properly

- If latch fails, remove part and release actuation lever. Skip to Step 9.
  - If latch test passes, release the actuation lever.
5. Turn the outer aluminum casing as far clockwise as

possible (Figure 3).

6. Press and hold the actuation lever and pull latch test tooling from part.
7. Release the actuation lever and the outer aluminum casing, allowing it to return to the original position. Repeat steps 1-7 for additional latch tests.



Figure 1 – Holding Tool



Figure 2 – Loading Tool Into Part



Figure 3 – Twisting Tool To Release

### ⚠ Caution:

Tooling Under Pressure! Always Disconnect Air Supply Before Working On Tool. Personal Injury Can Occur!

### Troubleshooting

Mandrel will not retract when you push the actuation lever.

- Check the pressure.
- The internal assembly may be gummed up. Take apart and clean with a solvent. Then reassemble tooling

as outlined in the ASSEMBLY INSTRUCTIONS.

Tool is difficult to remove after testing the component.

- While holding the actuation lever to release the part, push the latch test tooling

further into the part and then pull the tester out from the part.

Outer aluminum casing does not return to original position after turning clockwise.

- Spring(s) may be damaged.

Disassemble tool and examine springs. Replace damaged spring(s).

- Tool may be damaged or worn. Inspect tool for damage and replace part as necessary.

# Accessories and Sales Tools

## Release Tools

- STC -04 = FF90213-01-04S
- STC -06 = FF90213-06
- STC -08 = FF90213-08
- STC -10 = FF90213-10
- STC -12 = FF90213-12
- STC -16 = FF90213-01-16S



## STC Repair Kits (Female Halves)

### Includes

- Back-up Ring
- Latch Ring
- O-Ring

### BUNA-N/NITRILE

Size	Part Number
-06	FF12228-06
-08	FF12228-08
-10	FF12228-10
-12	FF12228-12
-16	FF12228-16

### Viton

Size	Part Number
-06	FF12230-06
-08	FF12230-08
-10	FF12230-10
-12	FF12230-12
-16	FF12230-16

### HNBR

Size	Part Number
-06	FF12229-06
-08	FF12229-08
-10	FF12229-10
-12	FF12229-12
-16	FF12229-16

### EPDM

Size	Part Number
-06	FF12231-06
-08	FF12231-08
-10	FF12231-10
-12	FF12231-12
-16	FF12231-16

## Female Ring Part Numbers

### Latch Rings

Size	Part Number
-06	FF90277-06C
-08	FF90277-08C
-10	FF90277-10C
-12	FF90277-12C
-16	FF90277-16C

### Nitrile O-Rings

Size	Part Number
-06	22550-12
-08	22550-112
-10	22550-114
-12	22550-117
-16	22550-215

## STC Sales Kit

Part number FF12389-10



### Back-Up Rings

Size	Part Number
-06	FF90241-12
-08	FF90241-112
-10	FF90241-114
-12	FF90241-117
-16	FF90241-215

### HNBR O-Rings

Size	Part Number
-06	FF90467-12
-08	FF90467-112
-10	FF90467-114
-12	FF90467-117
-16	FF90467-215

### Viton O-Rings

Size	Part Number
-06	22556-12
-08	22556-112
-10	22556-114
-12	22556-117
-16	22556-215

### Note:

Female STC in the -04 size is not field repairable.

Eaton  
Hydraulics Group USA  
14615 Lone Oak Road  
Eden Prairie, MN 55344  
USA  
Tel: 952-937-9800  
Fax: 952-294-7722  
[www.eaton.com/hydraulics](http://www.eaton.com/hydraulics)

Eaton  
Hydraulics Group Europe  
Route de la Longeraie 7  
1110 Morges  
Switzerland  
Tel: +41 (0) 21 811 4600  
Fax: +41 (0) 21 811 4601

Eaton  
Hydraulics Group Asia Pacific  
Eaton Building  
No.7 Lane 280 Linhong Road  
Changning District,  
Shanghai 200335  
China  
Tel: (+86 21) 5200 0099  
Fax: (+86 21) 2230 7240