

**Eaton® FLOCS™**  
Fast Lube Oil Change System Catalog



*Powering Business Worldwide*



**EATON**

*Powering Business Worldwide*

# The Power of One Eaton

Celebrating  
**100** YEARS  
Ideals that Endure

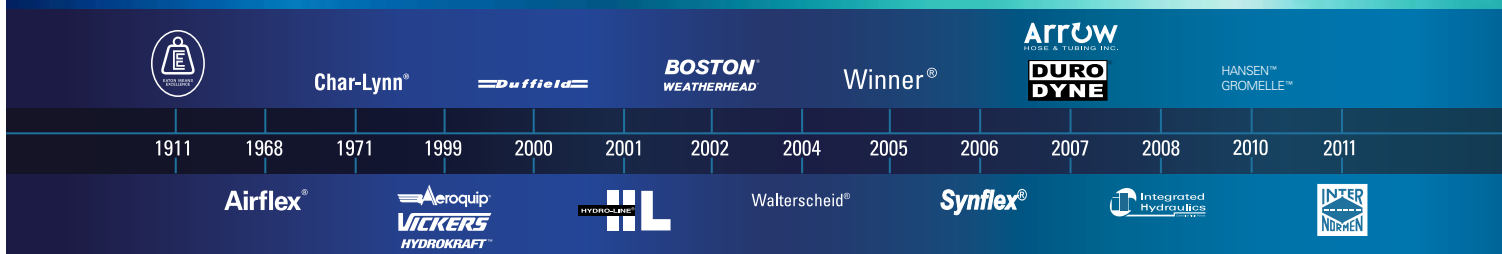

**EATON**  
*Powering Business Worldwide*

There's a certain energy at Eaton. It's the power of integrating the competencies of some of the world's most respected names to build a brand you can trust to meet every power management need. The energy created supports our commitment to powering business worldwide.

As the world's demand for high-efficiency hydraulic systems for mobile and stationary applications increase, Eaton is helping to solve these challenges more reliably, efficiently, and sustainably. Our goal is simple; to provide unique solutions across a wide range of markets that keep businesses on the leading edge of change. Visit [Eaton.com/hydraulics/fusion](http://Eaton.com/hydraulics/fusion).

**That's the power of One Eaton.**

# Serving eight key segments - sharing one focus



## Alternative Energy

Making energy sources technically practical and economically sound requires the kind of control made possible by high-quality components. When Eaton is on the inside, you will experience the reliable, consistent performance to create and capture energy—making renewable energy an every-day energy.



## Discrete Manufacturing

Produce at peak efficiency with the superior precision and repeatability of Eaton products. Eaton hydraulic components provide the precise control and consistent operation required for virtually every step in your manufacturing operation. With Eaton, we'll help you redefine the meaning of raw productivity.



## Oil & Gas

As the oil & gas industry continues to face further globalization and consolidation, large-scale organizations that can meet your needs in every corner of the world are more difficult to find. At Eaton, our portfolio of products is only surpassed by our tremendous reach.



## Processing

Whatever your industry, no matter which processes you manage, Eaton parts and systems help keep you up and running. Our components make equipment more efficient and easier to use, so you get optimal machine performance and maximum productivity.



## Agriculture & Forestry

There's a reason farming and forestry are called "working the land." These segments involve some of the hardest work and longest hours of any sector in the economy. Your productivity and profitability depend on the way you manage time and tasks.



## Commercial Vehicles

Eaton technologies can make your driving operation more successful. Greater comfort and productivity help increase driver retention, while reduced emissions, leaks, and noise improve environmental performance. Increased efficiencies overall mean lower costs and higher net revenue.



## Material Handling

Eaton hydraulic systems provide the precise control and consistent operation required for material handling and utility work. With a broad selection of products and solutions built in, Eaton helps make you a master of your domain.



## Construction & Mining

When you work on a large scale, even the details are big. You need to trust every part of the equipment that lets you handle construction and mining jobs. For reliable components that deliver consistent performance in extreme conditions, turn to Eaton.

# Eaton is a leading diversified power management company

Eaton provides reliable, efficient and safe power management for a growing number of industries.

### Understanding and helping our customers succeed

- Listening and understanding to requirements and business drivers
- Delivering solutions with value propositions to solve the critical business needs

### Knowing what's important to our customers and integrating that knowledge into the fabric of our business

- ...to deliver innovative, quality products
- ...to respond fast
- ...to provide dedicated customer service and support around the globe

### Our strength is global reach with local responsiveness and support

- Customers served in more than 150 countries
- Diverse channels ensure reliable availability and support
- Design and engineering teams provide support for standard products and custom solutions
- Eaton experts offer efficient product and application training

# Table of Contents

Access Methods .....	5
FD14 Drain Couplings.....	6
Evacuation Systems .....	8
Remote Access Conversion Kits.....	9
Oil Thief System.....	11
Remote Access Conversion Kit Installation .....	12
Air Units.....	14
Electric Units .....	17

# Access Methods

## Remote Access

The FLOCS Remote Access Conversion Kit replaces the old drain plug with a 90 degree pan adapter, hose assembly and quick-disconnect coupling.

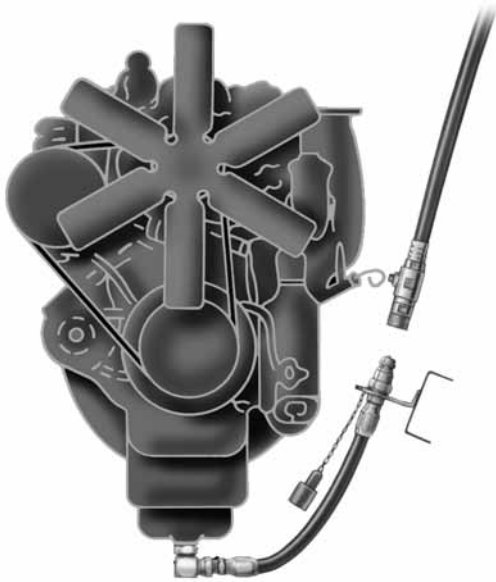

### Installation:

1. Remove old drain plug.
2. Replace with the proper size FF1187 pan adapter.
3. Install mounting bracket (and optional 90° adapter).
4. Attach hose assembly to FF1187 pan adapter and mounting bracket.
5. Attach coupling and dust cap.

Your installation is now complete.

### Evacuation:

When it is time to change the oil:

1. Remove the dust cap.
2. Connect the evacuation hose to the quick-disconnect coupling.
3. Activate the pump, and the used oil is quickly evacuated to storage tanks.
4. Disconnect the evacuation hose and replace the dust cap.

## Direct Access

The FLOCS Direct Access Conversion Kit uses the Eaton-developed FD14 Drain Coupling as an alternative to the standard remote hose kit. This coupling design permits easy, one-hand connection and disconnection of the evacuation unit's hose.

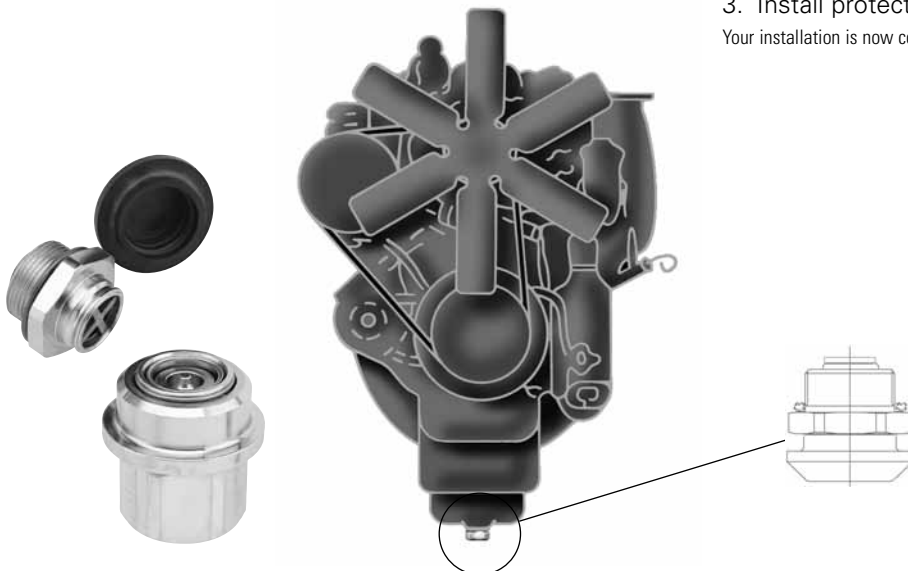

### Installation:

1. Remove old drain plug.
2. Replace with the proper size FD14 Drain Coupling.
3. Install protective cap.

Your installation is now complete.

### Evacuation:

When it is time to change the oil:

1. Remove the protective cap.
2. Connect the evacuation hose to the FD14 Drain Coupling.
3. Activate the pump, and the used oil is quickly evacuated to storage tanks.
4. Disconnect the evacuation hose and replace the protective cap.

# FD14 Drain Couplings

## Male Half Ass'y

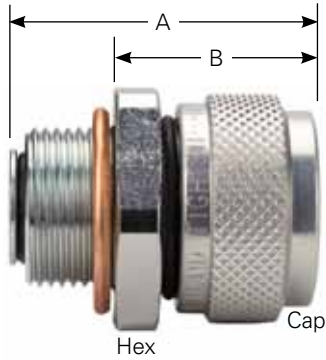

## The Newest, most direct approach to saving time and money.

Providing direct access for fast oil changes.

The FLOCS Direct Access Conversion Kit uses Full-Flow FD14 Drain Coupling as an alternative to the standard remote hose kit. This coupling design permits easy, one-hand connection and disconnection of the drain hose or the evacuation unit's hose.

- Saves time and labor costs
- Minimizes messy spills
- Able to change oil when it's hot
- One-hand connect/disconnect
- Full-flow male half coupling can be used with gravity drain or pump system
- Eliminates damaged or cross-threaded plugs

Coupling Size	Thread Size (P)	A	B		Min. Ass'y Torque (Ft.-lbs.)	Assembly† (Includes Gasket & Cap)	Gasket (Copper-Crush)	Cap (Brass)
-06	1/2 - 20 UNF - 2A	1.52	.96	1 1/16	20-24*	FD14-4002-01-06**	FD14-1206-01	FD14-1210-06
-06	M18 x 1.5 6g	1.52	.96	1 1/4	20-40*	FD14-4002-02-06**	FD14-1206-04	FD14-1210-06
-06	M14 x 1.25 6g	1.52	.96	1 1/16	20-24*	FD14-4002-03-06**	FD14-1206-02	FD14-1210-06
-06	1 1/4 - 18 UNEF - 2A	1.54	.96	1 1/2	30-60*	FD14-4002-05-06††	FD14-1206-11	FD14-1210-06
-06	1 -18 UNS - 2A	1.54	.96	1 1/4	30-60*	FD14-4002-06-06††	FD14-1206-07	FD14-1210-06
-06	7/8 - 18 UNS - 2A	1.54	.96	1 1/4	30-60*	FD14-4002-07-06††	FD14-1206-06	FD14-1210-06
-06	5/8 - 18 UNF - 2A	1.52	.96	1 1/16	20-40*	FD14-4002-08-06**	FD14-1206-03	FD14-1210-06
-06	3/4 - 16 UNF - 2A	1.54	.96	1 1/4	30-50*	FD14-4002-09-06††	FD14-1206-04	FD14-1210-06
-06	7/8 - 14 UNF - 2A	1.54	.96	1 1/4	30-60*	FD14-4002-10-06††	FD14-1206-06	FD14-1210-06
-06	M24 x 2 6g	1.54	.96	1 1/4	30-60*	FD14-4002-11-06††	FD14-1206-07	FD14-1210-06
-06	9/16 - 18 UNF - 2A	1.52	.96	1 1/16	20-40*	FD14-4002-12-06**	FD14-1206-02	FD14-1210-06
-06	1 1/8 - 12 UNF - 2A	1.54	.96	1 1/2	30-60*	FD14-4002-14-06††	FD14-1206-09	FD14-1210-06
-06	M20 x 1.5 6g	1.54	.96	1 1/4	30-60*	FD14-4002-16-06††	FD14-1206-05	FD14-1210-06
-06	M25 x 1.5 6g	1.54	.96	1 1/4	30-60*	FD14-4002-17-06††	FD14-1206-07	FD14-1210-06
-06	M22 x 1.5 6g	1.54	.96	1 1/4	30-60*	FD14-4002-18-06††	FD14-1206-06	FD14-1210-06
-06	M24 x 1.5 6g	1.54	.96	1 1/4	30-60*	FD14-4002-19-06††	FD14-1206-07	FD14-1210-06
-06	1 1/16 - 12 UN - 2A	1.54	.96	1 1/2	30-60*	FD14-4002-20-06††	FD14-1206-08	FD14-1210-06
-06	M30 x 1.5 6g	1.54	.96	1 1/2	30-60*	FD14-4002-21-06††	FD14-1206-10	FD14-1210-06
-06	1/2 - 14 UNS - 2A	1.52	.96	1 1/16	20-24*	FD14-4002-22-06**	FD14-1206-01	FD14-1210-06
-06	M12 x 1.5 6g	1.52	.96	1 1/16	20-24*	FD14-4002-23-06**	FD14-1206-01	FD14-1210-06
-06	M14 x 1.5 6g	1.52	.96	1 1/16	20-24*	FD14-4002-23-06**	FD14-1206-02	FD14-1210-06
-06	M12 x 1.75 6g	1.52	.96	1 1/16	20-24*	FD14-4002-25-06**	FD14-1206-01	FD14-1210-06
-06	3/4 - 14 Dryseal NPTF	1.69	.96	1 1/4		FD14-4002-26-06††	None Needed	FD14-1210-06
-06	1/2 - 14 Dryseal NPTF	1.60	.96	1 1/16		FD14-4002-27-06**	None Needed	FD14-1210-06
-06	M27 x 2 6g	1.54	.96	1 1/2	30-60*	FD14-4002-29-06††	FD14-1206-09	FD14-1210-06

\* CAUTION: Failure to meet minimum assembly torque could result in fluid leakage.

\*\* Approximately 0.24 GPM.

† FD14 with rubber cap can be ordered using FD14-1002-size part numbering.

†† Approximately 0.68 GPM

# FD14 Drain Couplings

## Female Half Ass'y Non Valved

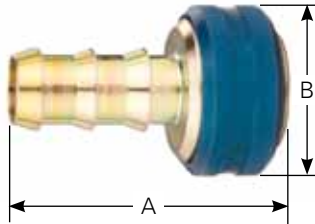

Coupling Size	A	B	THD Size (P)	Assembly
-06	2.34	1.50	5/8	FD14-4003-10-06
Socketless™				

## Cap

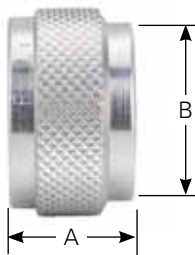

Coupling Size	A	B	Assembly
-06	0.726	1.25	FD14-1210-06

## Female Half F-NPTF Valved



Coupling Size	A	B	THD (P)	Assembly
-06	1.83	1.81	3/4-14	1-5/16 FD14-1001-12-06
Dryseal NPTF				

## Swivel Joint



Coupling Size	THD Size (P)	Assembly
-06	3/4-14	FD14-1004-2-12
Dryseal NPTF		

## Cap Molded Rubber

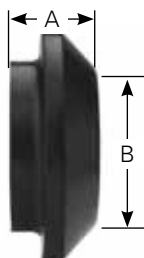

Coupling Size	A	B	Cap (BUNA-N)
-06	0.519	1.400	FD14-1204-06
Dryseal NPTF			

# Evacuation Systems

## FLOCS 30A Air-powered Unit

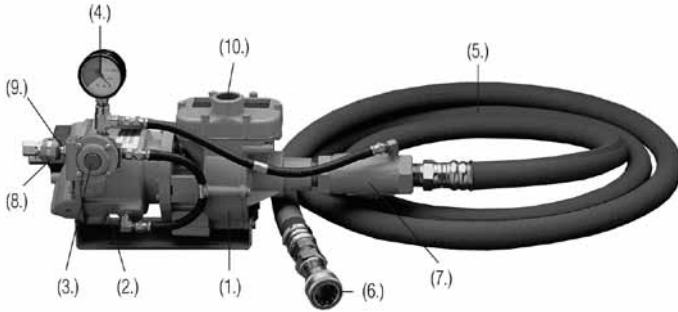

- |  |                             |
|--|-----------------------------|
| 1. Piston pump                           | 6. Coupling half**          |
| 2. 5 cfm air-operated motor (80-150 psi) | 7. Suction strainer         |
| 3. Override button                       | 8. 1/4" air-supply coupling |
| 4. Cycle gauge                           | 9. 1/4" air-supply nipple   |
| 5. 15' of 1" I.D. suction hose*          | 10. 1" NPT discharge port   |

### (Part No. FF9330A-01) Remote Access (Part No. FF9330A-19) Direct Access

The FLOCS 30A Oil-evacuation Unit is a versatile, air-powered unit designed to be used where an air-power source is available, and electrical units may present a fire hazard. The unit can be adapted for use either on a lube truck or in a maintenance bay.

A FLOCS 30A unit can be used with equal effectiveness on vehicles with small oil-pan capacities (taxicabs, delivery trucks, school buses, etc.), medium capacities (highway equipment, tree-harvesting equipment, etc.) or large capacities (mining or construction equipment, etc.). Speed, ease of operation and versatility make the FLOCS 30A the best rapid oil-evacuation unit for many applications.

\* FLOCS 30A Oil-evacuation Unit with 25' hose assembly is ordered by part number FF9330A-100 (Remote Access), FF9330A-20 (Direct Access).

\*\* Differs with access method.

## FLOCS 15 Electric-powered Unit

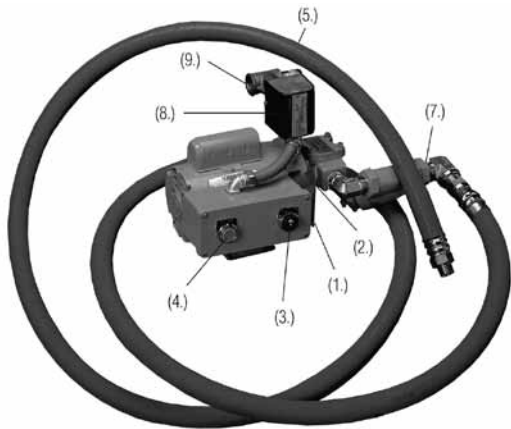

- |  |  |
|--|--|
| 1. 3/4" hp electric motor, 115V AC, 20 amp | 6. Coupling half**                                     |
| 2. Gear pump                               | 7. Suction strainer                                    |
| 3. Cycle-run starter button                | 8. 115V AC flow-control switch                         |
| 4. Cycle-run signal light                  | 9. Backflow check valve with a 3/4" NPT discharge port |
| 5. 15' of 1" I.D. suction hose*            |  |

### (Part No. FF9315-01) Remote Access (Part No. FF9315-28) Direct Access

The FLOCS 15 Oil-evacuation Unit is electric powered and is designed for use in fleet maintenance service bays. Used in conjunction with overhead oil-dispensing reels, the FLOCS 15 speeds oil changes in large fleets. In some multilane maintenance shops, the FLOCS 15 concept has been used to implement a "fast-lane" operation, with one lane set aside for high-frequency, routine maintenance functions, leaving the other lanes free for more complex and time-consuming operations.

The FLOCS 15 is compatible with existing oil service equipment and can be installed quickly, without interrupting normal maintenance operations. It discharges old oil into existing storage tanks and shuts off automatically when the old oil has been evacuated. A signal light goes off when the evacuation is complete.

\* FLOCS 15 Oil-evacuation Unit with 30' hose assembly is ordered by part number FF9516-01 (Remote Access), FF9516-02 (Direct Access).

\*\* Differs with access method.

# Remote Access (Aeroquip®) Conversion Kits

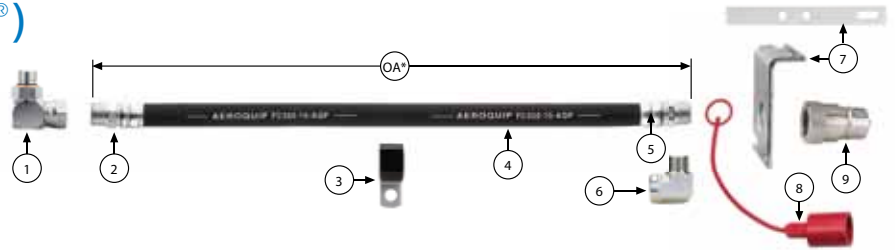

## Standard Vehicles

All kits are designed to accommodate manual drain when necessary.

**These components are common to each kit regardless of the part number.**

Item #	Part #	Description
Item # 2	4412-8-10S	Hose Fitting (Reusable)
Item # 2	FJ3152-0810S	Hose Fitting (Crimp)
Item # 3	900729-6	Hose Clamp
Item # 4	FC350-10	Hose
Item # 5	4412-12-10S	Hose Fitting (Reusable)
Item # 5	FJ3152-1210S	Hose Fitting (Crimp)
Item # 6	2089-12-12S	Connection At Mounting Flange
Item # 7	FF9363-01S	Bracket
Item # 8	5657-12	Dust Cap
Item # 9	5602-12-12S	Coupling Half

**Kit Numbers are selected by matching the drain port thread size with the oil pan adapter of the same thread.**

Thread Size	#1 Oil Pan Adapter & Gasket	Hardware Kit (Includes Items 1, 3, 6, 7, 8, & 9)	Assembled Kit* (Includes Items 1 through 9)
1/2 - 20	FF1187-0801S	FF428	FF400-OA
m 18 x 1.5	FF1187-0802S	FF429	FF401-OA
m 14 x 1.25	FF1187-0803S	FF430	FF402-OA
m 10 x 1	FF1187-0804S	FF431	FF403-OA
1 1/4 - 18	FF1187-0805S	FF432	FF404-OA
1 - 18	FF1187-0806S	FF433	FF405-OA
7/8 - 18	FF1187-0807S	FF434	FF406-OA
5/8 - 18	FF1187-0808S	FF435	FF407-OA
3/4 - 16	FF1187-0809S	FF436	FF408-OA
7/8 - 14	FF1187-08010S	FF437	FF409-OA
9/16 - 18UNF - 2A	FF1187-08012S	FF11042	FF11041-OA
1 1/8 - 12UNF - 2A	FF1187-08014S	FF11301	FF10452-OA
1 1/8 - 12UNF - 2A	**FF1187-08015S	FF11303	FF11302-OA
m 20 x 1.5	FF1187-0816S	FF11499	FF11498-OA
m 25 x 1.5	FF1187-0817S	FF11826	FF11825-OA
3/8 - 18 NPT (Pipe)	2047-8-6S	FF439	FF411-OA
1/2 - 14 NPT (Pipe)	2047-8-8S	FF440	FF412-OA
3/4 - 14 NPT (Pipe)	2047-8-12S	FF441	FF413-OA

\* OA indicates overall length of hose assembly in inches. (Available to Aeroquip only.)

\*\* Long Drop Version for oil pans covered by sound attenuation shields.

## Large-capacity Vehicle Kit

All kits are designed to accommodate manual drain when necessary.

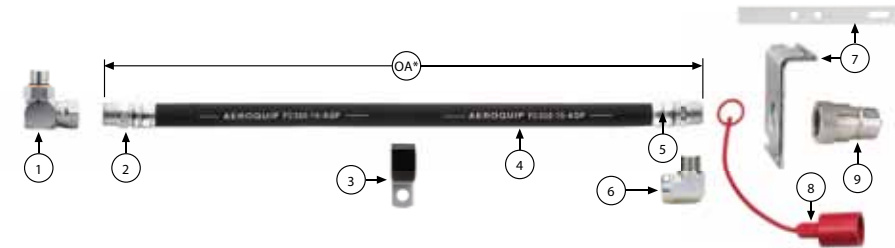

**These components are common to each kit regardless of the part number.**

Item #	Part #	Description
Item # 2	4412-8-12S	Hose Fitting (Reusable)
Item # 2	FJ3152-0812S	Hose Fitting (Crimp)
Item # 3	900729-8	Hose Clamp
Item # 4	FC350-12	Hose
Item # 5	4412-12-12S	Hose Fitting (Reusable)
Item # 5	FJ3152-1212S	Hose Fitting (Crimp)
Item # 7	FF9363-01S/ FF9270-01S	Bracket
Item # 8	5657-12	Dust Cap
Item # 9	5602-12-12S	Coupling Half

**Kit Part Numbers are selected by choosing the appropriate drain port thread size.**

Items Thread Size	#1 Oil Pan Adapter & Gasket	Hardware Kit (Includes Items 1, 3, 6, 7, 8, & 9)	Assembled Kit* (Includes Items 1 through 9)
3/4 - 14 NPT (Pipe)	2047-8-12S	FF943	FF293-OA
3/8 - 18 NPT (Pipe)	2047-8-6S	FF945	FF322-OA
7/8 - 18	FF1187-0807S	FF944	FF317-OA
7/8 - 14	FF1187-0810S	FF946	FF380-OA
1 - 18	FF1187-0806S	FF947	FF395-OA
1 - 11 1/2 NPT (Pipe)	2024-16-12S	FF948	FF833-OA
1/2 - 14 NPT (Pipe)	2024-8-12S	FF949	FF834-OA

\* OA indicates overall length of hose assembly in inches. (Available to Aeroquip only.)

# Remote Access (Weatherhead®) Conversion Kits

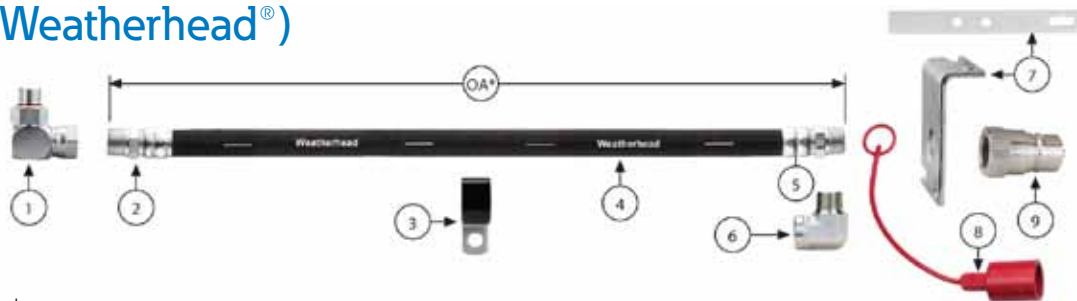

## Standard Vehicles

All kits are designed to accommodate manual drain when necessary.

**These components are common to each kit regardless of the part number.**

Item #	Part #	Description
Item # 2	06910E-108	Hose Fitting (Crimp)
Item # 3	900729-6	Hose Clamp
Item # 4	H56910	Hose
Item # 5	06910E-112	Hose Fitting (Crimp)
Item # 6	2089-12-12S	Connection At Mounting Flange
Item # 7	FF9363-01S	Bracket
Item # 8	5657-12	Dust Cap
Item # 9	5602-12-12S	Coupling Half

**Kit Numbers are selected by matching the drain port thread size with the oil pan adapter of the same thread.**

Thread Size	#1 Oil Pan Adapter & Gasket	Hardware Kit (Includes Items 1, 3, 6, 7, 8, & 9)
1/2 - 20	FF1187-0801S	FF428
m 18 x 1.5	FF1187-0802S	FF429
m 14 x 1.25	FF1187-0803S	FF430
m 10 x 1	FF1187-0804S	FF431
1 1/4 - 18	FF1187-0805S	FF432
1 - 18	FF1187-0806S	FF433
7/8 - 18	FF1187-0807S	FF434
5/8 - 18	FF1187-0808S	FF435
3/4 - 16	FF1187-0809S	FF436
7/8 - 14	FF1187-08010S	FF437
9/16 - 18UNF - 2A	FF1187-08012S	FF11042
1 1/8 - 12UNF - 2A	FF1187-08014S	FF11301
1 1/8 - 12UNF - 2A	**FF1187-08015S	FF11303
m 20 x 1.5	FF1187-0816S	FF11499
m 25 x 1.5	FF1187-0817S	FF11826
3/8 - 18 NPT (Pipe)	2047-8-6S	FF439
1/2 - 14 NPT (Pipe)	2047-8-8S	FF440
3/4 - 14 NPT (Pipe)	2047-8-12S	FF441

\* Hose fittings not included must be ordered separately #2, #4, #5. Hose length can be customized

\*\* Long Drop Version for oil pans covered by sound attenuation shields

## Large-capacity Vehicle Kit

All kits are designed to accommodate manual drain when necessary.

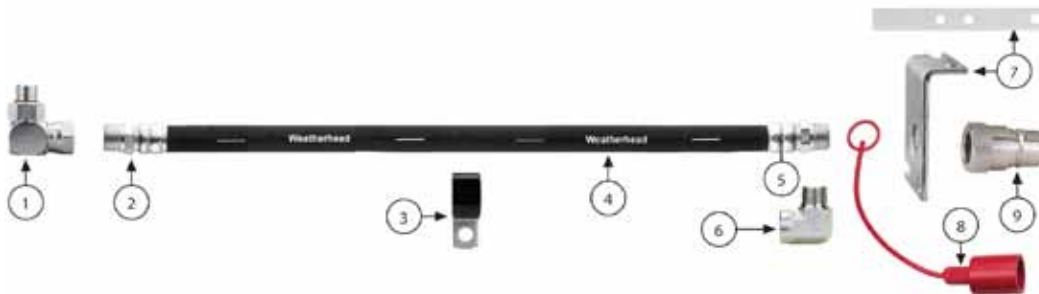

**These components are common to each kit regardless of the part number.**

Item #	Part #	Description
Item # 2	06912E-108	Hose Fitting
Item # 3	900729-8	Hose Clamp
Item # 4	H56912	Hose
Item # 5	06912E-112	Hose Fitting
Item # 6	2089-12-12S	Connection At Mounting Flange
Item # 7	FF9363-01S/ FF9270-01S	Bracket
Item # 8	5657-12	Dust Cap
Item # 9	5602-12-12S	Coupling Half

**Kit Part Numbers are selected by choosing the appropriate drain port thread size.**

Thread Size	#1 Oil Pan Adapter & Gasket	Hardware Kits (Includes Items 1, 3, 6, 7, 8, & 9)
3/4 - 14 NPT (Pipe)	2047-8-12S	FF943
3/8 - 18 NPT (Pipe)	2047-8-6S	FF945
7/8 - 18	FF1187-0807S	FF944
7/8 - 14	FF1187-0810S	FF946
1 - 18	FF1187-0806S	FF947
1 - 11 1/2 NPT (Pipe)	2047-8-16S	FF948
1/2 - 14 NPT (Pipe)	2047-8-8S	FF949

# Oil Thief System



## Providing easy access to oil samples for spectrographic analysis.

With the spectrographic analysis of engine oil being increasingly required, the problem of obtaining oil samples quickly, economically and efficiently has demanded more attention.

With the push of a button, an oil sample can be taken during the evacuation cycle of any FLOCS unit and collected in a standard sampling bottle for analysis. It takes less than 15 seconds to collect an oil sample with the Oil Thief.

Because oil-analysis facilities provide differing oil sample bottles, the FLOCS Oil Thief is available with a sample bottle port thread to match your needs. (Refer to the sample bottle thread sizes and corresponding Oil Thief part numbers listed in this chart.)

### Features:

- Push-button operation
- Light weight
- Repairable seals
- Accepts a wide variety of sample bottle threads

### Physical Characteristics:

Buna-N Seals for -40 to +225 Degrees Fahrenheit Service. Vacuum Capable to 28" Hg.

In a typical FLOCS system, a Male NPTF-to-Male NPTF adapter (2083-12-12s) is used on one end of the Oil Thief to connect to the female quick-disconnect coupling.

### Operating Instructions:

The Oil Thief is compatible with any FLOCS evacuation unit. Simply install an Oil Thief between the evacuation hose line and the coupling half; then attach a sample bottle. Wait a few seconds after starting the evacuation cycle (to flush away any oil from the last evacuation); then depress the sample collection button for approximately ten seconds. Release the button and remove the sample bottle. Clean the Oil Thief sample bottle port, attach another bottle and you are ready for the next sample.

### Note:

When not in use, the Oil Thief should have a spare sample bottle attached to maintain valve cleanliness.

### Benefits:

- No-mess oil sample
- Economical – one Oil Thief per maintenance bay evacuation pump
- Allows oil sampling while oil is still hot, without employee hazard

<b>Oil Thief Part Number</b>	<b>Sample Bottle Thread Size (In Inches)</b>
FF9300-75-0001	1.480-6 (or 38mm)
FF9300-75-0002	2.070-6
FF9300-75-0003*	1.580-6
FF9300-75-0004*	1.750-6 (or 45mm)

\*Available by special order.

# Remote Access Conversion Kit Installation

## 1. Selecting the Conversion Kit

Remove the oil pan drain plug and drain engine oil. Measure the thread on the pan plug with a thread gauge. The thread size will determine the specific conversion kit to be used. Kits are available in two styles: 1) assembly kits (contain mounting hardware and hose assembly), and 2) oil pan drain fitting and coupling with mounting bracket (installer must furnish hose assembly). Hose length in inches ("L") is added to the basic part number when ordering assembled kits.

## 2. Installation

Determine the length of hose required for your vehicle. If the hose length is not known, mount the quick disconnect coupling and bracket (see page 13) and route the hose from the coupling bracket to the oil pan drain. Refer to step 5 for proper routing, mark and cut the hose to length. Following step 3 install the hose fittings to complete the hose assembly. Install the oil pan drain fitting (per step 6) and the hose assembly.

Pan Plug Thread Size	Assembled Kit No.	Hardware Kit No.
1/2-20	F400-L	FF428
18 x 1.5 mm	FF401-L	FF429
14 x 1.25 mm	FF402-L	FF430
10 x 1mm	FF403-L	FF431
1 1/4-18	FF404-L	FF432
1-18	FF405-L	FF433
7/8 - 18	FF406-L	FF434
24 x 2mm	FF410-L	FF438
9/16 - 18	FF952-L	FF453
3/8 - 18 NPT (Pipe)	FF411-L	FF439
1/2 - 14 NPT (Pipe)	FF412-L	FF440
3/4 - 14 NPT (Pipe)	FF413-L	FF441

## 3. Assembling the Hose Line

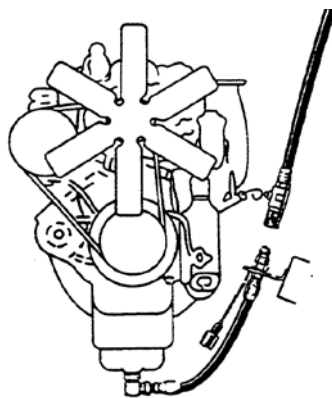

A. Put the socket in vise and screw hose into socket counterclockwise until it bottoms. Back off 1/4 turn.

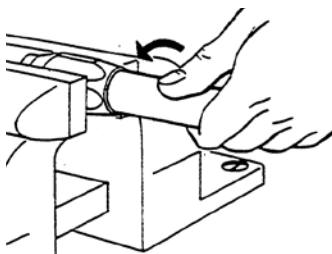

B. Oil nipple threads and inside of hose liberally. Use heavy lube oil.

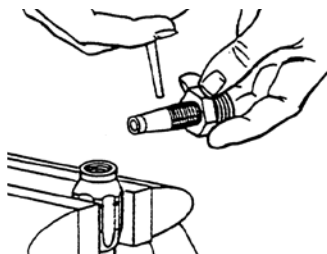

C. Screw nipple clockwise into socket and hose. Keep hose from turning while assembling nipple. Leave 1/32" to 1/16" clearance between nipple hex and socket.

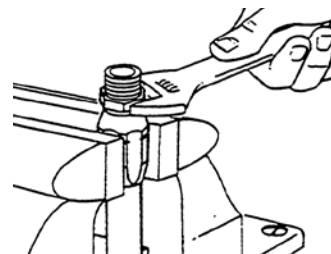

## 4. Mounting the Coupling

**Note:** The coupling bracket should be mounted so that the coupling valve is located above the oil level in the crank case. Make sure that the coupling is mounted firmly and located so that it will not be damaged during normal operation of the vehicle.

A. Attach mounting bracket to desired location on vehicle, preferably near the dipstick. Screw assembled fitting into bracket until enough thread is exposed on opposite side to assemble and tighten the quick disconnect coupling.

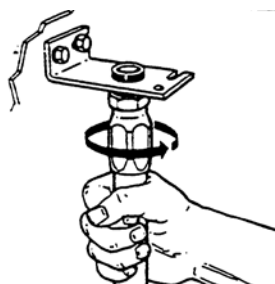

B. Assemble dust cap and coupling to mounted hose fitting. Use pipe thread sealant. Check for any leakage after kit is installed.

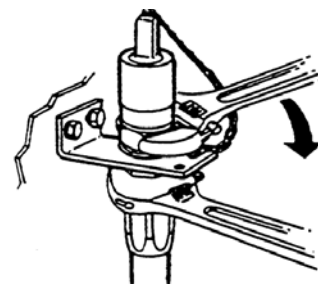

# Remote Access Conversion Kit Installation Continued

## 5. Routing the Hose

A. Avoid heat. If the hose must be routed past the manifold or exhaust pipe, use Firesleeve for heat protection.

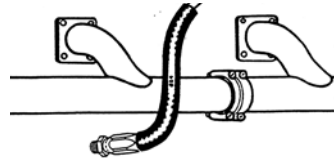

B. Avoid sharp or abrasive edges. Use Eaton protective coil/sleeve if hose might be cut or chafed or use support clamp provided to avoid abrasion.

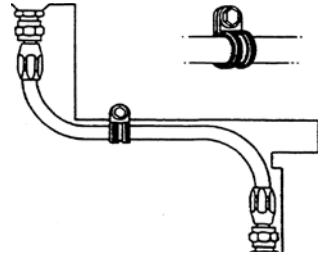

C. Avoid kinking. Tight bends may kink hose. Observe bend radius limitations.

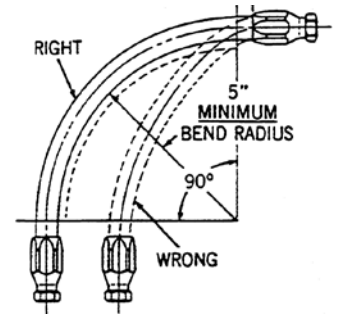

## 6. Installing the Oil Pan Drain Fitting

A. Lubricate the O-ring seal on the Oil Pan Drain Fitting. Screw the fitting into the oil pan until the last thread on the upper set of threads is engaged.

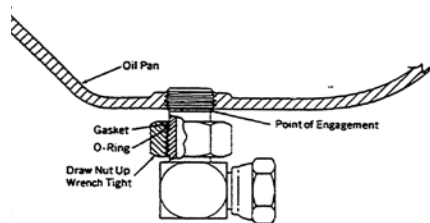

B. Position the elbow and tighten the jam nut (two wrenches needed). Screw the hose fitting into the elbow and tighten all connections.

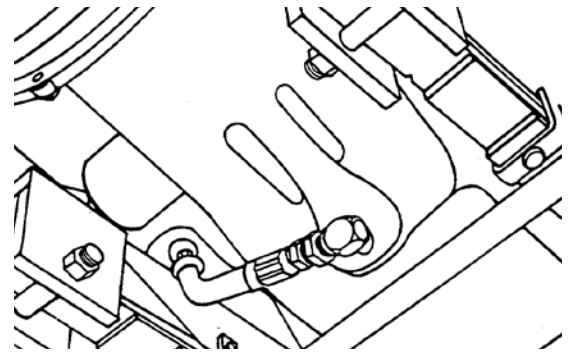

C. Oil may be manually drained by disconnecting the hose fitting from the oil pan adapter.

# Air Units

## FLOCS 30A Air-powered Unit

### Operation and Service Info

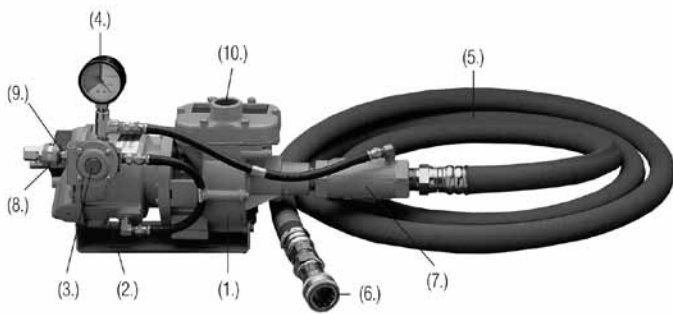

- |  |                             |
|--|-----------------------------|
| 1. Piston pump                           | 6. Coupling half**          |
| 2. 5 cfm air-operated motor (80-150 psi) | 7. Suction strainer         |
| 3. Override button                       | 8. 1/4" air-supply coupling |
| 4. Cycle gauge                           | 9. 1/4" air-supply nipple   |
| 5. 15' of 1" I.D. suction hose*          | 10. 1" NPT discharge port   |

### Specifications

- Maximum discharge pressure: 1/5 of the input air pressure (power source).
- Recommended operating temperature of fluid: +60° to 180°.
- Strainer screen size: size 35 mesh.
- Flow rate: see flow chart on page 16.
- Pump power source: 80 to 150 psi air at 5 CFM minimum.
- Fluid handling compatibility: all petroleum base fluids below 6000 SSU
- Minimum discharge line: size 1" I.D. (-16).
- Mounting requirements: see Fig. 3, page 14.
- 15' of 1" I.D. suction line standard.
- 5601-12-12 female coupling.

### Installation Instructions

Mount the unit for easy accessibility to the vehicles to be serviced. It may be mounted in either a horizontal or vertical position. A mounting bracket is provided for rigid mounting of the pump (reference Figure 3 for detail dimensions). The pump motor operates on 80-150 psi air at 5 CFM minimum. The unit is to be mounted so that the cycle gauge is in full view of the operator and the override button and strainer cleanout are readily accessible.

1. Connect the used oil discharge line to the 1" pipe port at the top of the unit. The discharge line must be no higher than 10 feet above FLOCS unit. It is important to keep the discharge line large to maintain maximum efficiency. Use a 1" I.D. pipe for lines 15' to 30' long and a 1 1/4" I.D. pipe for lines 30' to 100' long. Make sure the discharge line does not develop more head pressure than 1/5 of the air pressure

### Operation

The FLOCS 30A unit is a simple self-controlled automatic oil evacuator. Once it has been started it will operate until all the oil has been evacuated from the oil pan. The unit will stop automatically when air enters the suction hose.

This unit is controlled by a normally closed, air supply shut-off valve, which requires the pump vacuum to hold it open. At the end of the evacuation cycle air in the suction line destroys the vacuum causing the control valve to shut off the air pressure supply and stop the pump. The unit also incorporates a strainer to prevent

large particles from damaging the pump.

### To operate:

1. Attach the FLOCS 30A unit quick disconnect coupling to the mating conversion kit coupling half on the equipment.
2. Press the red override button to start the unit; hold for approximately 5 seconds. Cycle gauge will indicate run condition.
3. The unit will shut off automatically when all oil is evacuated. The cycle gauge will indicate when the unit is off. Disconnect the evacuation line.

source. (Example: air power source of 150 psi, discharge head pressure of 30 psi maximum.)

2. Connect the air supply line into the 1/4" NPTF port of the quick disconnect coupling supplied with the unit. The air supply line should be equipped with an air line water filter to prevent water from contaminating the pump control and/or causing freezing-up. A lubricator is also recom-

mended for the air supply line (use non-detergent oil in the lubricator).

3. Install the 15' evacuation line by screwing the swivel hose fitting into the female thread on the strainer. Use pipe dope to insure a proper seal. Do not over tighten.

### Note:

The unit should not be mounted in a position requiring more than 10 feet of evacuation lift.

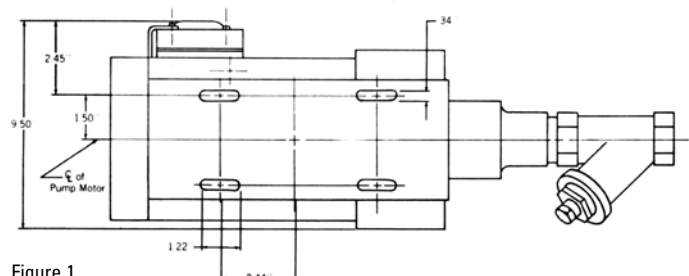
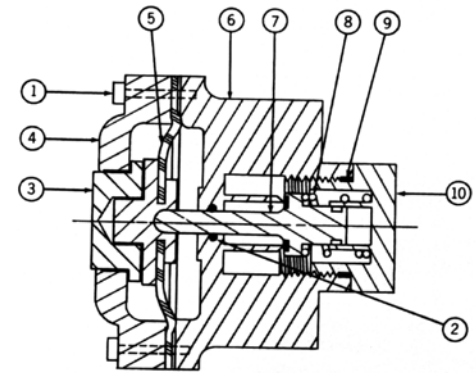
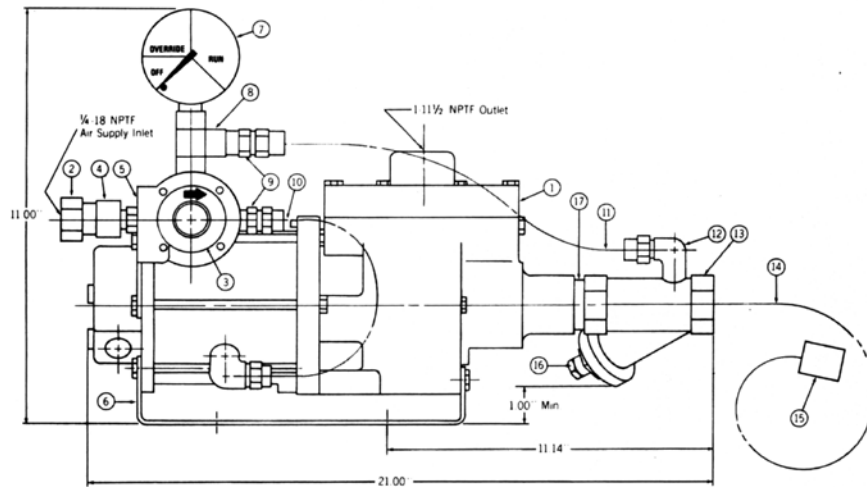

Figure 1

# Air Units

## FLOCS 30A Parts List and Assembly Drawing

Operation and Service Info



Item No.	Quantity Required	Description	Part No.	Basic Material
1	1	Pump	FF9330A-02	Cast Aluminum
2	1	Coupling Half	FD40-1000-04-04	Steel
3	1	Shut-off Valve	FF9330A-03	Aluminum
4	1	Coupling Body	FD40-1014-04-04	Steel
5	1	Bracket	FF9330A-14	Steel
6	1	Bracket	FF9330A-13	Steel
7	1	Cycle Gauge	FF9330A-11	Steel
8	1	Service Tee	2092-4-4S	Steel
9	1	Adapter	2021-4-4B	Brass
10	2	Hose Assembly	255603-4B-8	Brass Fittings
11	1	Hose Assembly	255603-4B-13	Brass Fittings
12	2	Adapter	2024-4-4B	Brass
13	1	Strainer	FF9330A-12	Steel
14	1	Hose Assembly	FA1552KMM1800	Steel Fittings
15	1	Coupling Half	5501-12-12S	Steel
16	1	Pipe Plug	2082-12S	Steel
17	1	Adapter	2084-16S-11/2	Steel

### Shut-Off Valve Parts List

Item No.	Quantity Required	Description	Part No.	Basic Material
1	4	Screw	FF9144-0110-12	Steel
2	1	O-ring	22550-008	Buna-N
3	1	Button	FF9330A-09	Aluminum
4	1	Cover	FF9330A-10	Aluminum
5	1	Diaphragm	FF9330A-08	Steel and Rubber
6	1	Valve Body	FF9330A-04	Cast Aluminum
7	1	Valve	FF9330A-05	Brass & Rubber
8	1	Spring	FF9330A-06	Spring Steel
9	1	O-ring	22550-018	Buna-N
10	1	Cap	FF9330A-07	Plastic

# Air Units

## FLOCS 30A Parts List and Assembly Drawing

### Operation and Service Info

#### Servicing Components

Instructions for Rebuilding Shut-Off valve (P/N FF9330A-03)

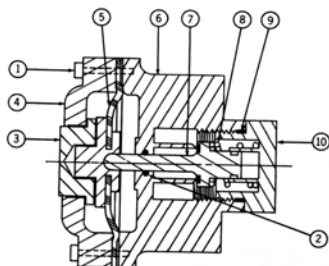

Figure 2

1. Remove the four cover screws, #1; remove button, #3; remove and replace diaphragm if necessary, #5. For assembling, torque cover screws 25-30 in.-lbs.
2. Remove plastic cap, #10; spring, #8, and valve, #7. Replace the O-ring seal, #9, on the cap. Check the bonded seal on the valve, #7; inspect for foreign particles or burrs and replace if necessary.
3. Replace O-ring seal, #2, with a 22559-00B O-ring. Care must be taken not to scar the seal area upon removal of the O-ring.
4. Lubricate all seals with petroleum jelly prior to installation. Make sure all metal parts are clean and not damaged.

5. Assemble in reverse order.

#### Note:

A complete shut-off valve is available as an assembly for replacement.

Order by Part Number **FF9330A-03**.

#### Servicing the Strainer

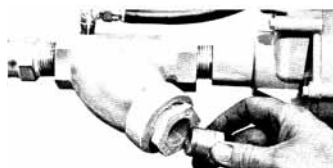

The strainer should be serviced daily under normal fleet operation conditions. If the strainer becomes clogged or partially blocked with residue, the evacuation operation will slow down due to lack of oil flow to the pump.

1. Remove the strainer clean-out plug and screen.
2. Wash the plug and screen with clean fuel oil.
3. Replace the plug and screen. Tighten wrench-tight.
4. Be careful not to crack the castings or pipe bushings when reassembling the plug. Cracked and/or leaking castings will result in insufficient pumping.

#### Troubleshooting the FLOCS 30A

**Problem:** Unit will not run when override button is pushed.

#### Correction

- A. Check the air supply line to see if it is connected and the air is turned on.

**Problem:** Unit will not continue running after the button is released.

#### Correction

- A. Button was not in override long enough; hold override button until cycle gauge indicates run.

- B. Check for vacuum leakage at strainer suction line, vehicle kit and/or hose fittings on control regulator.
- C. Check air pressure and CFM to make sure that the minimum 80 psi and 5 CFM are available to pump.
- D. Check the strainer for contamination.
- E. Check regulator for damaged seals or diaphragm. Reference Figure 2, page 16 for servicing.
- F. Check oil dipstick; oil pan may be empty.

connections.

**Problem:** Unit shuts off before all oil is evacuated.

#### Correction

- A. Check all threaded connections in suction line for vacuum leakage. Mount vacuum gauge in mating coupling half. Plug into end of suction line. Run pump to get a vacuum. Watch gauge. A sudden loss of vacuum indicates a suction leak.

**Problem:** Unit will not shut off after all the oil has been evacuated.

#### Correction

- A. Check for plugged coupling at vehicle kit.
- B. Check regulator for damaged seals or diaphragm. Reference Figure 2, page 16 for servicing.

**Problem:** Cycle gauge will not indicate the mode the pump is in.

#### Correction

- A. Check gauge to see if indicator hand is loose.
- B. Check for any leaks in thread and hose fitting

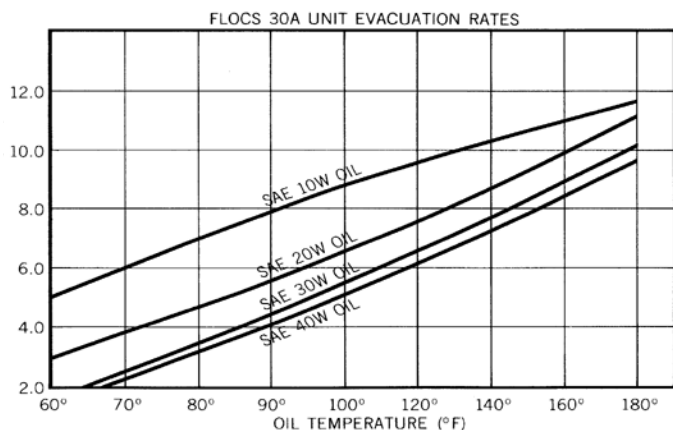

# Electric Units

## FLOCS 15 Electric-powered Unit

### Operation and Service Info

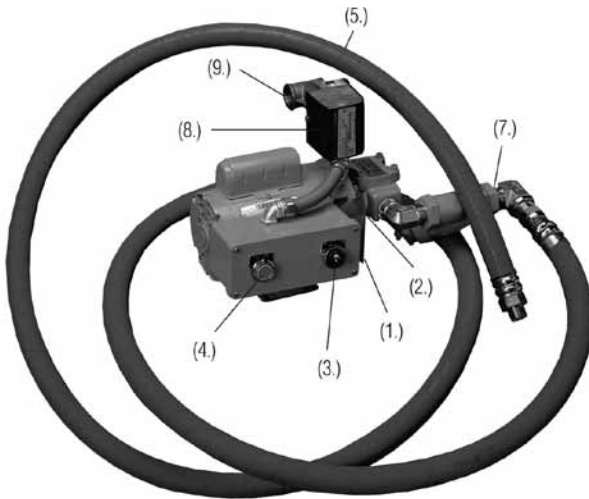

#### Specifications

- Maximum discharge pressure-50 psi
- Maximum fluid lift-10ft
- Operating temperature (of fluid) +20° to +180°
- Strainer screen size-35 mesh
- Flow rate-see flow chart page 24
- Motor electrical rating-

#### Installation Instructions

Mount the unit for easy accessibility to vehicles to be serviced. The pump motor operates on 115V AC 20 AMP. To install unit:

1. Remove cover plate from the control panel.
2. Drill an access hole on the side or the bottom of the control box (3/4" hole recommended for conduit). Run service wiring through access hole.

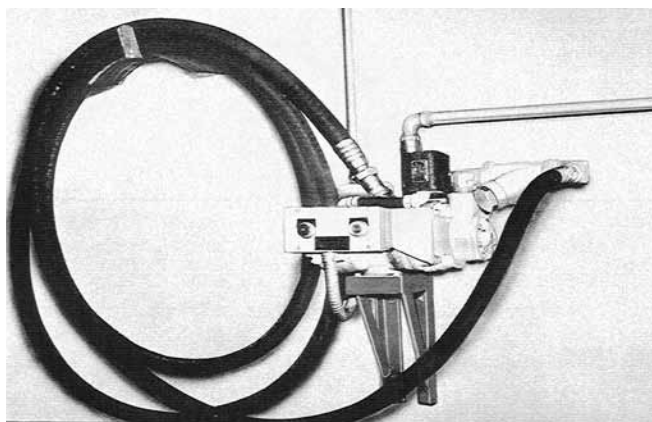

1. 3/4 hp electric motor 115V AC, 20 amp
2. Gear pump
3. Cycle-run starter button
4. Cycle-run signal light
5. 15' of 1" I.D. suction hose\*
6. Coupling half\*\*
7. Suction strainer
8. 115V AC flow-control switch
9. Backflow check valve with a 3/4" NPT discharge port

The FLOCS 15 is a simple, almost totally automatic machine.

#### To operate:

1. Attach the suction line coupling half to the FLOCS coupling half on the vehicle. To connect the coupling, retract the knurled sleeve, push the coupling halves together and release the sleeve.
2. Press the cycle start button to start the unit. The cycle run light will come on.
3. The unit will shut off automatically when all oil is evacuated. The signal light will shut off. Disconnect the evacuation line.

- 115V., 60CY., 20 APM AC
- Fluid handling compatibility-all petroleum base fluids below 6000 SSU

- Minimum discharge line 3/4" I.D.
- Mounting requirements-per NEMA 56 C Frame

3. Connect a service grounding wire to one of the two bracket bolts on the side of the control box.
4. Connect the live wire to the 6" black lead.
5. Connect the neutral wire to the 6" white lead.
6. Tighten conduit or cord connector in 3/4" access hole.
7. Replace control panel and tighten in place.
8. Connect the old oil discharge line to the 3/4" NPT port on the check valve.
9. Install the 15' evacuation line by screwing the swivel hose fitting into the female NPT thread on the strainer adapter (a 90° adapter is available to suit installation). Caution: Do not over tighten pipe

threads into strainer. The use of pipe sealant is recommended.

10. The timing relay (in the control box) is factory set for 25 seconds. The purpose of the timing relay is to keep the pump engaged until the initial flow of oil reaches the pump from the vehicle. For instructions on adjustment of the timing relay, see page 20.

#### Note:

The unit should not be mounted more the 10 ft. above floor level to allow no more than 10 ft. of evacuation height. The discharge line should be plumbed so as not to cause more than 50 psi head pressure.

# Electric Units

## FLOCS 15 Assembly Drawing

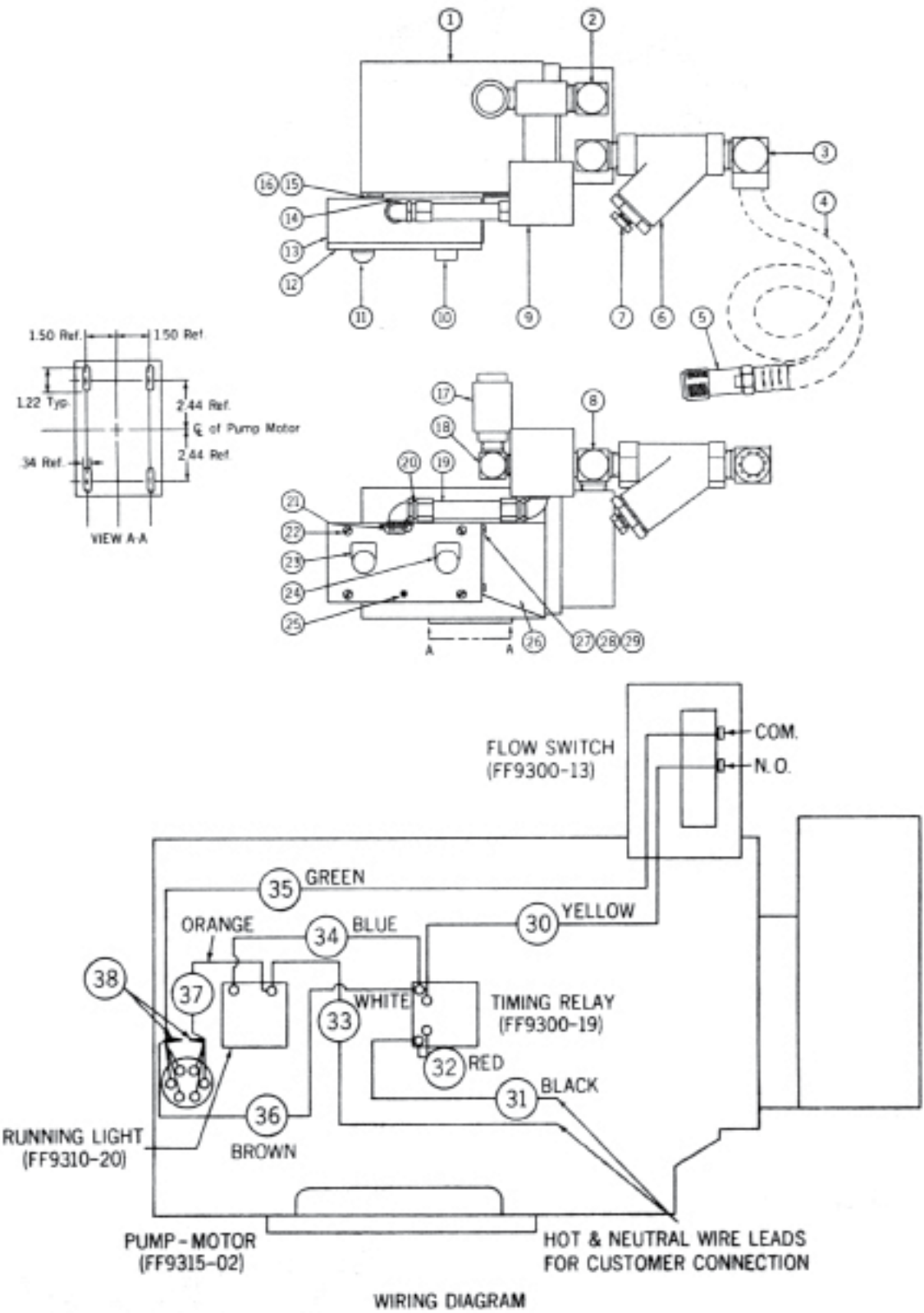

# Electric Units

## FLOCS 15 Part List

Item Number	Quantity Required	Description	Part Number	Basic Material
1	1	Pump Motor	FF9315-02	Steel
2	1	Adapter	2085-16-12S	Steel
3	1	Adapter	2089-16-16S	Steel
4	1	Hose Assembly	FA1552KMM1800	Steel
5	1	Coupling Half	5601-12-12S	Steel
6	1	Strainer	FF9315-03	Steel
7	1	Pipe Plug	2082-12S	Steel
8	1	Adapter	2085-16-16S	Steel
9	1	Flow Switch	FF9300-13	Steel
10	1	Timing Relay	FF9300-19	Steel
11	1	Running Light	FF9310-20	Steel
12	1	Cover	FF9315-20	Steel
13	1	Control Box	FF9315-05	Steel
14	1	Decal	FF9315-10	-
15	1	Conduit Nipple	FF9315-18	Steel
16	2	Lock Nut	FF9315-19	Steel
17	1	Check Valve	FF9315-24	Brass
18	1	Adapter	2085-12-12S	Steel
19	1	Conduit	FF9315-23	Steel & PVC
20	2	90° Angle Connector	FF9315-22	Steel
21	3	Reducing Washer	FF9315-21	Steel
22	4	Screw	210002-1-8-7S	Steel
23	1	Legend Plate	FF9315-07	Steel
24	1	Legend Plate	FF9315-06	Steel
25	1	Decal	FF9315-09	-
26	1	Bracket	FF9315-08	Steel
27	2	Bolt	FF9309-0110-04S	Steel
28	2	Lock Washer	210104-1-10S	Steel
29	2	Nut	FF9236-0110S	Steel
30	1	Wire Assembly	FF9315-11	Copper & Vinyl
31	1	Wire Assembly	FF9315-17	Copper & Vinyl
32	1	Wire Assembly	FF9300-30	Copper & Vinyl
33	1	Wire Assembly	FF9315-16	Copper & Vinyl
34	1	Wire Assembly	FF9315-13	Copper & Vinyl
35	1	Wire Assembly	FF9315-12	Copper & Vinyl
36	1	Wire Assembly	FF9315-25	Copper & Vinyl
37	1	Wire Assembly	FF9315-15	Copper & Vinyl
38	2	Wire Connector	FF9310-38	Steel & Plastic

# Servicing Components

## Instructions on adjustments of the flow switch:

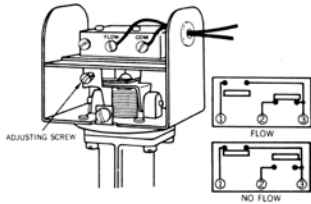

Figure 3

1. Remove the black switch cover by loosening the two screws on the side and pull off the cover.
2. If a small amount of oil remains in the crankcase after the pump shuts off, the adjusting screw should be turned counterclockwise to decrease the sensitivity of the switch. DO NOT remove the screw completely or back it out so far as to cause interference with the replacement of the cover.
3. If the pump stays on when no oil is flowing, the adjusting screw should be turned clockwise until the pump shuts off.

## Instructions on adjustment of the time delay-relay switch:

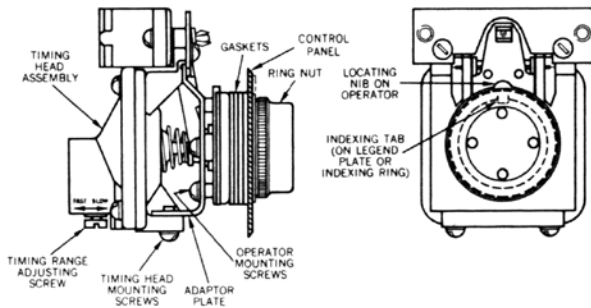

Figure 4

1. The timing relay is factory pre-set for a normal time delay on most applications (approximately 25 seconds).
2. To increase the time setting, turn the adjusting screw clockwise.
3. To decrease the time setting, turn the adjusting screw counterclockwise. A fraction of a turn will add or subtract 10-15 seconds of time.

## Servicing the Strainer:

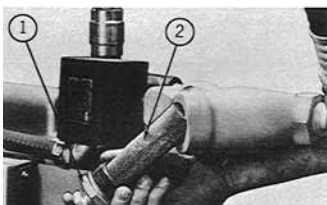

Figure 5

The strainer should be serviced daily under normal operating conditions. If the strainer becomes clogged or partially blocked with engine residue, the evacuation operation will slow down due to lack of oil flow to the pump.

1. Remove the strainer clean out plug (Figure 5-1), and pull the screen (Figure 5-2) out.
2. Wash the plug and screen in clean fuel oil.
3. Place screen in plug counter bore and replace assembly in strainer housing. Tightening plug wrench tight. Use of pipe thread sealant is recommended.

# Troubleshooting

**Problem:** Unit operates approximately 25 seconds, then shuts off before all of the oil is out of the vehicle engine.

**Correction:**

- A. Oil may have too heavy viscosity due to a heavy weight oil or cold oil. The engine of the vehicle should be started and run to heat the oil to above 70° or set the time delay switch to hold the pump engaged longer than the standard 25 seconds factory setting. See time delay switch adjustment (Figure 4), page 20.
- B. Strainer screen may be plugged with foreign material. Clean strainer screen in diesel fuel (Figure 5), page 20.
- C. The FLOCS unit may be trying to lift oil from too low a level. 10 feet lift is maximum. Move the FLOCS unit closer to the vehicle oil pan level.
- D. Hose connections may not be right at the vehicle pan plug. Check and tighten hose to plug union connection.

**Problem:** Unit doesn't go into the evacuation cycle when "cycle run" button is pushed.

**Correction:**

- A. Check wiring to be sure there are no broken or disconnected wires.
- B. Check fuse on the power line to be sure power is being supplied to the unit.

**Problem:** Evacuation is not fully completed when unit shuts off.

**Correction:**

- A. Flow switch may be set too high and be too sensitive to the lower stream of oil near the completion of evacuation. Adjust flow switch (Figure 3), page 20.
- B. Broad flat oil pans with drain connection coming out the side instead of the bottom can cause air to enter into the drain line causing premature shut off. Run a second cycle by resetting the cycle start button.
- C. Cold oil in the oil pan can cause slow drain down of the oil pan and allow the FLOCS unit to shut off prematurely. Start vehicle engine and warm oil above 70° before evacuating.

**Flow Rate Chart**

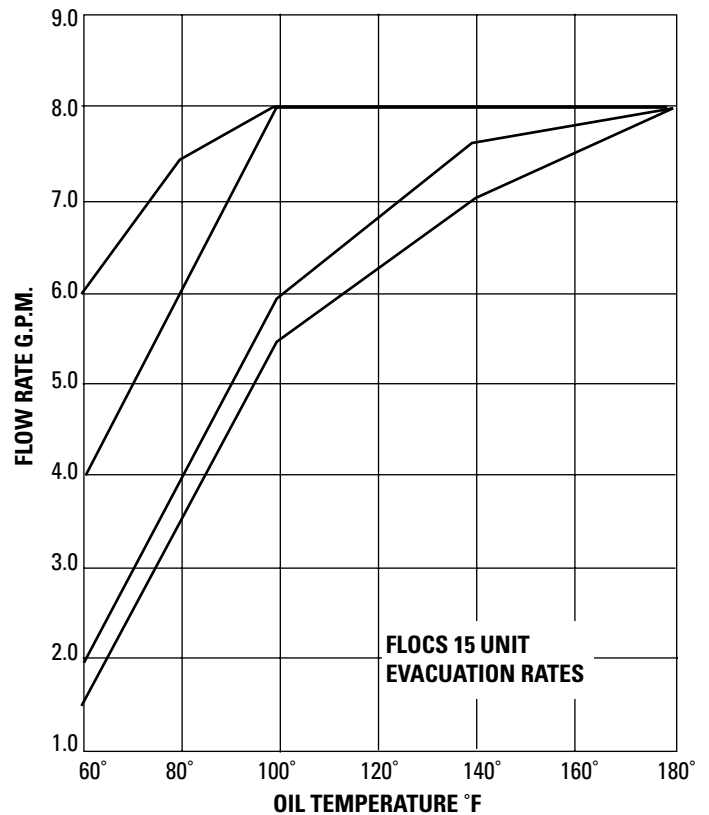

Eaton  
Hydraulics Group USA  
14615 Lone Oak Road  
Eden Prairie, MN 55344  
USA  
Tel: 952-937-9800  
Fax: 952-294-7722  
[www.eaton.com/hydraulics](http://www.eaton.com/hydraulics)

Eaton  
Hydraulics Group Europe  
Route de la Longeraie 7  
1110 Morges  
Switzerland  
Tel: +41 (0) 21 811 4600  
Fax: +41 (0) 21 811 4601

Eaton  
Hydraulics Group Asia Pacific  
Eaton Building  
4th Floor, No. 3 Lane 280 Linhong Rd.  
Changning District  
Shanghai 200335  
China  
Tel: (+86 21) 5200 0099  
Fax: (+86 21) 5200 0400