



*Powering Business Worldwide*

## Motion Control Valves

Motion control functions for applications  
up to 350 bar (5000 psi) and 550 L/min (143 USgpm)



F

*Where measurements are critical request certified drawings. We reserve the right to change specifications without notice.*

# Motion Controls

## Valve locator

### Functional Symbol

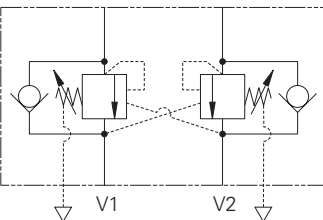
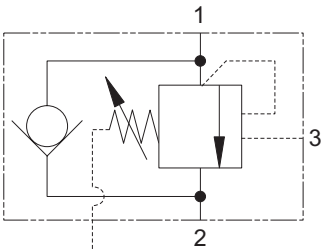
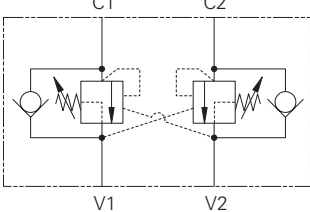
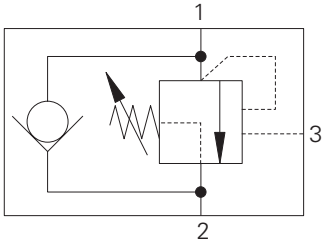
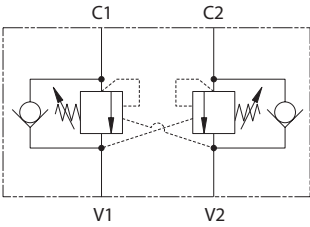
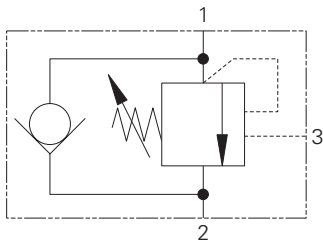

Model	Cavity	Flow Rating	Typical Pressure	Page
		<b>L/min (USgpm)</b>	<b>bar (psi)</b>	
<i>OCV standard</i>				
1CE20	A22903	20 (5)	270 (4000)	F-100
1CE30	A6610	30 (8)	270 (4000)	F-110
1CEH30	A6610	30 (8)	350 (5000)	F-112
1CE90	A12336	90 (23)	270 (4000)	F-170
1CEH90	A12336	90 (23)	350 (5000)	F-172
1CE120	A877	120 (32)	270 (4000)	F-230
1CE140	A20081	140 (37)	340 (4390)	F-280
1CE300	A6935	300 (80)	270 (4000)	F-310
1SE30	A20090-T11A	30 (8)	270 (4000)	F-360
1SE90	A20092-T2A	90 (23)	270 (4000)	F-400
1SE140	A20094-T17A	140 (37)	340 (4390)	F-440

Model	Cavity	Flow Rating	Typical Pressure	Page
		<b>L/min (USgpm)</b>	<b>bar (psi)</b>	
<i>OCV part balanced</i>				
1CER30	A6610	30 (8)	270 (4000)	F-120
1CERH30	A6610	30 (8)	350 (5000)	F-122
1CER90	A12336	90 (23)	270 (4000)	F-180
1CERH90	A12336	90 (23)	350 (5000)	F-182
1CER140	A20081	140 (37)	340 (4390)	F-290
1SER30	A20090-T11A	30 (8)	270 (4000)	F-370
1SER90	A20092-T2A	90 (23)	270 (4000)	F-410
1SER140	A20094-T17A	140 (37)	340 (4390)	F-450

Model	Cavity	Flow Rating	Typical Pressure	Page
		<b>L/min (USgpm)</b>	<b>bar (psi)</b>	
<i>OCV fully balanced</i>				
1CEB30	A6610	30 (8)	270 (4000)	F-130
1CEB90	A12336	90 (23)	270 (4000)	F-190
1CEB120	A877	120 (32)	270 (4000)	F-240
1CEB300	A6935	300 (80)	270 (4000)	F-320
1SEB30	A20090-T11A	30 (8)	270 (4000)	F-380
1SEB90	A20092-T2A	90 (23)	270 (4000)	F-420

Where measurements are critical request certified drawings. We reserve the right to change specifications without notice.

# Motion Controls

## Valve locator

### Functional Symbol

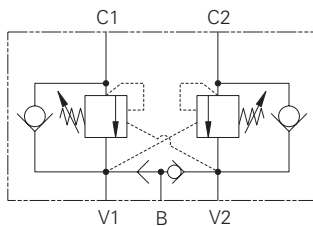
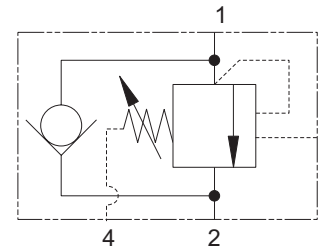
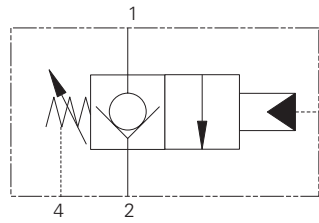
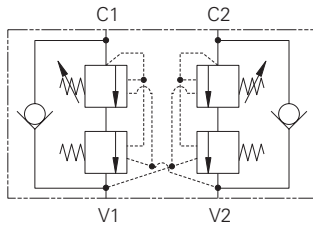
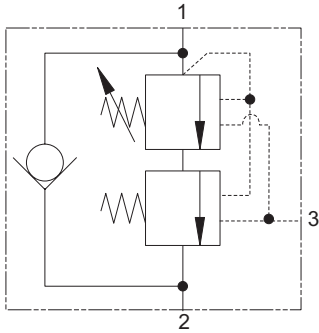

Model	Cavity	Flow Rating	Typical Pressure	Page
		<b>L/min (USgpm)</b>	<b>bar (psi)</b>	
<i>OCV counterbalanced</i>				
1CEL30	A6610	30 (8)	380 (5510)	F-140
1CEL90	A12336	90 (23)	380 (5510)	F-210
1CEL140	A20081	140 (37)	380 (5510)	F-300
1SEL30	A20090-T11A	30 (8)	380 (5510)	F-390
1SEL90	A20092-T2A	90 (23)	380 (5510)	F-430
1SEL140	A20094-T17A	140 (37)	380 (5310)	F-460

Model	Cavity	Flow Rating	Typical Pressure	Page
		<b>L/min (USgpm)</b>	<b>bar (psi)</b>	
<i>OCV zero differential</i>				
1CPBD30	AXP 20530	30 (8)	350 (5000)	F-150
1CPBD90	A12196	90 (23)	350 (5000)	F-220
1CPBD120	A6726	180 (47)	400 (5800)	F-260
1CPBD300	A13098	300 (80)	400 (5800)	F-340

Model	Cavity	Flow Rating	Typical Pressure	Page
		<b>L/min (USgpm)</b>	<b>bar (psi)</b>	
<i>OCV fully balanced</i>				
1CEBD30	A20530	30 (8)	350 (5000)	F-132
1CEBD90	A12196	90 (23)	270 (4000)	F-200
1CEBD120	A6726	180 (47)	270 (4000)	F-250
1CEBD300	A13098	300 (80)	270 (4000)	F-330

Model	Cavity	Flow Rating	Typical Pressure	Page
		<b>L/min (USgpm)</b>	<b>bar (psi)</b>	
<i>Motion control valve, with brake shuttle</i>				
1CEESH35		30 (8)	270 (4000)	F-470
1CEESH95		90 (23)	270 (4000)	F-480
1CEESH150		150 (40)	270 (4000)	F-490
1CEESH350		300 (80)	270 (4000)	F-500

Where measurements are critical request certified drawings. We reserve the right to change specifications without notice.

# Motion Controls

## Valve locator

### Functional Symbol

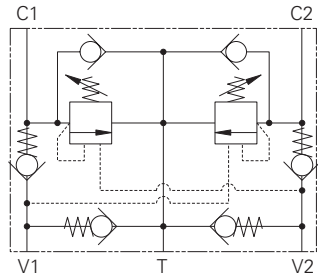

Model	Cavity	Flow Rating	Typical Pressure	Page
		<b>L/min (USgpm)</b>	<b>bar (psi)</b>	
<i>Motion control valve &amp; lock</i>				
1CEEC35		30 (8)	270 (4000)	F-510
1CEEC95		95 (25)	270 (4000)	F-520
1CEEC150		150 (40)	270 (4000)	F-530
1CEEC350		300 (80)	270 (4000)	F-540

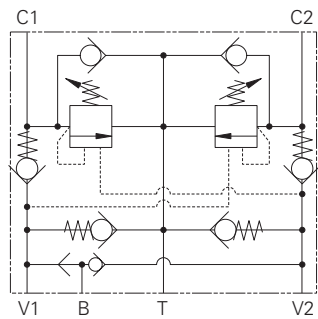

Model	Cavity	Flow Rating	Typical Pressure	Page
		<b>L/min (USgpm)</b>	<b>bar (psi)</b>	
<i>Motion control valve &amp; lock with brake shuttle</i>				
1CEEC3H35		30 (8)	270 (4000)	F-550
1CEEC3H95		95 (25)	270 (4000)	F-560
1CEEC3H150		150 (40)	270 (4000)	F-570
1CEEC3H350		350 (80)	270 (4000)	F-580

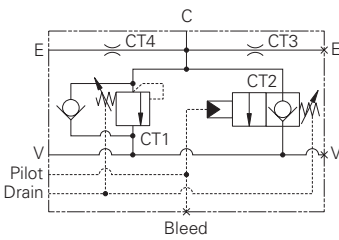

Model	Cavity	Flow Rating	Typical Pressure	Page
		<b>L/min (USgpm)</b>	<b>bar (psi)</b>	
<i>BoomLoc</i>				
1CEBL256		250 (66)	350 (5000)	F-600
1CEBL356		350 (92)	350 (5000)	F-610

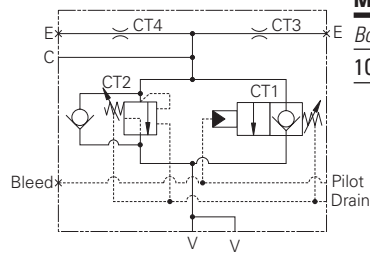

Model	Cavity	Flow Rating	Typical Pressure	Page
		<b>L/min (USgpm)</b>	<b>bar (psi)</b>	
<i>BoomLoc</i>				
1CEBL556		550 (145)	400 (5800)	F-620

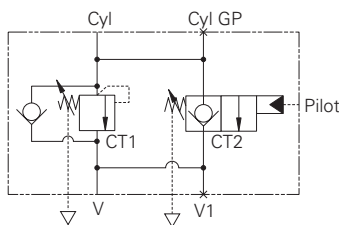

Model	Cavity	Flow Rating	Typical Pressure	Page
		<b>L/min (USgpm)</b>	<b>bar (psi)</b>	
<i>BoomLoc</i>				
1CEBL31F3W35P		30 (8)	350 (5000)	F-630

Where measurements are critical request certified drawings. We reserve the right to change specifications without notice.

# Motion Controls

## Valve locator

### Functional Symbol

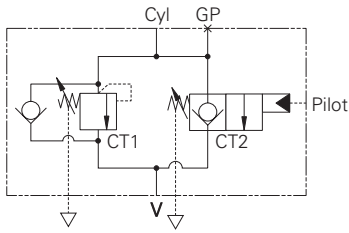

Model	Cavity	Flow Rating	Typical Pressure	Page
<i>BoomLoc</i>		L/min (USgpm)	bar (psi)	
1CEBL31F1/2635P		30 (8)	350 (5000)	F-640

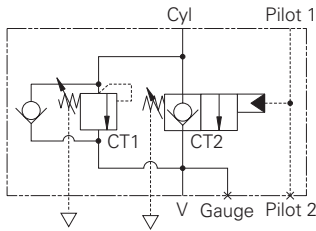

Model	Cavity	Flow Rating	Typical Pressure	Page
<i>BoomLoc</i>		L/min (USgpm)	bar (psi)	
1CEBL31F4W35P		30 (8)	350 (5000)	F-650

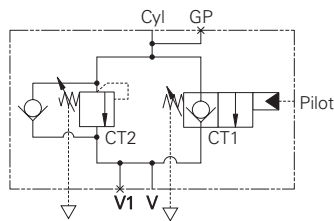

Model	Cavity	Flow Rating	Typical Pressure	Page
<i>BoomLoc</i>		L/min (USgpm)	bar (psi)	
1CEBL91F4W35P		90 (24)	350 (5000)	F-660

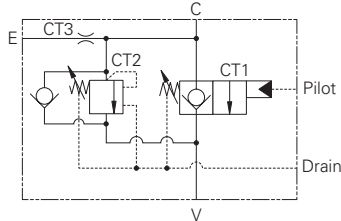

Model	Cavity	Flow Rating	Typical Pressure	Page
<i>BoomLoc</i>		L/min (USgpm)	bar (psi)	
1CEBL151F4W35P		150 (40)	350 (5000)	F-670

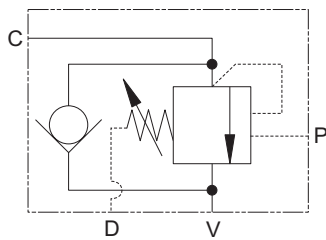

Model	Cavity	Flow Rating	Typical Pressure	Page
<i>BoomLoc</i>		L/min (USgpm)	bar (psi)	
1CEBL153F4W35P		150 (40)	350 (5000)	F-680

**F**

# Motion Control Valves

## Section Contents

This section contains a most extensive range of overcenter and motion control cartridges, including normal, part vented and fully vented versions. Suitable for load holding, load safety and to prevent load runaway, giving low pressure drops, various pilot ratios and excellent stability to all types of moving loads.

### Adjustments

The adjustment range and Max setting figures shown throughout this catalogue give the design range for each valve, higher or lower values may be attainable but should not be used without first contacting our Engineering department. Setting must ALWAYS be carried out using an appropriate gauge and it must NOT be assumed that screwing an adjuster to its maximum or minimum position will yield the maximum or minimum stated design setting for that valve.

F

#### **1CE/1CEE**

Overcenter cartridge pilot assisted relief with check

To control moving loads and prevent load runaway, giving load holding and hose failure safety

#### **1CER**

Overcenter cartridge as 1CE series with relief balanced

As 1CE series but with relief balanced against back pressure allowing the valve to be used with closed center DCV with service line reliefs

#### **1CEB/1CEBD**

Overcenter cartridge as 1CE series with relief and pilot balanced

As 1CE series but balanced on relief and pilot areas. For use on proportional systems or applications with widely varying back pressures

#### **1CEL**

Overcenter cartridge with constant counterbalance pressure

This valve is used in systems where the machine framework introduces instability, such as telescopic handlers, cranes and concrete pumps

#### **1CPB/1CPBD**

Pilot controlled cartridges without relief function, unaffected by back pressure

For use on boom lock applications giving load-holding and hose failure safety. With or without internal relief

#### **1CEEC**

Line mounted overcenter with make up checks. Piece parts in body style

Motion control valves with make up checks and cross line relief function for use on transmission systems or single rod cylinders when dual relief is required

#### **1CEESH/1CEESH**

As ICEEC series with brake shuttle. Piece parts in body style

As ICEEC series but with added brake shuttle for removal of spring applied park brakes

#### **1CEBL**

In-line or cylinder mounted BoomLoc valves incorporating 1CPB(D) cartridge and additional relief cartridge element

These overcenter valves are suitable for use on the boom and dipper cylinders of an excavator to help the manufacturer or user comply with standard ISO8643.

Where measurements are critical request certified drawings. We reserve the right to change specifications without notice.

# Versatile, Proven, Best Value

## Sectional Design for Multiple Configurations

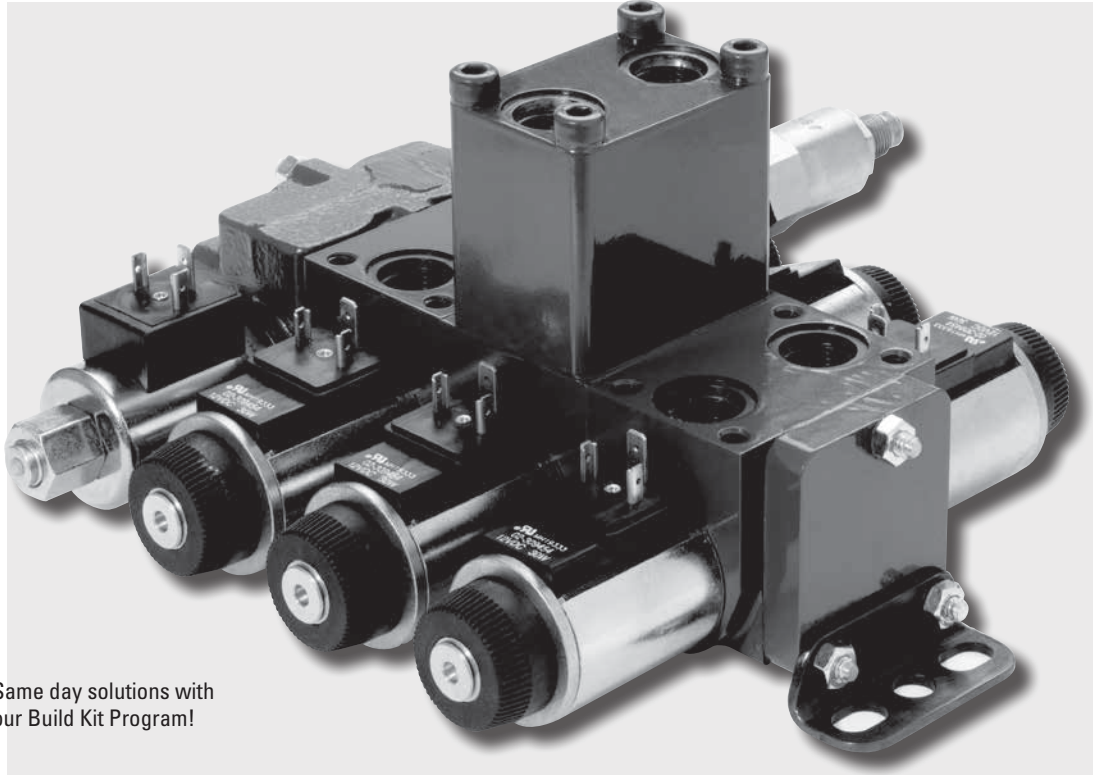

Same day solutions with our Build Kit Program!

**EATON**  
Powering Business Worldwide

### MDG Mobile Valve

Eaton's MDG mobile directional control valve uses a modular, versatile design based on our proven Vickers® DG4V3 design.

Eaton® MDG valves, truly designed for mobile applications, offer the traditional benefits of a stackable mobile valve and provide further value as circuit options for mobile manifold

systems. This same versatility and flexibility applies to system applications, making it your best value for customized, multi-functional circuits.

For more information, contact your local Eaton distributor, call us at 800-547-7805 or visit us on the web at: [www.eaton.com/hydraulics](http://www.eaton.com/hydraulics).

F

# ICE20 - Overcenter Valve

Pilot assisted relief with check

20 L/min (5 USgpm) • 270 bar (4000 psi)

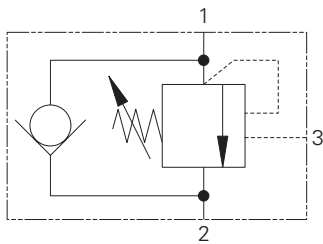

## Sectional View

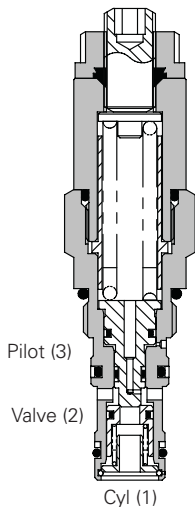

## Operation

The check section allows free flow into the actuator then holds and locks the load against movement. The pilot assisted relief valve section will give controlled movement when pilot pressure is applied. The relief section is normally set to open at a pressure at least 1.3 times the maximum load induced pressure but the pressure required to open the

valve and allow movement depends on the pilot ratio of the valve. For optimization of load control and energy usage, a choice of pilot ratios is available.

The pressure required to open the valve and start actuator movement can be calculated as follows:

$$\text{Pilot Pressure} = \frac{(\text{Relief Setting}) - (\text{Load Pressure})}{\text{Pilot Ratio}}$$

## Features

Cartridge is economical and fits simple cavity. Allows quick, easy field service - reduces down time. Interchangeable with pilot check valve of a similar size.

## Pilot Ratio

3:1 Best suited for extremely unstable applications such as long booms or flexible frameworks.

4.5:1 Best suited for applications where load varies and machine structure can induce instability.

8:1 Best suited for applications where the load remains relatively constant.

## Performance Data

### Ratings and Specifications

Figures based on: Oil Temp = 40° C Viscosity = 32 cSt (150 SUS)

Rated flow	20 L/min (5 USgpm)
Max relief pressure	350 bar (5000 psi)
Max load induced pressure	270 bar (4000 psi)
Cartridge material	Working parts hardened and ground steel. External surfaces zinc plated.
Standard housing material	Aluminum (up to 210 bar). Add suffix "377" for steel option.
Mounting position	Unrestricted
Cavity number	A22903 (See Section M)
Torque cartridge into cavity	40 Nm (30 lbs ft)
Weight	1CE20 0.16 kg (0.35 lbs) 1CE25 0.37 kg (0.82 lbs) 1CEE24 0.41 kg (0.89 lbs)
Seal kit number	SK1276 (Nitrile) SK1276V (Viton®)
Recommended filtration level	BS5540/4 Class 18/13 (25 micron nominal)
Operating temperature	-30°C to +90°C (-22° to +194°F)
Leakage	0.3 milliliters/min nominal (5 dpm)
Nominal viscosity range	5 to 500 cSt

Viton is a registered trademark of E.I. DuPont

## Pressure Drop

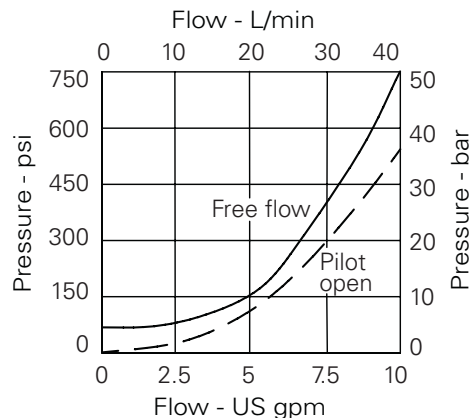

## Description

Overcenter valves give static and dynamic control of loads by regulating the flow into and out of hydraulic actuators. When installed close to or within an actuator, the overcenter valve will stop runaway in the event of hose burst and if open center directional control valves are used, will allow thermal expansion relief of the hydraulic fluid.

The overcenter cartridge is ideal for mounting directly into a cavity machined in the body of the cylinder, motor or rotary actuator. The cartridge can also be mounted directly to the ports via a specifically machined body as part of a Hydraulic Integrated Circuit or single unit, or contained within one of our standard line bodies.

Single overcenter valves are normally used when the load is unidirectional, for example an aerial platform or crane and dual overcenter valves are used for controlling loads in both directional for motor applications or for cylinders going over center.

Where measurements are critical request certified drawings. We reserve the right to change specifications without notice.

# ICE20 - Overcenter Valve

Pilot assisted relief with check  
20 L/min (5 USgpm) • 270 bar (4000 psi)

## Model Code

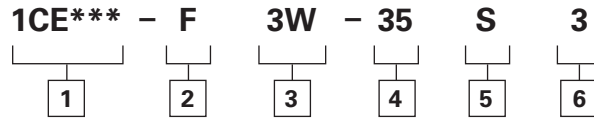

### 1 Basic Code

- 1CE20** - Cartridge Only
- 1CE25** - Cartridge and Body
- 1CEE24** - Cartridges and Dual Body

### 2 Adjustment Means

- F** - Screw Adjustment
- N** - Fixed - State pressure setting required.

For fixed versions add setting in 10 bar increments to end of part number. Subject to a ±10% tolerance.

### 3 Port Sizes

Code	Port Size	Housing Number - Body Only			
		Aluminum Single	Steel Single	Aluminum Dual	Steel Dual
<b>3W</b>	3/8" BSP Valve & Cyl Port. 1/4" BSP Pilot Port	B24255	B24254	B24261	B24260
<b>6T</b>	3/8" SAE Valve & Cyl Port. 1/4" SAE Pilot Port	B24257	B24256	B24264	B24263

### 4 Pressure Range @ 4.8 L/min

**Note:** Code based on pressure in bar.

- 20** - 100-230 bar. Std setting 140 bar
- 35** - 200-350 bar. Std setting 210 bar

Std setting made at 4.8 L/min  
Other pressure ranges available on request

### 5 Seals

- S** - Nitrile (For use with most industrial hydraulic oils)
- SV** - Viton (For high temperature and most special fluid applications)

### 6 Pilot Ratio

- 3** - 3:1
- 4** - 4.5:1
- 8** - 8:1

## Dimensions

mm (inch)

### Cartridge Only

Basic Code  
1CE20

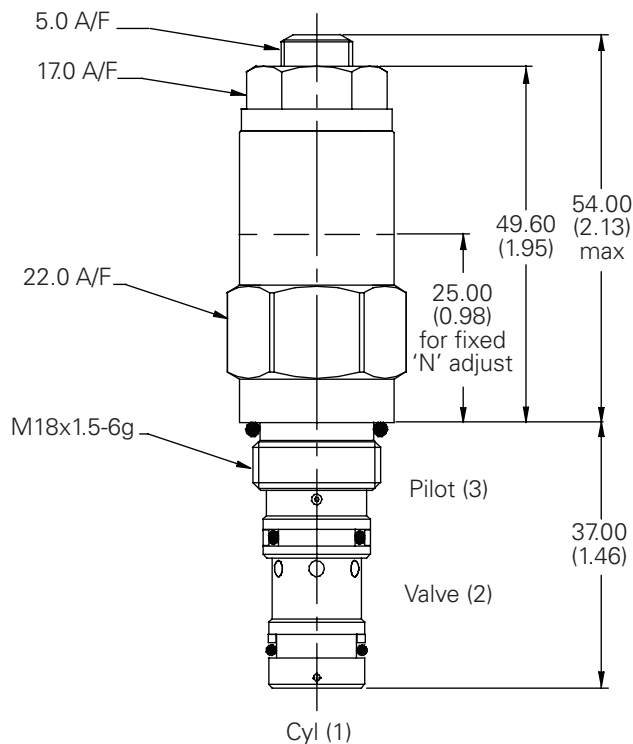

**Note:** For applications above 210 bar - please consult our technical department or use the steel body option.

**Note:** Tightening torque of "F" adjuster locknut - 20 to 25 Nm.

### Single Valve

3/8" Ports  
Basic Code 1CE25

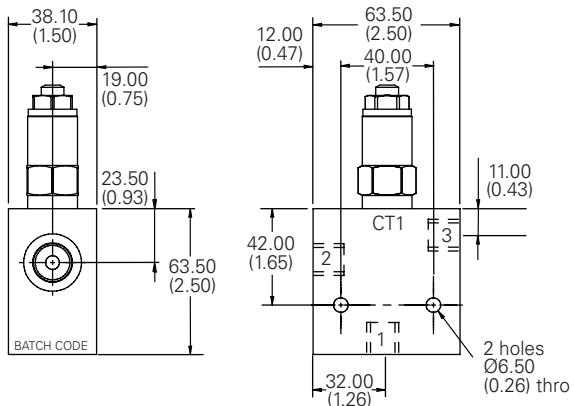

### Dual Valve

3/8" Ports  
Basic Code 1CEE24 (Internally Cross Piloted)

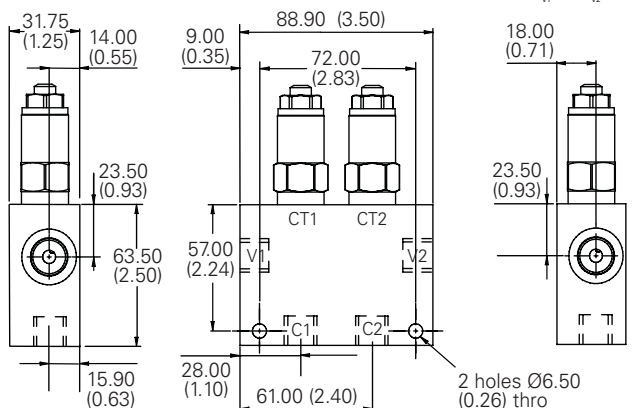

Where measurements are critical request certified drawings. We reserve the right to change specifications without notice.

# ICE30 - Overcenter Valve

Pilot assisted relief with check

30L/min (8 USgpm) • 270 bar (4000 psi)

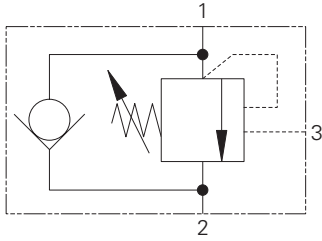

## Sectional View

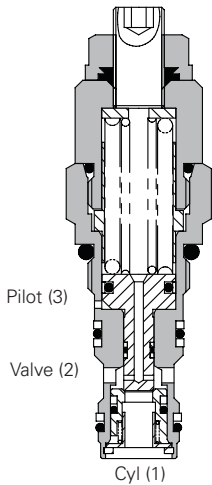

F

## Description

Overcenter valves give static and dynamic control of loads by regulating the flow into and out of hydraulic actuators. When installed close to or within an actuator, the overcenter valve will stop runaway in the event of hose burst and if open center directional control valves are used, will allow thermal expansion relief of the hydraulic fluid.

The overcenter cartridge is ideal for mounting directly into a cavity machined in the body of the cylinder, motor or rotary actuator. The cartridge can also be mounted directly to the ports via a specifically machined body as part of a Hydraulic Integrated Circuit or single unit, or contained within one of our standard line bodies.

Single overcenter valves are normally used when the load is unidirectional, for example an aerial platform or crane and dual overcenter valves are used for controlling loads in both directional for motor applications or for cylinders going over center.

Where measurements are critical request certified drawings. We reserve the right to change specifications without notice.

## Operation

The check section allows The check section allows free flow into the actuator then holds and locks the load against movement. The pilot assisted relief valve section will give controlled movement when pilot pressure is applied. The relief section is normally set to open at a pressure at least 1.3 times the maximum load induced pressure but the pressure required to open the

valve and allow movement depends on the pilot ratio of the valve. For optimization of load control and energy usage, a choice of pilot ratios is available.

The pressure required to open the valve and start actuator movement can be calculated as follows:

$$\text{Pilot Pressure} = \frac{(\text{Relief Setting}) - (\text{Load Pressure})}{\text{Pilot Ratio}}$$

## Features

Cartridge is economical and fits simple cavity. Allows quick, easy field service - reduces down time. Interchangeable with pilot check valve of a similar size.

## Pilot Ratio

2.5:1 Best suited for extremely unstable applications such as long booms or flexible frameworks.

5:1 (standard) Best suited for applications where load varies and machine structure can induce instability.

10:1 Best suited for applications where the load remains relatively constant.

## Performance Data

### Ratings and Specifications

Figures based on: Oil Temp = 40° C Viscosity = 32 cSt (150 SUS)

Rated flow	30 L/min (8 USgpm)
Max relief pressure	350 bar (5000 psi)
Max load induced pressure	270 bar (4000 psi)
Cartridge material	Working parts hardened and ground steel. External surfaces zinc plated.
Standard housing material	Aluminum (up to 210 bar). Add suffix "377" for steel option.
Mounting position	Unrestricted
Cavity	A6610 (See Section M)
Torque cartridge into cavity	45 Nm (33 lbs ft)
Weight	1CE30 0.15 kg (0.33 lbs) 1CE35 0.41 kg (0.90 lbs) 1CEE34 0.90 kg (1.98 lbs)
Seal kits	SK395 (Nitrile) SK395V (Viton®)
Filtration	Cleanliness code 18/13 (25 micron nominal)
Temperature range	-30°C to +90°C (-22° to +194°F)
Internal leakage	0.3 milliliters/min nominal (5 dpm)
Nominal viscosity range	5 to 500 cSt

Viton is a registered trademark of E.I. DuPont

## Pressure Drop

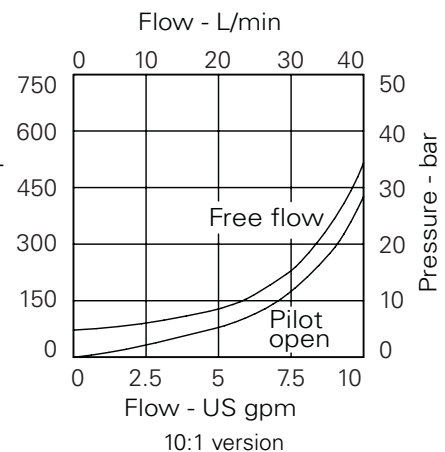
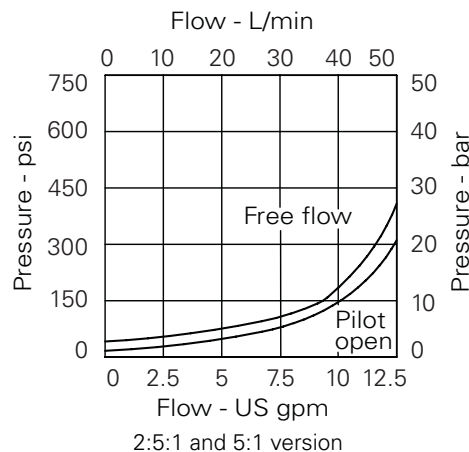

# ICE30 - Overcenter Valve

Pilot assisted relief with check  
30L/min (8 USgpm) • 270 bar (4000 psi)

## Model Code

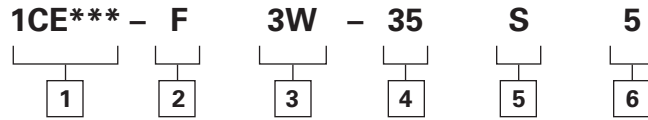

### 1 Function

**1CE30** - Cartridge Only  
**1CE35** - Cartridge in body  
**1CEE34** - Cartridges in dual body

### 2 Adjustment

**F** - Screw adjustment  
**N** - Fixed

For fixed versions add setting in 10 bar increments to end of part number. Subject to a +/-10% tolerance.

### 3 Port Size

Code	Port Size	Housing Number - Body Only			
		Aluminum Single	Steel Single	Aluminum Dual	Steel Dual
<b>3W</b>	3/8" BSPP	B6743	B12823	B6836	B13803
<b>6T</b>	3/8" SAE	B10536		B10805	
<b>8T</b>	1/2" SAE	B7884		B30237	

### 4 Pressure Range

**Note:** Code based on pressure in bar.  
**20** - (2.5:1 and 5:1): 70-210 bar.  
Std setting 100 bar (10:1): 100-210 bar. Std setting 100 bar  
**35** - (2.5:1 and 5:1): 100-350 bar.  
Std setting 210 bar (10:1): 120-350 bar. Std setting 210 bar

### 5 Seal Material

**S** - Buna-N  
**SV** - Viton

### 6 Pilot Ratio

**2** - 2:1  
**5** - 5:1  
**10** - 10:1

## Dimensions

mm (inch)

### Cartridge Only

Basic Code  
1CE30

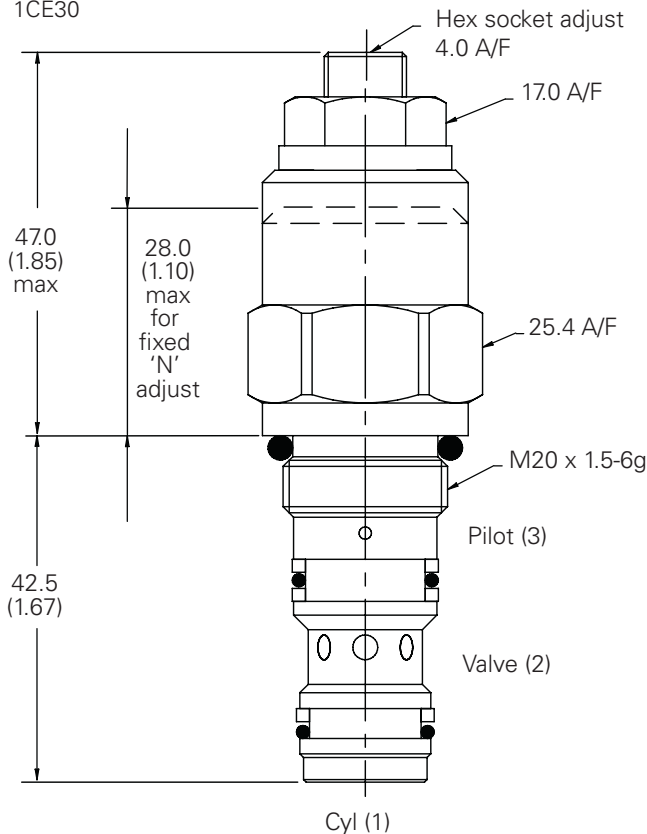

**Note:** For applications above 210 bar - please consult our technical department or use the steel body option

**Note:** Tightening torque of "F" adjuster locknut - 20 to 25 Nm

### Single Valve with Housing

Basic Code  
1CE35

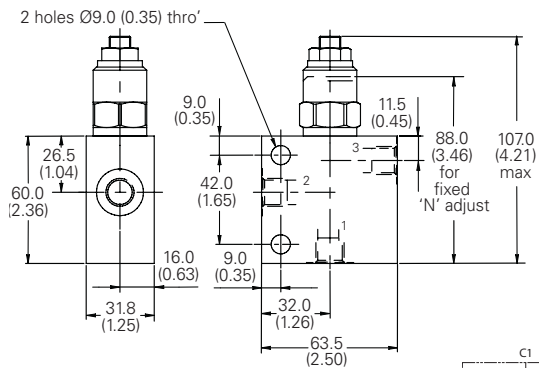

### Double Valve with Housing

Basic Code  
1CEE34

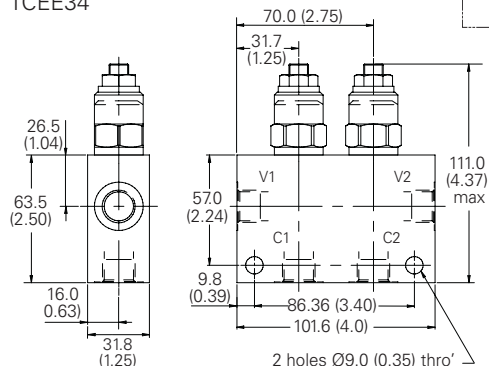

Where measurements are critical request certified drawings. We reserve the right to change specifications without notice.

# ICEH30 - High Pressure Overcenter Valve

Pilot assisted relief with check

30L/min (8 USgpm) • 350 bar (5000 psi)

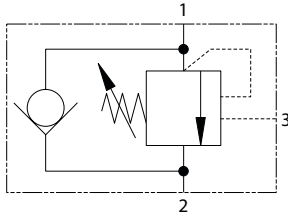

## Sectional View

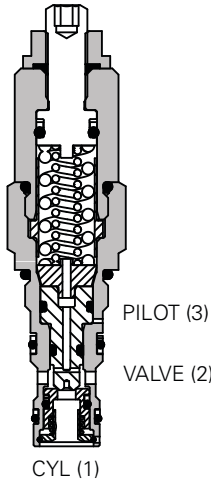

F

## Description

Overcenter valves give static and dynamic control of loads by regulating the flow into and out of hydraulic actuators. When installed close to or within an actuator, the overcenter valve will stop runaway in the event of hose burst and if open center directional control valves are used, will allow thermal expansion relief of the hydraulic fluid.

The overcenter cartridge is ideal for mounting directly into a cavity machined in the body of the cylinder, motor or rotary actuator. The cartridge can also be mounted directly to the ports via a specifically machined body as part of a Hydraulic Integrated Circuit or single unit, or contained within one of our standard line bodies.

Single overcenter valves are normally used when the load is unidirectional, for example an aerial platform or crane and dual overcenter valves are used for controlling loads in both directional for motor applications or for cylinders going over center.

## Operation

The check section allows free flow into the actuator then holds and locks the load against reverse movement. The pilot assisted relief valve section will give controlled movement when pilot pressure is applied. The relief section is normally set to open at a pressure at least 1.3 times the maximum load induced pressure but the pressure required to open the

valve and allow movement depends on the pilot ratio of the valve. For optimization of load control and energy usage, a choice of pilot ratios is available.

The pressure required to open the valve and start actuator movement can be calculated as follows:

$$\text{Pilot Pressure} = \frac{(\text{Relief Setting}) - (\text{Load Pressure})}{\text{Pilot Ratio}}$$

## Features

Cartridge is economical and fits simple cavity. Allows quick, easy field service - reduces down time. Interchangeable with pilot check valve of a similar size.

Dynamic seals on the internal moving parts to provide longer fatigue life.

## Pilot Ratio

3:1 Best suited for extremely unstable applications such as long booms or flexible frameworks.

5:1 (standard) Best suited for applications where load varies and machine structure can induce instability.

## Performance Data

### Ratings and Specifications

Figures based on: Oil Temp = 40° C Viscosity = 32 cSt (150 SUS)

Rated flow	30 L/min (8 USgpm)
Max relief pressure	430 bar (6240 psi)
Max load induced pressure	350 bar (5000 psi)
Cartridge material	Working parts hardened and ground steel. External surfaces zinc plated.
Standard housing material	Steel. Add suffix "377"
Mounting position	Unrestricted
Cavity	A6610 (See Section M)
Torque cartridge into cavity	68-75 Nm (50-56 lbs ft)
Weight	1CEH30 0.25 kg (0.55 lbs) 1CEH35 0.51 kg (1.12 lbs) 1CEEH34 1 kg (2.2 lbs)
Seal kits	9900925-000 (Nitrile) 9900926-000 (Viton®)
Filtration	Cleanliness code 18/13 (25 micron nominal)
Temperature range	-30°C to +90°C (-22° to +194°F)
Internal leakage	5 dpm - Leakage at 85% of Crack Pressure
Nominal viscosity range	5 to 500 cSt

Viton is a registered trademark of E.I. DuPont

## Pressure Drop

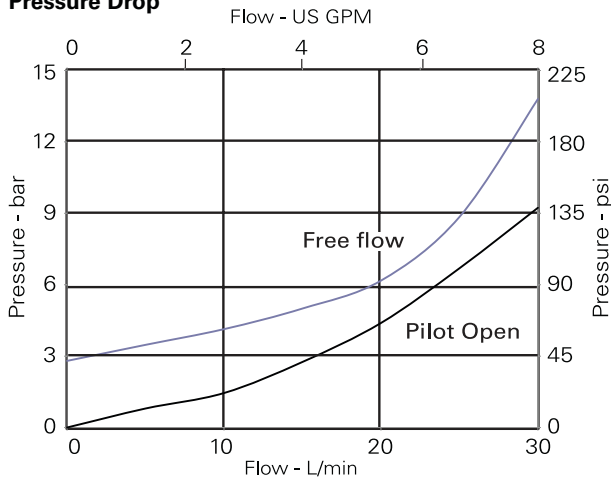

3:1 and 5:1 version

Where measurements are critical request certified drawings. We reserve the right to change specifications without notice.

# ICEH30 - High Pressure Overcenter Valve

Pilot assisted relief with check

30L/min (8 USgpm) • 350 bar (5000 psi)

## Model Code

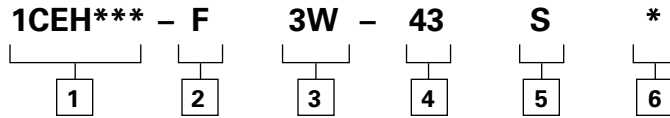

### 1 Function

1CEH30 - Cartridge Only  
 1CEH35 - Cartridge in body  
 1CEEH34 - Cartridges in dual body

### 2 Adjustment

F - Screw adjustment

### 3 Port Size

Code	Port Size	Housing Number - Body Only	
		Steel Single	Steel Dual
3W	3/8" BSPP	B12823	B13803
8T	1/2" SAE	B11811	B11812

### 4 Pressure Range

**Note:** Code based on pressure in bar.

43 - (3:1 and 5:1): 250-430 bar.

Std setting 350 bar.

Std setting made at 1 L/min

**Note:** Contact CSR for special pressure setting.

### 5 Seal Material

S - Buna-N

SV - Viton

### 6 Pilot Ratio

3 - 3:1

5 - 5:1

## Dimensions

mm (inch)

## Cartridge Only

Basic Code

1CEH30

**Note:** Tightening torque of "F" adjuster locknut - 20 to 25 Nm

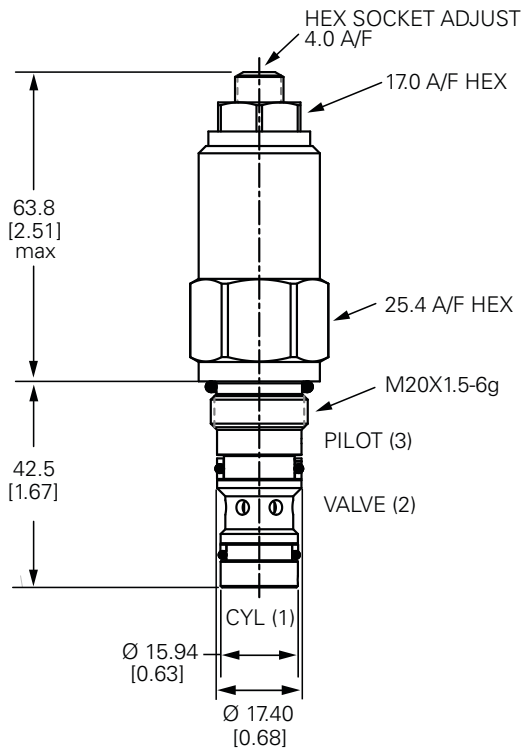

## Single Valve with Housing

Basic Code

1CEH35

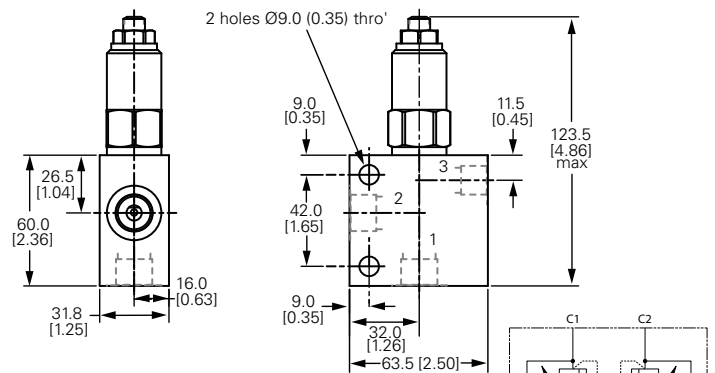

## Double Valve with Housing

Basic Code

1CEEH34

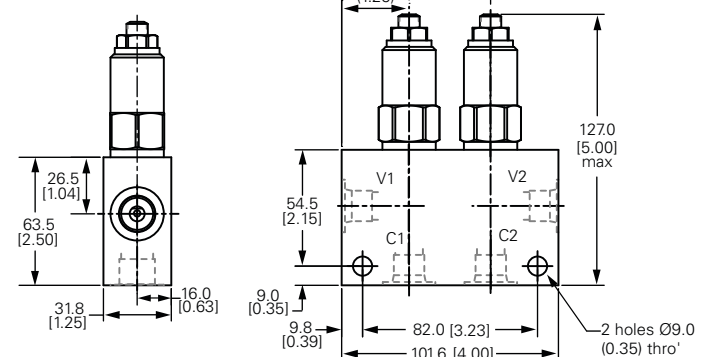

Where measurements are critical request certified drawings. We reserve the right to change specifications without notice.

# 1CER30 - Overcenter Valve

Part balanced, pilot assisted relief with check  
30 L/min (8 USgpm) • 270 bar (4000 psi)

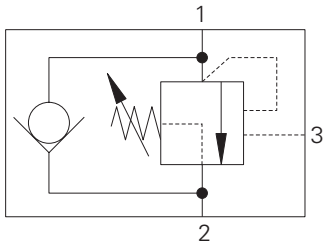

## Operation

The check section allows free flow into the actuator then holds and locks the load against movement. The pilot assisted relief valve section will give controlled movement when pilot pressure is applied. The relief section is normally set to open at a pressure at least 1.3 times the maximum load induced pressure but the pressure required to open the

valve and allow movement depends on the pilot ratio of the valve. For optimization of load control and energy usage, a choice of pilot ratios is available.

The pressure required to open the valve and start actuator movement can be calculated as follows:

$$\text{Pilot Pressure} = \frac{(\text{Relief Setting}) - (\text{Load Pressure})}{\text{Pilot Ratio}}$$

## Features

Cartridge is economical and fits simple cavity. Allows quick, easy field service - reduces down time. Interchangeable with pilot check valve of a similar size.

## Pilot Ratio

2.5:1 Best suited for extremely unstable applications such as long booms or flexible frameworks.

4:1 Best suited for applications where load varies and machine structure can induce instability.

## Sectional View

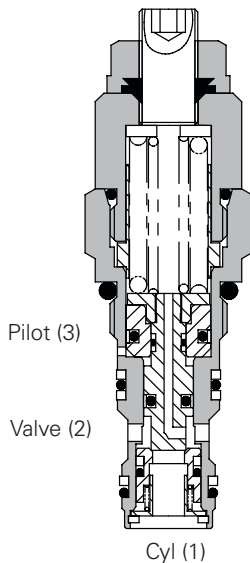

F

## Performance Data

### Ratings and Specifications

Figures based on: Oil Temp = 40° C Viscosity = 32 cSt (150 SUS)

Rated flow	30 L/min (8 USgpm)
Max relief pressure	350 bar (5000 psi)
Max load induced pressure	270 bar (4000 psi)
Cartridge material	Working parts hardened and ground steel. External surfaces zinc plated.
Standard housing material	Aluminum (up to 210 bar). Add suffix "377" for steel option.
Mounting position	Unrestricted
Cavity	A6610 (See Section M)
Torque cartridge into cavity	45 Nm (33 lbs ft)
Weight	1CER30 0.15 kg (0.33 lbs) 1CER35 0.41 kg (0.90 lbs) 1CEER34 0.90 kg (1.98 lbs)
Seal kits	SK395 (Nitrile) SK395V (Viton®)
Filtration	Cleanliness code 18/13 (25 micron nominal)
Temperature range	-30°C to +90°C (-22° to +194°F)
Internal leakage	0.3 milliliters/min nominal (5 dpm)
Nominal viscosity range	5 to 500 cSt

Viton is a registered trademark of E.I. DuPont

## Description

The 1CER series overcenter valve performs all duties of a regular overcenter but is able to relieve and stay open irrespective of downstream pressure. This enables the valve to operate when used with a closed center directional valve which has service line reliefs. The poppet is pressure balanced, preventing relief setting increase due to back pressure.

## Pressure Drop

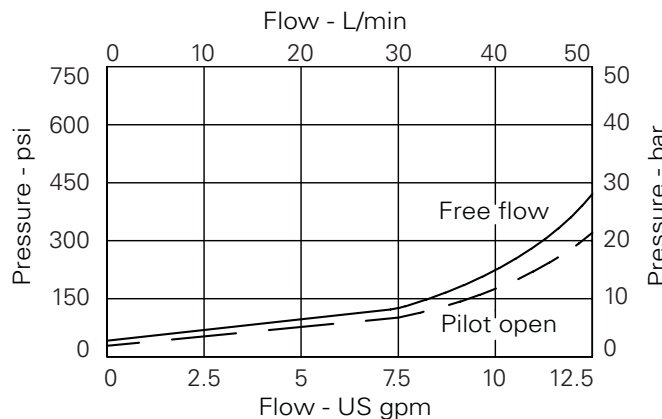

Where measurements are critical request certified drawings. We reserve the right to change specifications without notice.

# 1CER30 - Overcenter Valve

Part balanced, pilot assisted relief with check  
30 L/min (8 USgpm) • 270 bar (4000 psi)

## Model Code

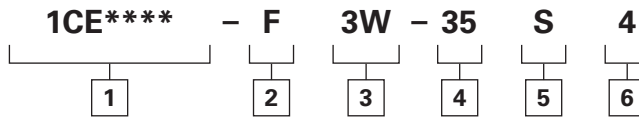

### 1 Basic Code

**1CER30** - Cartridge only  
**1CER35** - Cartridge and body  
**1CEER34** - Cartridges and dual body

### 2 Adjustment

**F** - Screw adjustment  
**N** - Fixed - State pressure setting required.

For fixed versions add setting in 10 bar increments to end of part number. Subject to a  $\pm 10\%$  tolerance.

### 3 Port Sizes - Bodied Valves Only

Code	Port Size	Housing Number			
		Aluminum Single	Steel Single	Aluminum Dual	Steel Dual
Body Only					
<b>3W</b>	3/8" BSP Valve & Cyl Port 1/4" BSP Pilot Port	B6743	B12823	B6836	B13803
<b>6T</b>	3/8" SAE Valve & Cyl Port 1/4" SAE Pilot Port	B10536		B10805	
<b>8T</b>	1/2" SAE Valve & Cyl Port 1/4" SAE Pilot Port	B7884	B11811	B30237	B11812

### 4 Pressure Range @ 4.8 L/min

**Note:** Code based on pressure in bar.  
**35** - 100-350 bar.  
Std setting 210 bar  
Std setting made at 4.8 L/min

### 5 Seals

**S** - Nitrile  
**SV** - Viton

### 6 Pilot Ratio

**2** - 2.5:1  
**4** - 4:1

## Dimensions

mm (inch)

### Cartridge Only

Basic Code  
1CER30

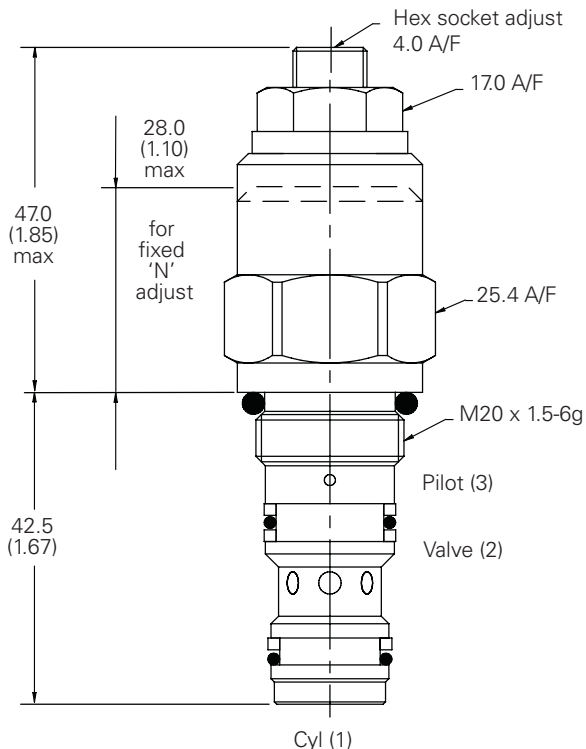

**Note:** For applications above 210 bar - please consult our technical department or use the steel body option

**Note:** Tightening torque of "F" adjuster locknut - 20 to 25 Nm

### Single Valve

3/8". 1/2" Ports  
Basic Code 1CER35

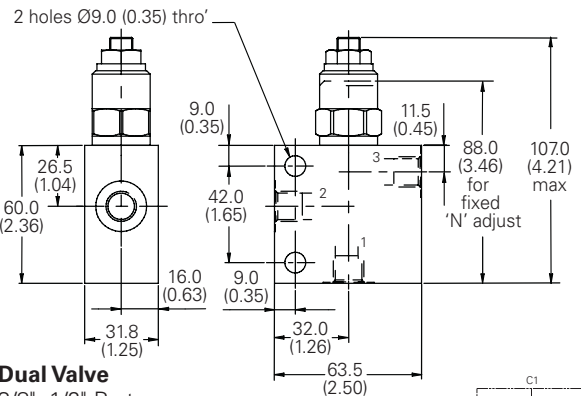

### Dual Valve

3/8". 1/2" Ports  
Basic Code 1CEER34  
(Internally Cross Piloted)

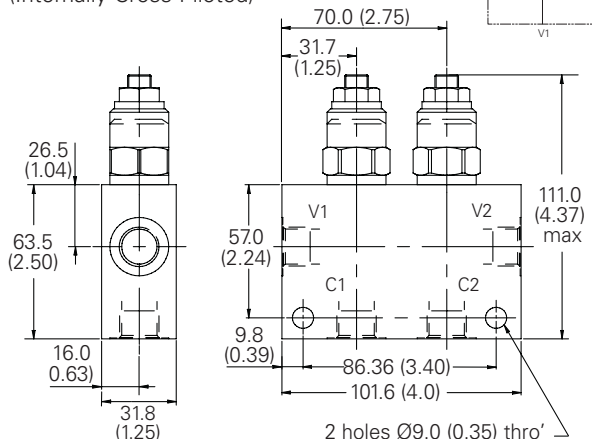

Where measurements are critical request certified drawings. We reserve the right to change specifications without notice.

# 1CERH30 - High Pressure Overcenter Valve

Part balanced, pilot assisted relief with check

30 L/min (8 USgpm) • 350 bar (5000 psi)

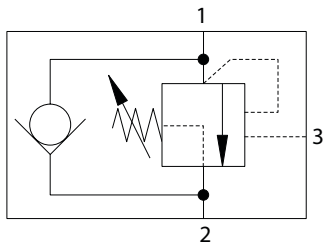

## Operation

The check section allows free flow into the actuator then holds and locks the load against movement. The pilot assisted relief valve section will give controlled movement when pilot pressure is applied. The relief section is normally set to open at a pressure at least 1.3 times the maximum load induced pressure but the pressure required to open the

valve and allow movement depends on the pilot ratio of the valve. For optimization of load control and energy usage, a choice of pilot ratios is available.

The pressure required to open the valve and start actuator movement can be calculated as follows:

$$\text{Pilot Pressure} = \frac{(\text{Relief Setting}) - (\text{Load Pressure})}{\text{Pilot Ratio}}$$

## Features

Cartridge is economical and fits simple cavity. Allows quick, easy field service - reduces down time. Interchangeable with pilot check valve of a similar size.

## Pilot Ratio

3:1 Best suited for extremely unstable applications such as long booms or flexible frameworks.

5:1 Best suited for applications where load varies and machine structure can induce instability.

## Sectional View

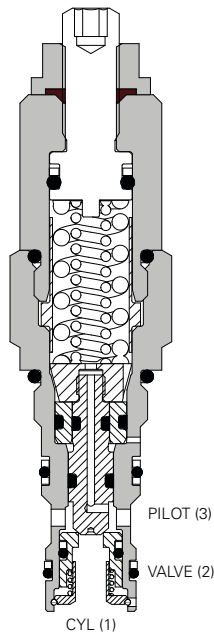

## Performance Data

### Ratings and Specifications

Figures based on: Oil Temp = 40° C Viscosity = 32 cSt (150 SUS)

Rated flow	30 L/min (8 USgpm)	
Max relief pressure	430 bar (6240 psi)	
Max load induced pressure	350 bar (5000 psi)	
Cartridge material	Working parts hardened and ground steel. External surfaces zinc plated.	
Standard housing material	Steel. Add suffix "377"	
Mounting position	Unrestricted	
Cavity	A6610 (See Section M)	
Torque cartridge into cavity	68-75 Nm (50-56 lbs ft)	
Weight	1CERH30	0.2 kg (0.55 lbs)
	1CERH35	0.51 kg (1.12 lbs)
	1CEERH34	1.0 kg (2.2 lbs)
Seal kits	9900925-000	(Nitrile)
	9900926-000	(Viton®)
Filtration	Cleanliness code 18/13 (25 micron nominal)	
Temperature range	-30°C to +90°C (-22° to +194°F)	
Internal leakage	5 dpm @ 85% of Cracking	
Nominal viscosity range	5 to 500 cSt	

Viton is a registered trademark of E.I. DuPont

## Description

The 1CERH series overcenter valve performs all duties of a regular overcenter but is able to relieve and stay open irrespective of downstream pressure. This enables the valve to operate when used with a closed center directional valve which has service line reliefs. The poppet is pressure balanced, preventing relief setting increase due to back pressure.

## Pressure Drop

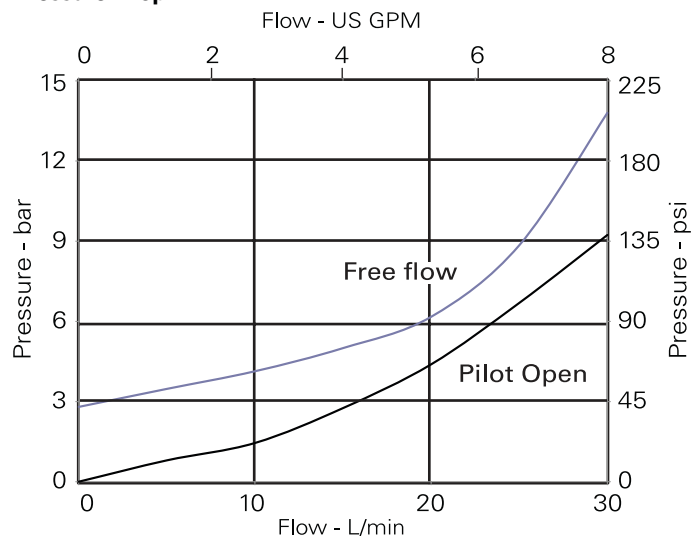

3:1 and 5:1 version

Where measurements are critical request certified drawings. We reserve the right to change specifications without notice.

# 1CERH30 - High Pressure Overcenter Valve

Part balanced, pilot assisted relief with check  
 30 L/min (8 USgpm) • 350 bar (5000 psi)

## Model Code

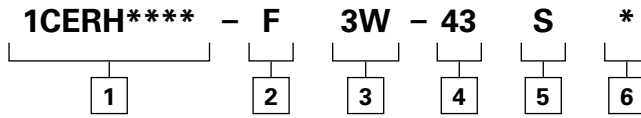

### 1 Basic Code

1CERH30 - Cartridge only  
 1CERH35 - Cartridge and body  
 1CEERH34 - Cartridges and dual body

### 2 Adjustment

F - Screw adjustment

### 3 Port Sizes - Bodied Valves Only

Code	Port Size	Housing Number	
		Steel Single	Steel Dual
<b>Body Only</b>			
3W	3/8" BSP Valve & Cyl Port 1/4" BSP Pilot Port	B12823	B13803
8T	1/2" SAE Valve & Cyl Port 1/4" SAE Pilot Port	B11811	B11812

### 4 Pressure Range

**Note:** Code based on pressure in bar.

43 - 250-430 bar. Std setting 350 bar  
 Std setting made at 1 L/min

**Note:** Contact CSR for special pressure setting.

**Note:** Tightening torque of "F" adjuster locknut - 20 to 25 Nm

### 5 Seals

S - Nitrile  
 SV - Viton

### 6 Pilot Ratio

3 - 3:1  
 5 - 5:1

## Dimensions

mm (inch)

### Cartridge Only

Basic Code  
 1CERH30

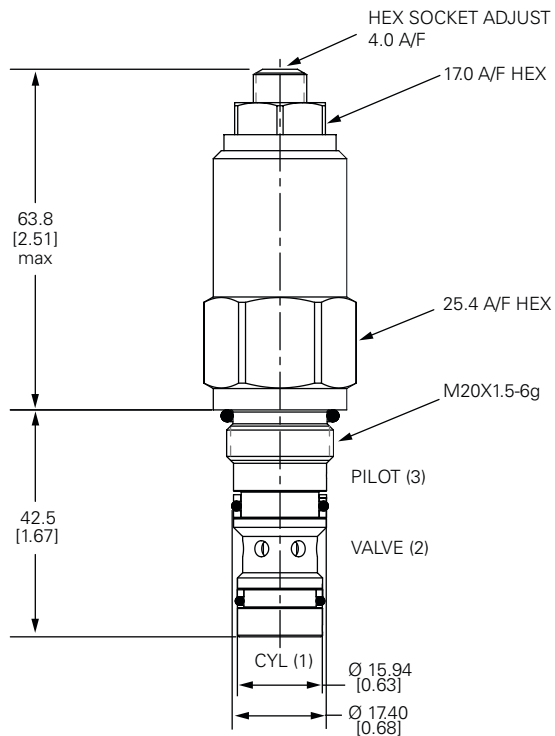

### Single Valve

3/8", 1/2" Ports  
 Basic Code 1CERH35

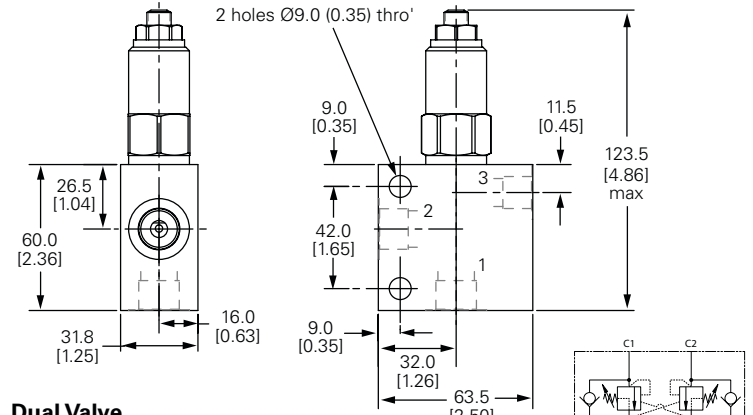

### Dual Valve

3/8", 1/2" Ports  
 Basic Code 1CEERH34  
 (Internally Cross Piloted)

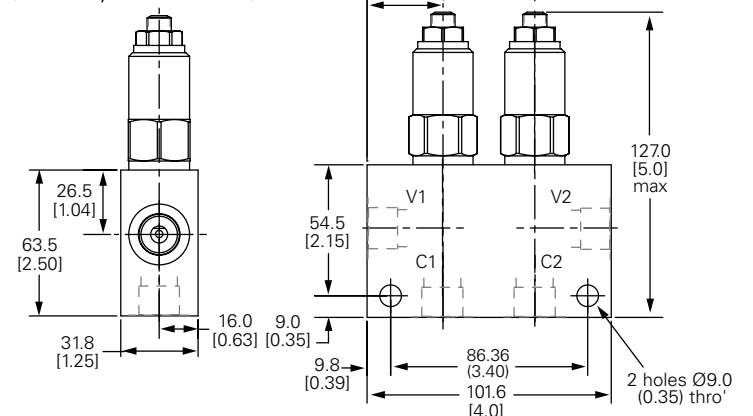

Where measurements are critical request certified drawings. We reserve the right to change specifications without notice.

# ICEB30 - Overcenter Valve

Fully balanced, pilot assisted, relief with check  
30 L/min (8 USgpm) • 270 bar (4000 psi)

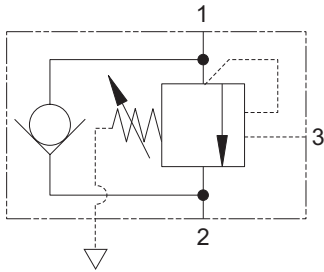

## Sectional View

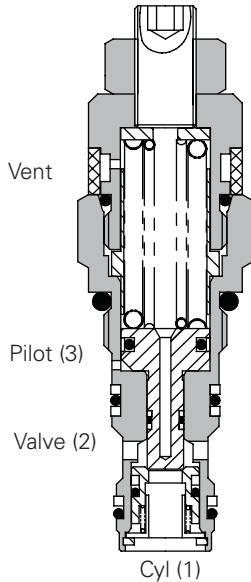

## Description

Overcenter valves give static and dynamic control of loads by supplying a counterbalance pressure to the actuator. They prevent runaway in the event of hose burst and hold the load with minimal leakage.

The pressure balanced valve is unaffected by back pressure, allowing service line reliefs to operate and for the valve to be used in regenerative or proportional valve systems.

The overcenter valve should be mounted either into, onto or as close to the actuator as possible to give maximum protection.

Single overcenter valves control unidirectional loads such as in aerial platforms, cranes or winches and dual overcenters are suited to bi-directional motion such as wheel motor applications or cylinders going over center.

## Operation

The check section allows free flow into the actuator then holds and locks the load against movement. The pilot assisted relief valve section will give controlled movement when pilot pressure is applied. The relief section is normally set to open at a pressure at least 1.3 times the maximum load induced pressure but the pressure required to open the

valve and allow movement depends on the pilot ratio of the valve. For optimization of load control and energy usage, a choice of pilot ratios is available.

The pressure required to open the valve and start actuator movement can be calculated as follows:

$$\text{Pilot Pressure} = \frac{(\text{Relief Setting}) - (\text{Load Pressure})}{\text{Pilot Ratio}}$$

## Features

Cartridge is economical and fits simple cavity. Allows quick, easy field service - reduces down time. Interchangeable with pilot check valve of a similar size.

## Pilot Ratio

5.1:1 (standard) Best suited for applications where load varies and machine structure can induce instability.

**Note:** This valve is not suitable for high frequency applications and aggressive environmental conditions.

## Performance Data

### Ratings and Specifications

Figures based on: Oil Tem = 40°C Viscosity = 32 cSt (150 SUS)

Rated flow	30 L/min (8 USgpm)
Max relief pressure	300 bar (350 psi)
Max load induced pressure	270 bar (4000 psi)
Cartridge material	Working parts hardened and ground steel. External surfaces zinc plated.
Standard housing material	Aluminum (up to 210 bar). Add suffix "377" for steel option.
Mounting position	Unrestricted
Cavity number	A6610 (See Section M)
Torque cartridge into cavity	45 Nm (33 lbs ft)
Weight	1CEB30 0.14 kg (0.30 lbs) 1CEB35 0.40 kg (0.88 lbs) 1CEEB34 0.88 kg (1.94 lbs)
Seal kit number	SK395 (Nitrile) SK395V (Viton®)
Recommended filtration level	BS5540/4 Class 18/13 (25 micron nominal)
Operating temperature	-30°C to +90°C (-22° to +194°F)
Leakage	0.3 milliliters/min nominal (5 dpm)
Nominal viscosity range	5 to 500 cSt

Viton is a registered trademark of E.I. DuPont

## Pressure Drop

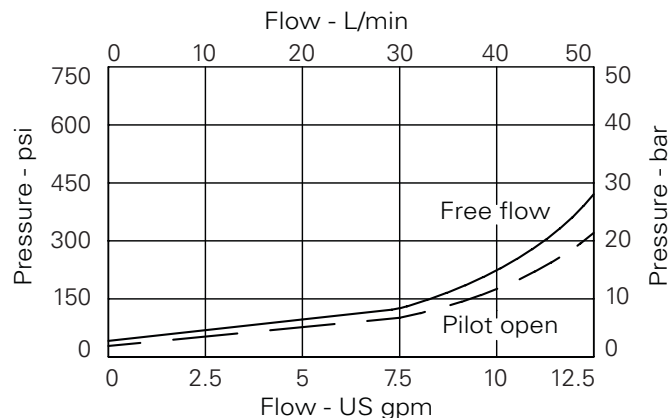

Where measurements are critical request certified drawings. We reserve the right to change specifications without notice.

# 1CEB30 - Overcenter Valve

Fully balanced, pilot assisted, relief with check  
30 L/min (8 USgpm) • 270 bar (4000 psi)

## Model Code

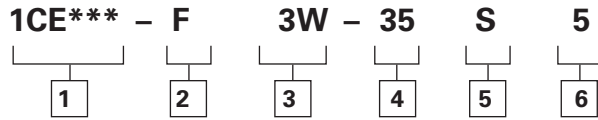

### 1 Function

- 1CEB30** - Cartridge Only
- 1CEB35** - Cartridge and Body
- 1CEEB34** - Cartridges and Dual Body

### 2 Adjustment Means

- F** - Screw Adjustment
- N** - Fixed - State pressure setting required.

For fixed versions add setting in 10 bar increments to end of part number. Subject to a ±10% tolerance.

### 3 Port Sizes

Code	Port Size	Housing Number - Body Only			
		Aluminium Single	Steel Single	Aluminium Dual	Steel Dual
<b>3W</b>	3/8" BSP Valve & Cyl Port 1/4" BSP Pilot Port	B6743	B12823	B6836	B13803
<b>6T</b>	3/8" SAE Valve & Cyl Port 1/4" SAE Pilot Port	B10536		B10805	
<b>8T</b>	1/2" SAE Valve & Cyl Port 1/4" SAE Pilot Port	B7884	B11811	B30237	B11812

### 4 Pressure Range @ 4.8 L/min

**Note:** Code based on pressure in bar.

**35** - 100-350 bar.  
Std setting 210 bar  
Std setting made at 4.8 L/min

### 5 Seals

- S** - Nitrile (For use with most industrial hydraulic oils)
- SV** - Viton (For high temperature and most special fluid applications)

### 6 Pilot Ratio

**5** - 5:1

## Dimensions

mm (inch)

### Cartridge Only

Basic Code

**1CEB30**

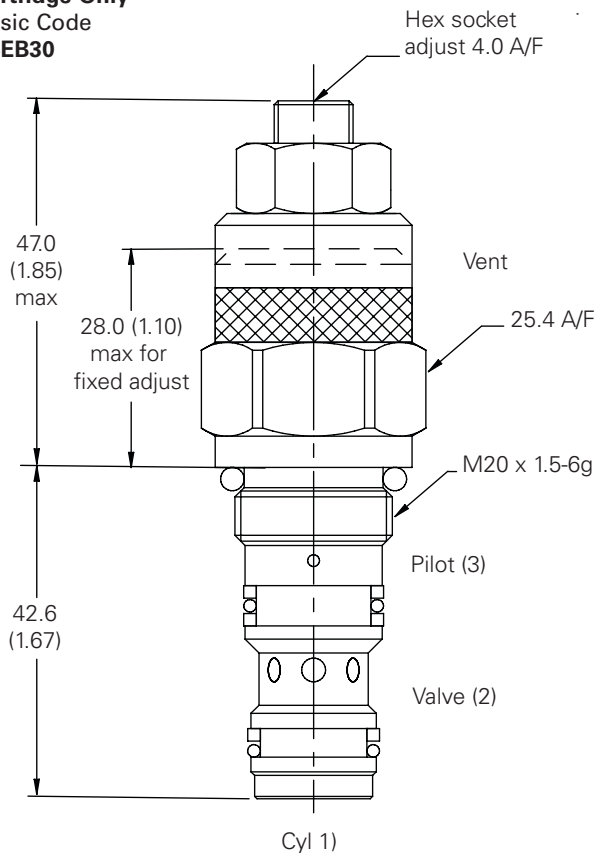

**Note:** For applications above 210 bar - please consult our technical department or use the steel body option

**Note:** Tightening torque of "F" adjuster locknut - 20 to 25 Nm

### Single Valve

3/8". 1/2" Ports

Basic Code

**1CEB35**

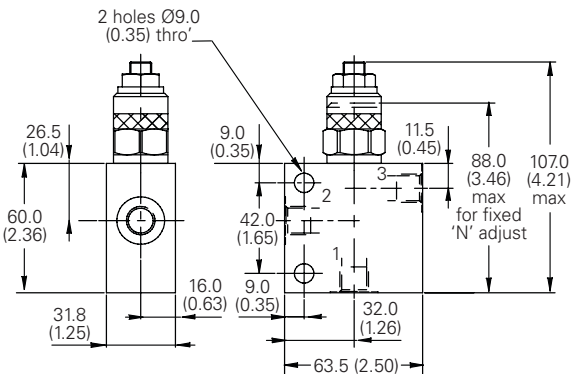

### Dual Valve

3/8". 1/2" Ports

Basic Code

**1CEEB34**

Internally Cross Piloted

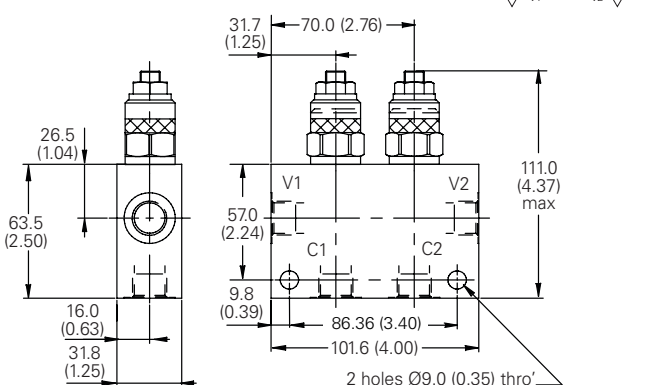

Where measurements are critical request certified drawings. We reserve the right to change specifications without notice.

# ICEBD30 - Overcenter Valve

Fully balanced, pilot assisted relief  
30 L/min (8 USgpm) • 270 bar (4000 psi)

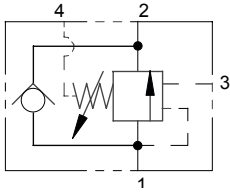

## Sectional View

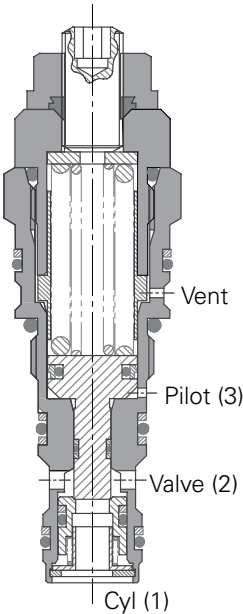

## Description

Overcenter valves give static and dynamic control of loads by supplying a counterbalance pressure to the actuator. They prevent runaway in the event of hose burst and hold the load with minimal leakage.

The pressure balanced valve is unaffected by back pressure, allowing service line reliefs to operate and for the valve to be used in regenerative or proportional valve systems.

The overcenter valve should be mounted either into, onto or as close to the actuator as possible to give maximum protection.

Single overcenter valves control unidirectional loads such as in aerial platforms, cranes or winches and dual overcenters are suited to bi-directional motion such as wheel motor applications or cylinders going over center.

## Operation

The check section allows free flow into the actuator then holds and locks the load against movement. The pilot assisted relief valve section will give controlled movement when pilot pressure is applied. The relief section is normally set to open at a pressure at least 1.3 times the maximum load induced pressure but the pressure required to open the valve and allow movement depends on the pilot ratio of the valve.

For optimization of load control and energy usage, a choice of pilot ratios is available.

The pressure required to open the valve and start actuator movement can be calculated as follows:

$$\text{Pilot Pressure} = \frac{(\text{Relief Setting}) - (\text{Load Pressure})}{\text{Pilot Ratio}}$$

## Features

Cartridge is economical and fits simple 'dual purpose' cavity. Allows quick, easy field service - reduces down time. Directly interchangeable with 30 litres/min pilot check valve.

## Pilot Ratio

5:1

## Performance Data

### Ratings and Specifications

Figures based on Oil Temp = 40°C Viscosity = 32 cSt (150 SUS)

Rated flow	30 L/min (8 USgpm)
Max relief setting	350 bar (5000 psi)
Max load induced pressure*	270 bar (4000 psi)
Cartridge material	Working parts hardened and ground steel. External surfaces zinc plated.
Mounting position	Unrestricted
Cavity	A20530 (See section M)
Torque cartridge into cavity	45 Nm (33 lbs ft)
Weight	0.14 kg (0.30 lbs)
Seal kit	SK1159 (Nitrile) SK1159V (Viton®) SK634P (Polyurethane/Nitrile)
Filtration	BS5540/4 Class 18/13 (25 micron nominal)
Temperature range	-20° to +90°C (-4° to +194°F)
Leakage	0.3 milliliters/min (5 dpm)
Nominal viscosity range	5 to 500 cSt

Viton is a registered trademark of E.I. DuPont

\*For applications above 210 bar please consult our technical department or use the steel body option.

## Pressure Drop

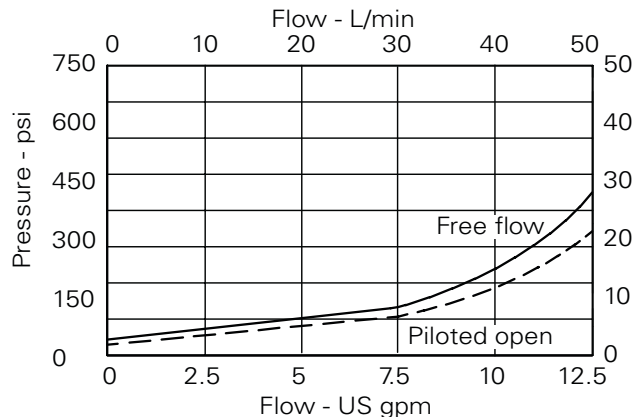

Where measurements are critical request certified drawings. We reserve the right to change specifications without notice.

# 1CEBD30 - Overcenter Valve

Fully balanced, pilot assisted relief

30 L/min (8 USgpm) • 270 bar (4000 psi)

Model Code

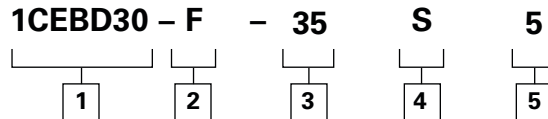

**1 Function**  
1CEBD30 - Cartridge Only

**2 Adjustment Means**  
F - Screw adjustment

**3 Pressure Range @ 4.8 L/min**  
**Note:** Code based on pressure in bar.  
20 - 70-210 bar  
Standard setting 100 bar  
35 - 100-350 bar  
Standard setting 210 bar  
Standard setting made at 4.8 L/min

**4 Seals**  
**S** - Nitrile (for use with most industrial hydraulic oils)  
**SV** - Viton (for high temperature and most special fluid applications)

**5 Pilot Ratio**  
5 - 5:1

## Dimensions

mm (inch)

### Cartridge Only

Basic Code  
1CEBD30

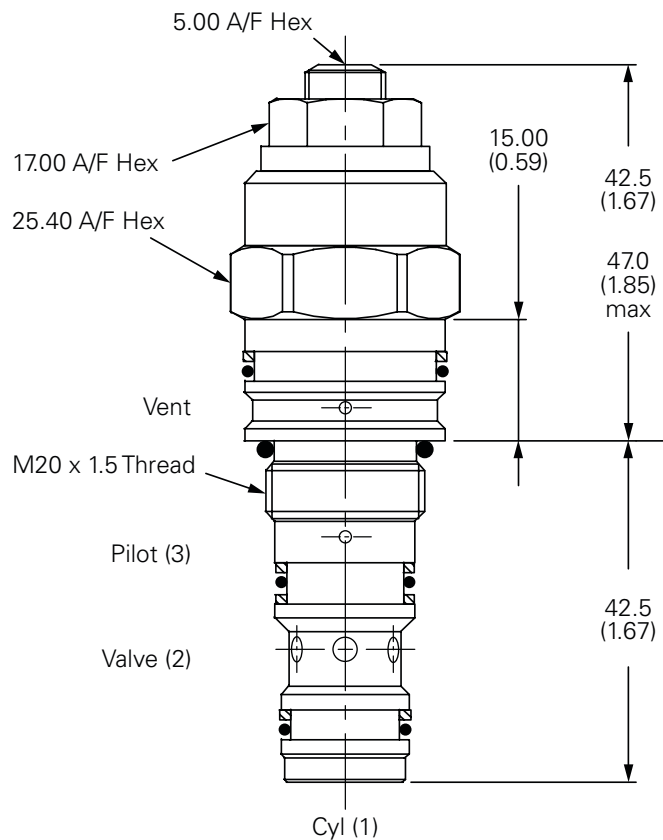

Where measurements are critical request certified drawings. We reserve the right to change specifications without notice.



# 1CEL30 - Overcenter Valve

Counterbalance pilot assisted relief with check  
 30 L/min (8 USgpm) • 380 bar (5510 psi)

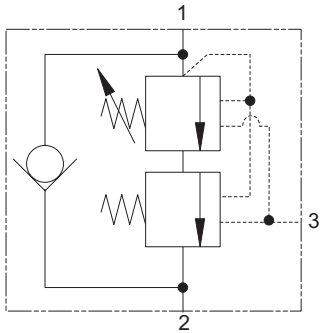

## Operation

The check section allows free flow and then locks the load against movement. The pilot assisted relief valve section will give controlled movement when pilot pressure is applied, maintaining a counterbalance pressure to prevent initial

pressure loss and therefore instability. The total pressure setting will normally be set at 1.3 times the load induced pressure. The counterbalance pressure reduces as the pilot pressure increases.

## Features

Cartridge is economical and fits simple cavity. Allows quick, easy field service - reduces down time. Interchangeable with pilot check valve of a similar size.

## Pilot Ratio

Primary 4.3:1

Secondary 0.4:1

## Sectional View

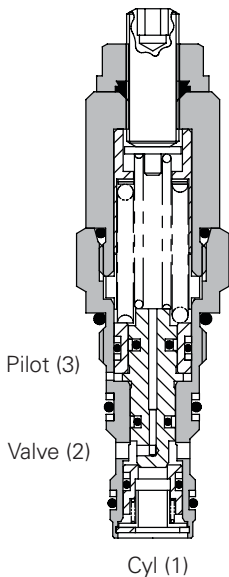

## Performance Data

### Ratings and Specifications

Performance data is typical with fluid at 32 cST (150 SUS)

Rated flow	30 L/min (8 USgpm)
Max setting	380 bar (5510 psi)
Internal leakage	0.3 ml/min (5 dpm)
Temperature range	-30° to +90°C (-22° to +194°F)
Cavity	A6610 (see Section M)
Torque cartridge into cavity	45 Nm (33 lbs ft)
Mounting position	Unrestricted
Filtration	BS5540/4 Class 18/13 (25 micron nominal)
Nominal viscosity range	5 to 500 cSt
Cartridge material	Working parts hardened and ground steel. External surfaces zinc plated.
Standard housing materials	Aluminium up to 210 bar. Add suffix "377" for steel option.
Weight	0.15 kg (0.33 lbs)
Seal kit	SK395 (Nitrile) SK395V (Viton®)

Viton is a registered trademark of E.I. DuPont

## Description

The 1CEL overcenter valve performs all duties of a regular overcenter but maintains a counterbalance pressure to provide dampening of cylinders when there is a rapid loss in stored pressure. This counterbalance pressure reduces as the pilot pressure increases. Typical applications include extension cylinders on telescopic handlers where it is important to have a smooth operation when retracting from full extension.

## Pressure Drop

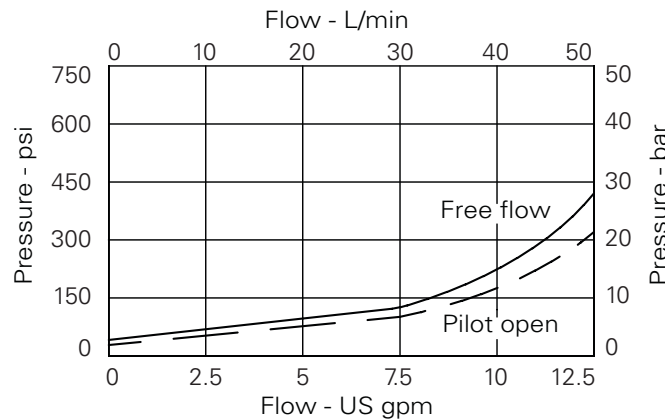

**Note:** This valve has been designed to eliminate instability from flexible boom applications or where the load induced pressure varies greatly. To get the best results, the settings should be adjusted for each application and then factory set for production quantities. Please contact our Technical Department for more information.

Where measurements are critical request certified drawings. We reserve the right to change specifications without notice.

# ICEL30 - Overcenter Valve

Counterbalance pilot assisted relief with check  
30 L/min (8 USgpm) • 380 bar (5510 psi)

Model Code

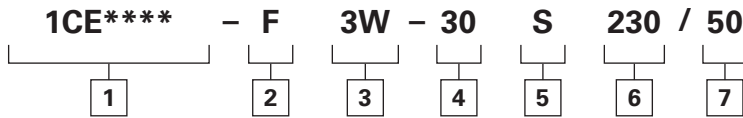

## 1 Function

**1CEL30** - Cartridge only  
**1CEL35** - Cartridge and body  
**1CEEL34** - Cartridges and dual body

## 2 Adjustment Means/Counterbalance Setting

F - Screw adjustment

For fixed versions add setting in 10 bar increments to end of part number. Subject to a ±10% tolerance.

## 3 Port Size

Code	Port Size	Housing Number - Body Only			
		Aluminium Single	Steel Single	Aluminium Dual	Steel Dual
3W	3/8" BSP valve & cylinder port. 1/4" BSP pilot port	B6743	B12823	B6836	B13803
6T	3/8" SAE valve & cylinder port. 1/4" SAE pilot port	B10536		B10805	
8T	1/2" SAE valve & cylinder port. 1/4" SAE pilot port	B7884	B11811	B30237	B11812

## 4 Pressure Range Bar @ 4.8 L/min

**Note:** Code based on pressure in bar.

**20** - 170-300 bar.  
Std setting 220 bar  
**30** - 240-370 bar.  
Std setting 280 bar  
**40** - 270-380 bar.  
Std setting 350 bar  
Std setting made at 4.8 L/min

## 5 Seals

**S** - Nitrile  
**SV** - Viton

## 6 High Pressure Setting Bar

10 bar increments  
150 to 310 bar  
(2175 to 5000 psi)

## 7 Counterbalance Setting Bar

10 bar increments  
20 to 120 bar (300 to 1740 psi)

## Dimensions

mm (inch)

### Cartridge Only

Basic Code  
1CEL30

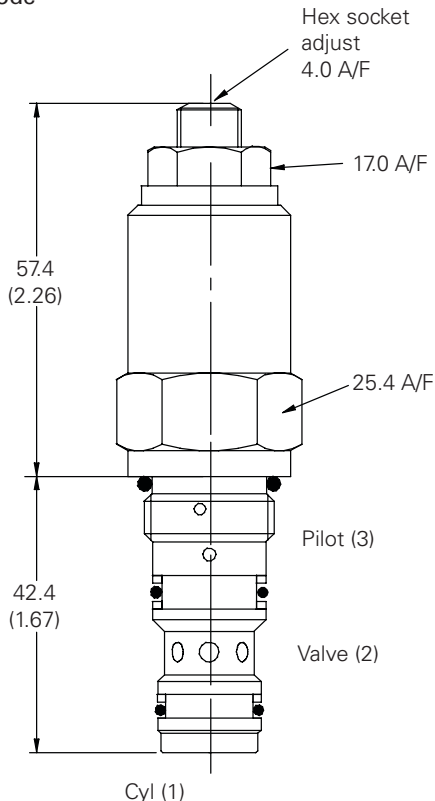

**Note:** Tightening torque of "F" adjuster locknut= 20-25 Nm.

**Note:** For applications above 210 bar - please consult our technical department or use the steel body option

### Single Valve

3/8". 1/2" Ports  
Basic Code  
1CEL35

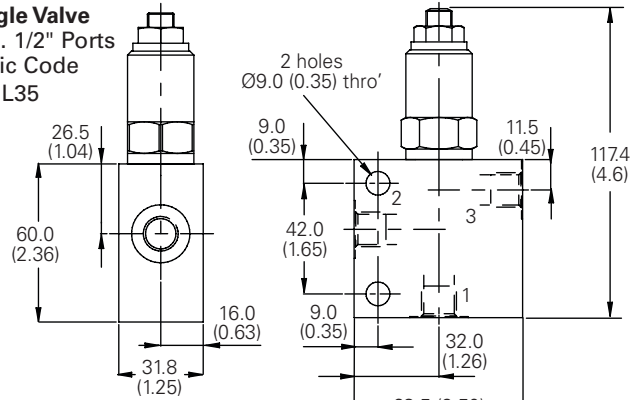

### Dual Valve

3/8". 1/2" Ports  
Basic Code 1CEEL34  
(Internally Cross Piloted)

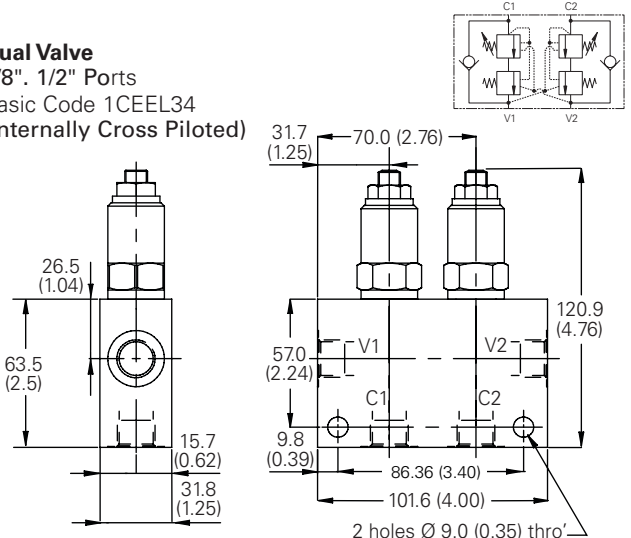

Where measurements are critical request certified drawings. We reserve the right to change specifications without notice.

# ICPBD30 - Overcenter Valve

Zero differential with check

30 L/min (8 USgpm) • 350 bar (5000 psi)

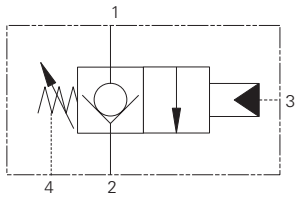

## Sectional View

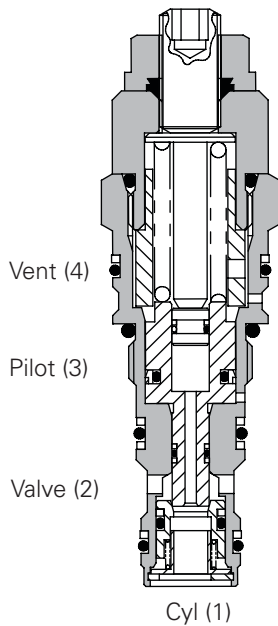

## Operation

The check section allows free flow into the actuator then holds and locks the load against movement. By the application of pilot pressure to the pilot port the poppet moves back against the main spring opening the cylinder port to the valve port. The metering characteristic of

the valve is controlled by the rate of the spring, the seat angle and the pilot pressure applied.

Due to the balanced poppet design load induced pressure will not open the valve and once open valve port pressure will not increase the pilot pressure required to keep the valve open

## Features

The cartridge fits a simple cavity allowing quick, easy field service reducing down time. Hardened poppet and seat provide for long leak free performance.

## Performance Data

### Ratings and Specifications

Figures based on: Oil Temp = 40°C Viscosity = 32 cSt (150 SUS)

Rated flow	30 L/min (8 USgpm)
Max working pressure	350 bar (5000 psi)
Cartridge material	Working parts hardened and ground steel. External surfaces zinc plated.
Mounting position	Unrestricted
Cavity	AXP20530 (See Section M)
Torque cartridge into cavity	45 Nm (33 lbs ft)
Weight	0.15 kg (0.33 lbs)
Seal kit	SK1159 (Nitrile) SK1159V (Viton®) SK1159P (Polyurethane/Nitrile)
Filtration	BS5540/4 Class 18/13 (25 micron nominal)
Temperature range	-30° to +90°C (-22° to +194°F)
Internal leakage	0.3 milliliters/min max (5 dpm)
Nominal viscosity range	5 to 500 cSt

Viton is a registered trademark of E.I. DuPont

## Description

Zero differential overcenter valves give static and dynamic control of loads by supplying a restriction to flow related to the opening of the valve created by the pilot pressure.

The valve is used in conjunction with a remote pilot source to provide hose failure protection, load control and load holding functions.

If over-pressure or shock pressure protection is required then a separate relief valve should be used

The drain line allows the valve to be used in corrosive atmospheres preventing the ingress of atmospheric contaminant.

## Pressure Drop

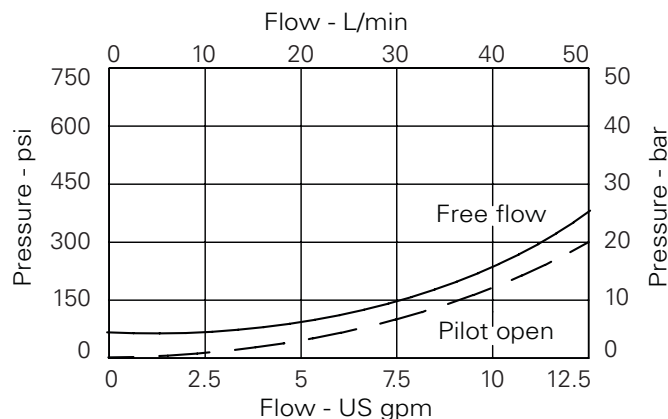

Where measurements are critical request certified drawings. We reserve the right to change specifications without notice.

# 1CPBD30 - Overcenter Valve

Zero differential with check

30 L/min (8 USgpm) • 350 bar (5000 psi)

Model Code

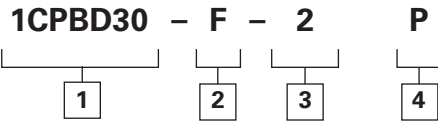

1 Function	2 Adjustment	3 Pilot Adjust Range	4 Seal Material
<b>1CPBD30</b> - Cartridge only	<b>F</b> - Screw adjustment	<b>Note:</b> Code based on pressure in bar. <b>2</b> - 5-20 bar. Std setting 10 bar Std setting made at 4.8 L/min	<b>S</b> - Nitrile (For use with most industrial hydraulic oils) <b>SV</b> - Viton (For high temperature and most special fluid applications) <b>P</b> - Polyurethane/Nitrile (For arduous applications)

## Dimensions

mm (inch)

### Cartridge Only

Basic Code 1CPBD30

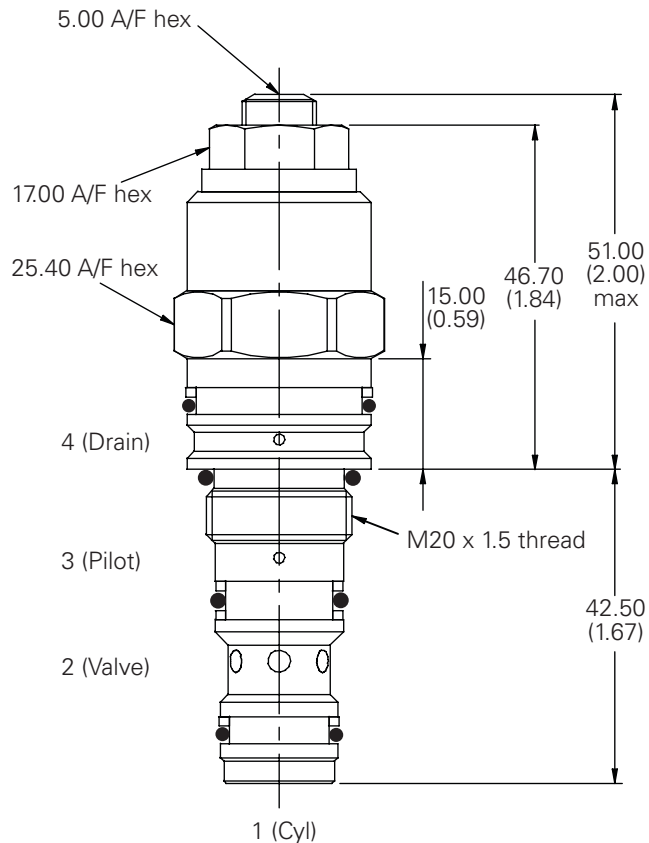

**Note:** Tightening torque of "F" adjuster locknut= 20-25 Nm.



# ICE Series - Overcenter Valve

Alternative body arrangements for 30 L/min valves

Model Code

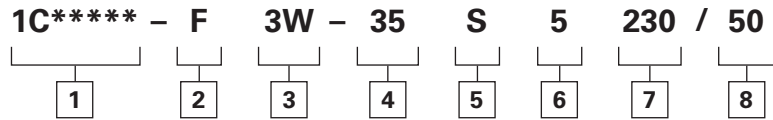

## 1 Function

- 1CE36/1CEB36/1CER36/1CEL36** - Cartridge & Body Through Ported
- 1CBE35/1CBE35/1CBER35/1CBEL35** - Cartridge & Body Banjo
- 1CEG35/1CEBG35/1CERG35/1CELG35** - Cartridge & Body Gasket
- 1CEE35/1CEEB35/1CEER35/1CEEL35** - Cartridges & Dual Body

## 4 Pressure Range @ 4.8 L/min

See cartridge data sheet

## 7 High Pressure Setting

(1CEL30 based options only)  
bar in 10 bar increments.

## 2 Adjustment Means

- F** - Screw Adjustment
- N** - Fixed - State pressure setting required

For fixed versions add setting in 10 bar increments to end of part number. Subject to a ±10% tolerance.

## 5 Seals

- S** - Nitrile (For use with most industrial hydraulic oils)
- SV** - Viton (For high temperature and most special fluid applications)

## 8 Counterbalance Setting

(1CEL30 based options only)  
bar in 10 bar increments.

## 3 Port Sizes

Code	Port Size	Housing Number	
		Aluminium	Steel
Through Ported			
<b>3W</b>	3/8" BSP - Body ONLY	B13542	B13543
Banjo Mounted			
<b>3W</b>	3/8" BSP - Sub Assembly	AXP13617-3W-S	
Gasket Mounted			
<b>3W</b>	3/8" BSP - Sub Assembly	BXP13621-3W-S	
Dual Overcenter (Internally Cross Piloted)			
<b>3W</b>	3/8" BSP - Sub Assembly	BXP24147-3W-S	BXP24147-3W-S-377
<b>6T</b>	3/4" SAE - Sub Assembly	BXP24147-6T-S	

F

# ICE Series - Overcenter Valve

Alternative body arrangements for 30 L/min valves

## Dimensions

mm (inch)

### Complete Valve - Through Ported

3/8" Ports

Basic Code

1CE36/1CEB36/1CER36/1CEL36

Banjo Bolt torque - 47 Nm

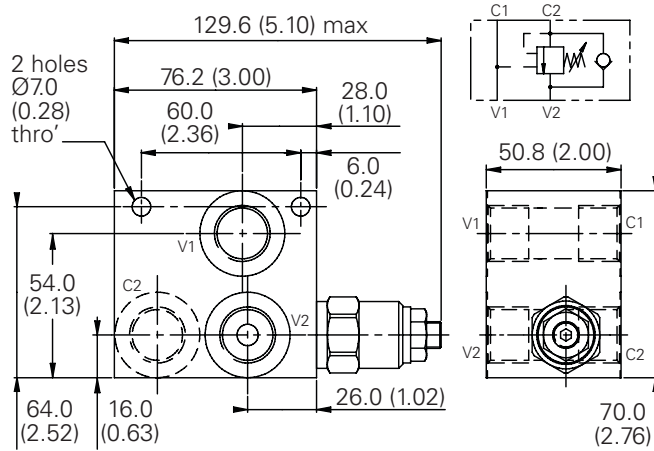

### Complete Valve - Banjo Mounted

3/8" Ports

Basic Code

1CBE35 / 1CBEB35 / 1CBER35 / 1CBEL35

Banjo Bolt torque - 47 Nm

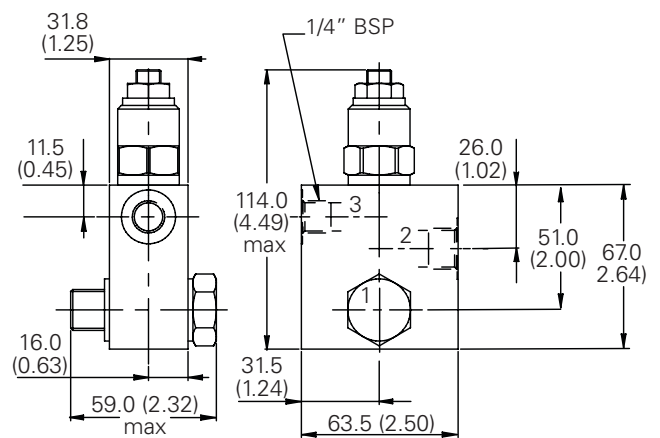

### Complete Valve - Gasket Mounted

3/8" Ports

Basic Code

1CEG35/1CEBG35/1CERG35/1CELG35

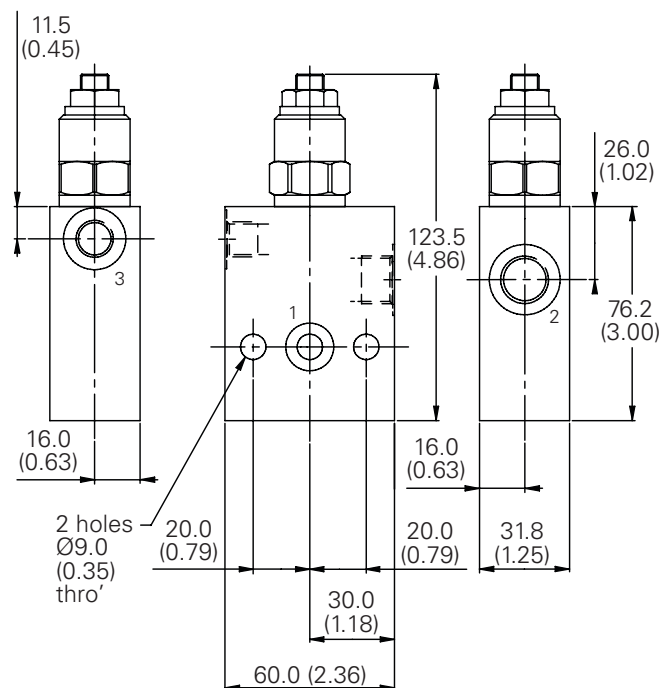

### Complete Valve - Dual Overcenter

3/8" Ports

Basic Code

1CEE35/1CEEB35/1CEER35/1CEEL35

(Internally Cross-Piloted)

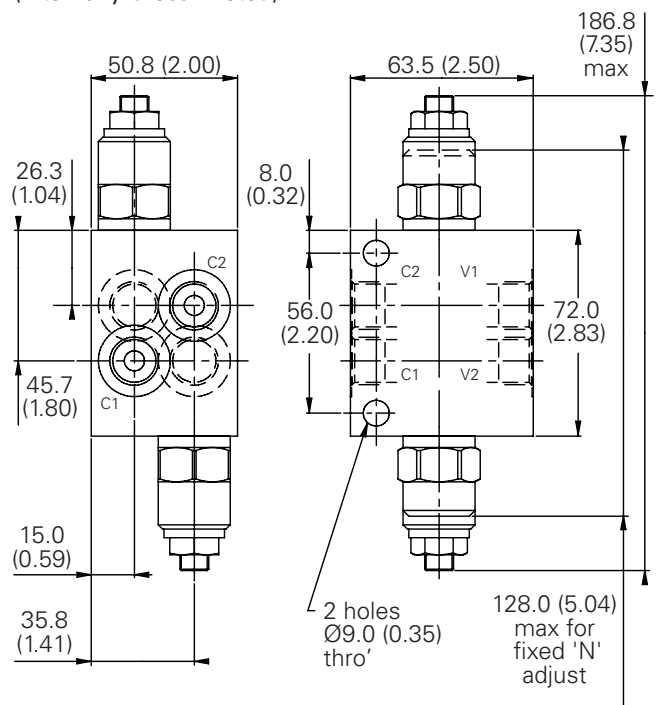

**Note:** Tightening torque of "F" adjuster locknut= 20-25 Nm.

Where measurements are critical request certified drawings. We reserve the right to change specifications without notice.

# ICE90 - Overcenter Valve

Pilot assisted relief with check

90 L/min (23 USgpm) • 270 bar (4000 psi)

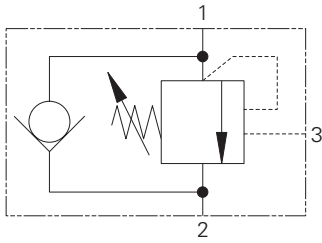

## Sectional View

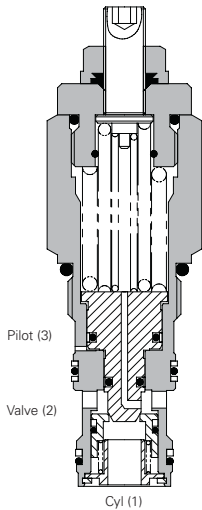

## Operation

The check section allows free flow into the actuator then holds and locks the load against movement. The pilot assisted relief valve section will give controlled movement when pilot pressure is applied. The relief section is normally set to open at a pressure at least 1.3 times the maximum load induced pressure but the

pressure required to open the valve and allow movement depends on the pilot ratio of the valve. For optimization of load control and energy usage, a choice of pilot ratios is available.

The pressure required to open the valve and start actuator movement can be calculated as follows:

$$\text{Pilot Pressure} = \frac{(\text{Relief Setting}) - (\text{Load Pressure})}{\text{Pilot Ratio}}$$

## Features

Cartridge is economical and fits simple cavity. Allows quick, easy field service - reduces down time. Interchangeable with pilot check valve of a similar size.

## Pilot Ratio

4:1 Best suited for applications where load varies and machine structure can induce instability.

8:1 Best suited for applications where the load remains relatively constant.

## Performance Data

### Ratings and Specifications

Figures based on: Oil Temp = 40°C Viscosity = 32 cSt (150 SUS)

Rated flow	90 L/min (23 USgpm)
Max relief setting	350 bar (5000 psi).
Max load Induced pressure	270 bar (4000 psi).
Cartridge material	Working parts hardened and ground steel. External surfaces zinc plated.
Standard housing materials	Aluminum (up to 210 bar). Add suffix "377" for steel option.
Mounting position	Unrestricted
Cavity number	A12336 (See Section M)
Torque cartridge into cavity	60 Nm (44 lbs ft)
Weight	1CE90 0.29 kg (0.63 lbs) 1CE95 1.35 kg (2.97 lbs) 1CEE95 2.10 kg (4.62 lbs)
Seal kit number	SK633 (Nitrile) SK633V (Viton®)
Recommended filtration level	BS5540/4 Class 18/13 (25 micron nominal)
Operating temperature	-30° to +90°C (-22° to +194°F)
Leakage	0.3 milliliters/min nominal (5 dpm)
Nominal viscosity range	5 to 500 cSt

Viton is a registered trademark of E.I. DuPont

## Description

Overcenter valves give static and dynamic control of loads by regulating the flow into and out of hydraulic actuators. When installed close to or within an actuator, the overcenter valve will stop runaway in the event of hose burst and if open center directional control valves are used, will allow thermal expansion relief of the hydraulic fluid.

The overcenter cartridge is ideal for mounting directly into a cavity machined in the body of the cylinder, motor or rotary actuator. The cartridge can also be mounted directly to the ports via a specifically machined body as part of a Hydraulic Integrated Circuit or single unit, or contained within one of our standard line bodies.

Single overcenter valves are normally used when the load is unidirectional, for example an aerial platform or crane and dual overcenter valves are used for controlling loads in both directional for motor applications or for cylinders going over center.

## Pressure Drop

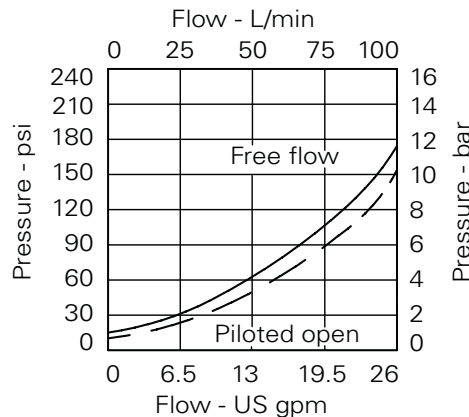

4:1 Version

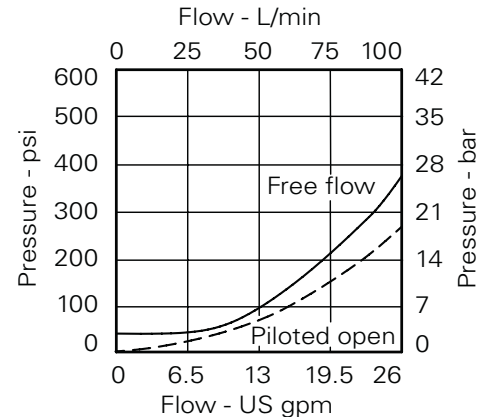

8:1 Version

Where measurements are critical request certified drawings. We reserve the right to change specifications without notice.

# ICE90 - Overcenter Valve

Pilot assisted relief with check

90 L/min (23 USgpm) • 270 bar (4000 psi)

## Model Code

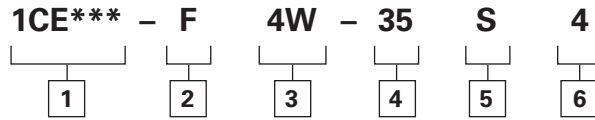

### 1 Function

- 1CE90** - Cartridge Only
- 1CE95** - Cartridge and Body
- 1CEE95** - Cartridges and Dual Body

### 2 Adjustment Means

- F** - Screw Adjustment
- N** - Fixed - State pressure setting required.

For fixed versions add setting in 10 bar increments to end of part number. Subject to a ±10% tolerance.

### 3 Port Sizes

Code	Port Size	Housing Number - Body Only			
		Aluminum Single	Steel Single	Aluminum Dual	Steel Dual
<b>Body Only</b>					
4W	1/2" BSP Valve & Cyl Port 1/4" BSP Pilot Port	B13625	B13626	C13627	C13628
8T	1/2" SAE Valve & Cyl Port 1/4" SAE Pilot Port	B10806	B10922	C10807	C11561

### 4 Pressure Range @ 4.8 l/min

**Note:** Code based on pressure in bar.

- 20** - 70-225 bar.  
Std setting 100 bar
  - 35** - 200-350 bar.  
Std setting 210 bar
- Std setting made at 4.8 L/min

### 5 Seals

- S** - Nitrile (For use with most industrial hydraulic oils)
- SV** - Viton (For high temperature and most special fluid applications)

### 6 Pilot Ratio

- 4** - 4:1
  - 8** - 8:1
- Other ratios available upon request

## Dimensions

mm (inch)

### Cartridge Only

Basic Code  
1CE90

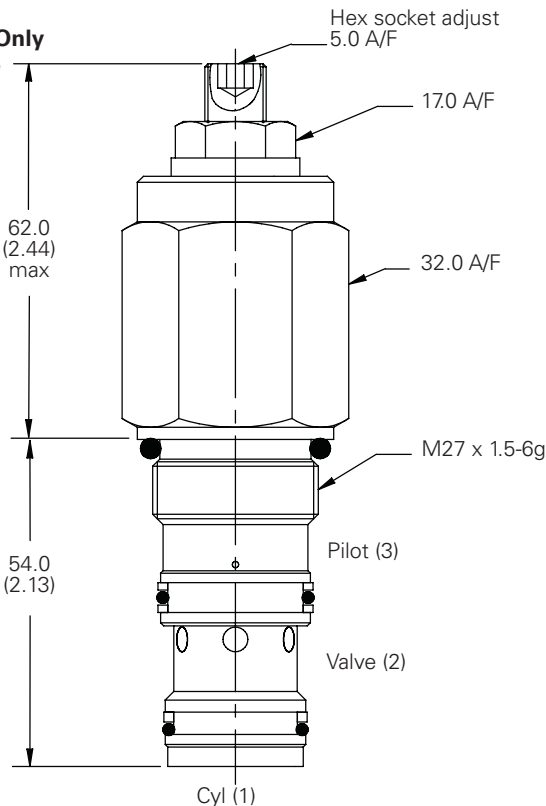

**Note:** For applications above 210 bar - please consult our technical department or use the steel body option

**Note:** Tightening torque of "F" adjuster locknut - 20 to 25 Nm

### Single Valve

1/2" Ports

Basic Code  
1CE95

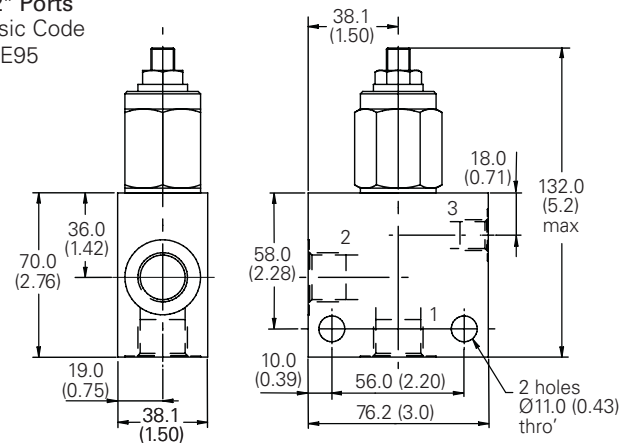

### Dual Valve

1/2" Ports

Basic Code 1CEE95  
Internally Cross Piloted

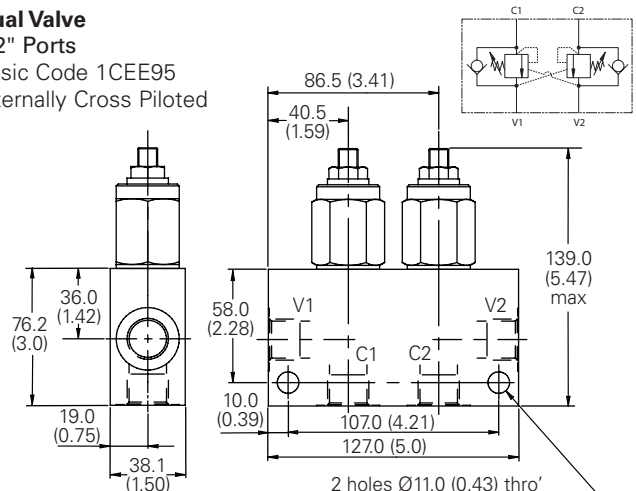

Where measurements are critical request certified drawings. We reserve the right to change specifications without notice.

# ICEH90 - High Pressure Overcenter Valve

Pilot assisted relief with check

90 L/min (23 USgpm) • 350 bar (5000 psi)

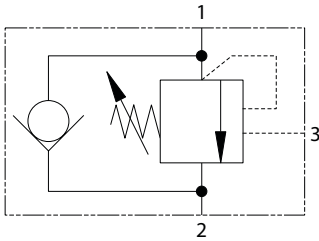

## Sectional View

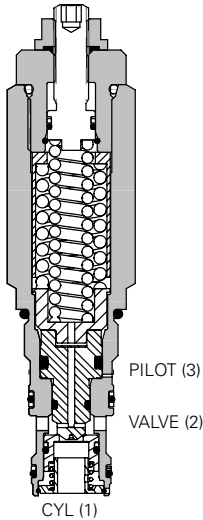

## Operation

The check section allows free flow into the actuator then holds and locks the load against movement. The pilot assisted relief valve section will give controlled movement when pilot pressure is applied. The relief section is normally set to open at a pressure at least 1.3 times the maximum load induced pressure but the

pressure required to open the valve and allow movement depends on the pilot ratio of the valve. For optimization of load control and energy usage, a choice of pilot ratios is available.

The pressure required to open the valve and start actuator movement can be calculated as follows:

$$\text{Pilot Pressure} = \frac{(\text{Relief Setting}) - (\text{Load Pressure})}{\text{Pilot Ratio}}$$

## Features

Cartridge is economical and fits simple cavity. Allows quick, easy field service - reduces down time. Interchangeable with pilot check valve of a similar size.

Dynamic seals on the internal moving parts to provide longer fatigue life.

## Pilot Ratio

4:1 Best suited for applications where load varies and machine structure can induce instability.

## Performance Data

### Ratings and Specifications

Figures based on: Oil Temp = 40°C Viscosity = 32 cSt (150 SUS)

Rated flow	90 L/min (23 USgpm)
Max relief setting	430 bar (6240 psi).
Max load induced pressure	350 bar (5000 psi).
Cartridge material	Working parts hardened and ground steel. External surfaces zinc plated.
Standard housing materials	Steel. Add suffix "377" for steel option.
Mounting position	Unrestricted
Cavity number	A12336 (See Section M)
Torque cartridge into cavity	100-110 Nm (73-81 lbs ft)
Weight	1CEH90 0.6 kg (1.32 lbs) 1CEH95 1.66 kg (3.66 lbs) 1CEEH95 2.72 kg (6.00 lbs)
Seal kit number	9900927-000 (Nitrile) 9900928-000 (Viton®)
Recommended filtration level	BS5540/4 Class 18/13 (25 micron nominal)
Operating temperature	-30° to +90°C (-22° to +194°F)
Leakage	5 dpm @ 85% of Cracking
Nominal viscosity range	5 to 500 cSt

Viton is a registered trademark of E.I. DuPont

## Pressure Drop

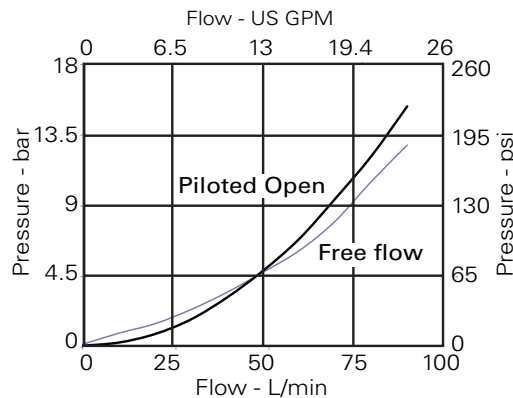

4:1 Version

## Description

Overcenter valves give static and dynamic control of loads by regulating the flow into and out of hydraulic actuators. When installed close to or within an actuator, the overcenter valve will stop runaway in the event of hose burst and if open center directional control valves are used, will allow thermal expansion relief of the hydraulic fluid.

The overcenter cartridge is ideal for mounting directly into a cavity machined in the body of the cylinder, motor or rotary actuator. The cartridge can also be mounted directly to the ports via a specifically machined body as part of a Hydraulic Integrated Circuit or single unit, or contained within one of our standard line bodies.

Single overcenter valves are normally used when the load is unidirectional, for example an aerial platform or crane and dual overcenter valves are used for controlling loads in both directional for motor applications or for cylinders going over center.

Where measurements are critical request certified drawings. We reserve the right to change specifications without notice.

# ICEH90 - High Pressure Overcenter Valve

Pilot assisted relief with check

90 L/min (23 USgpm) • 350 bar (5000 psi)

## Model Code

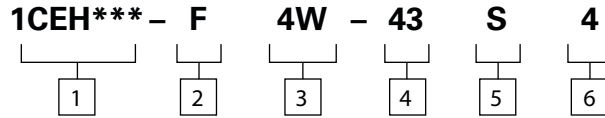

### 1 Function

**1CEH90** - Cartridge Only  
**1CEH95** - Cartridge and Body  
**1CEEH95** - Cartridges and Dual Body

### 2 Adjustment Means

**F** - Screw Adjustment

### 3 Port Sizes

Code	Port Size	Housing Number - Body Only	
		Steel Single	Steel Dual
4W	1/2" BSP Valve & Cyl Port 1/4" BSP Pilot Port	B13626	C13628
8T	1/2" SAE Valve & Cyl Port 1/4" SAE Pilot Port	B10922	C11561

### 4 Pressure Range

**Note:** Code based on pressure in bar.

**43** - (4:1) 275 - 430 bar.  
 Std setting 350 bar

Std setting made at 1 L/min

**Note:** Contact CSR for special pressure setting requirement

### 5 Seals

**S** - Nitrile (For use with most industrial hydraulic oils)

**SV** - Viton (For high temperature and most special fluid applications)

### 6 Pilot Ratio

**4** - 4:1

Other ratios available upon request

## Dimensions mm (inch)

### Cartridge Only

Basic Code  
 1CEH90

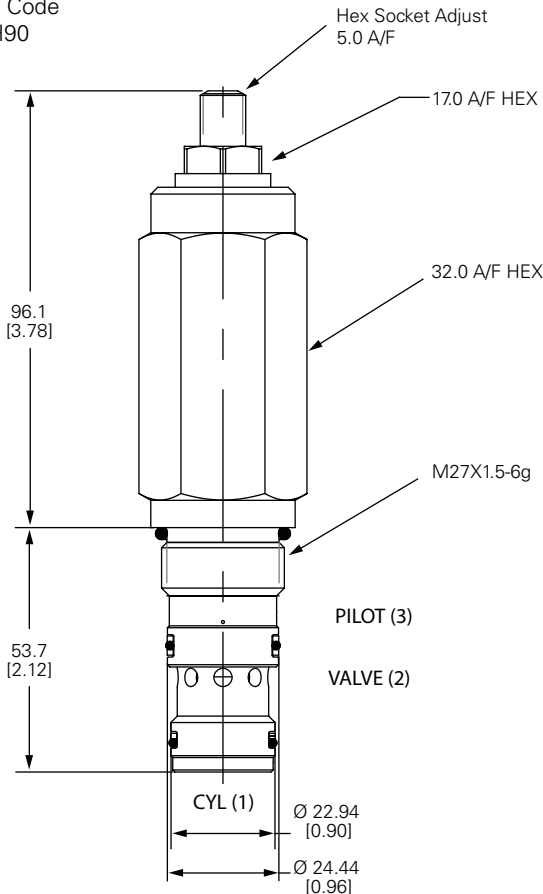

**Note:** Tightening torque of "F" adjuster locknut - 20 to 25 Nm

### Single Valve

1/2" Ports  
 Basic Code  
 1CEH95

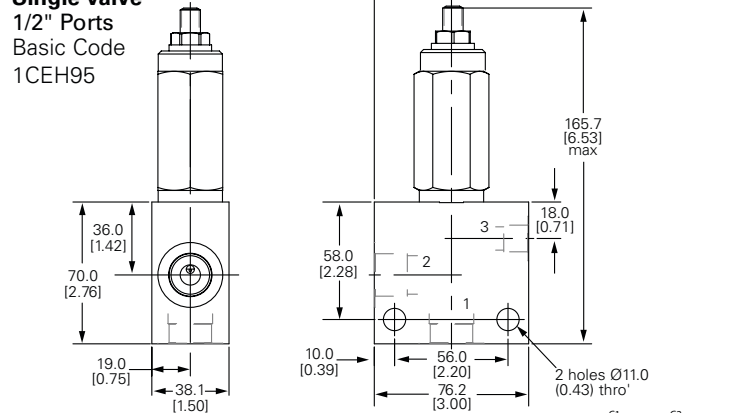

**Dual Valve**  
 1/2" Ports  
 Basic Code 1CEEH95  
 Internally Cross Piloted

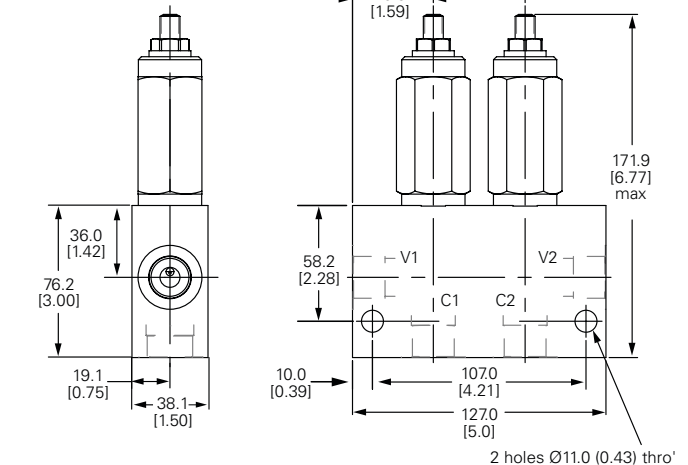

Where measurements are critical request certified drawings. We reserve the right to change specifications without notice.

# 1CER90 - Overcenter Valve

Part balanced, pilot assisted relief with check  
90 L/min (23 USgpm) • 270 bar (4000 psi)

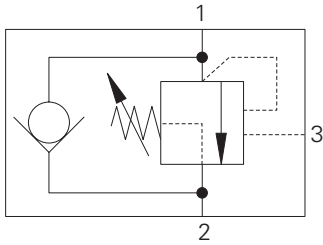

## Sectional View

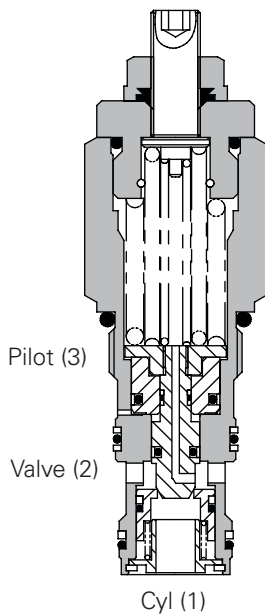

## Operation

The check section allows free flow into the actuator then holds and locks the load against movement. The pilot assisted relief valve section will give controlled movement when pilot pressure is applied. The relief section is normally set to open at a pressure at least 1.3 times the maximum load induced pressure but the pressure required to open the valve and allow movement

depends on the pilot ratio of the valve. For optimization of load control and energy usage, a choice of pilot ratios is available.

The pressure required to open the valve and start actuator movement can be calculated as follows:

$$\text{Pilot Pressure} = \frac{(\text{Relief Setting}) - (\text{Load Pressure})}{\text{Pilot Ratio}}$$

## Features

Cartridge is economical and fits simple cavity. Allows quick, easy field service - reduces down time. Interchangeable with pilot check valve of a similar size.

## Pilot Ratio

4:1 Best suited for applications where load varies and machine structure can induce instability.

Other ratios available upon request.

## Performance Data

### Ratings and Specifications

Figures based on: Oil Temp = 40°C Viscosity = 32 cSt (150 SUS)

Rated flow	90 L/min (23 USgpm)
Max relief pressure	350 bar (5000 psi)
Max load induced pressure	270 bar (4000 psi)
Cartridge material	Working parts hardened and ground steel. External surfaces zinc plated.
Standard housing materials	Aluminum up to 210 bar. Add suffix "377" for steel option.
Cavity	A12336 (see Section M)
Mounting position	Unrestricted
Torque cartridge into cavity	60 Nm (44 lbs ft)
Weight	1CER90 29 kg (.63 lbs) 1CER95 1.35 kg (2.97 lbs) 1CEER95 2.10 kg (4.62 lbs)
Seal kit	SK633 (Nitrile) SK633V (Viton®)
Filtration	BS5540/4 Class 18/13 (25 micron nominal)
Temperature range	-30° to +90°C (-22° to +194°F)
Internal leakage	0.3 ml/min (5 dpm)
Nominal viscosity range	5 to 500 cSt

Viton is a registered trademark of E.I. DuPont

## Description

The 1CER series overcenter valve performs all duties of a regular overcenter but is able to relieve and stay open irrespective of downstream pressure. This enables the valve to operate when used with a closed center directional valve which has service line reliefs. The poppet is pressure balanced, preventing relief setting increase due to back pressure.

## Pressure Drop

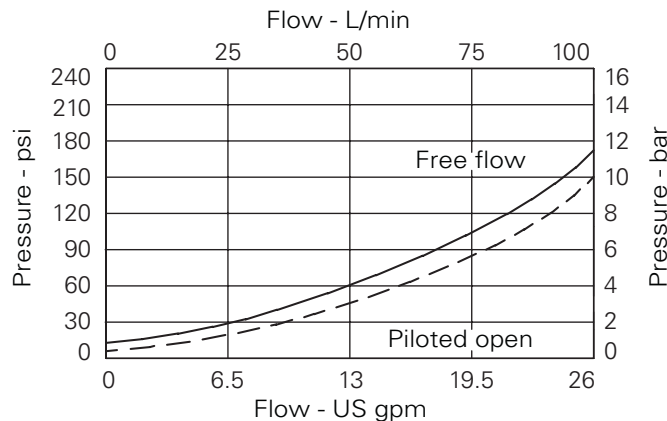

Where measurements are critical request certified drawings. We reserve the right to change specifications without notice.

# ICER90 - Overcenter Valve

Part balanced, pilot assisted relief with check  
90 L/min (23 USgpm) • 270 bar (4000 psi)

## Model Code

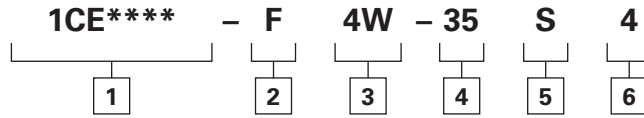

### 1 Function

**1CER90** - Cartridge only  
**1CER95** - Cartridge and body  
**1CEER95** - Cartridges and body

### 2 Adjustment

**F** - Screw adjustment  
**N** - Fixed - State pressure setting required.

For fixed versions add setting in 10 bar increments to end of part number. Subject to a +/-10% tolerance.

### 3 Port Size

**Code**    **Port Size**

4W    1/2" BSP Valve & Cyl Port 1/4" BSP Pilot Port  
8T    1/2" SAE Valve & Cyl Port 1/4" SAE Pilot Port

**Housing Number - Body Only**

Aluminum Single	Steel Single	Aluminum Dual	Steel Dual
-----------------	--------------	---------------	------------

B13625	B13626	C13627	C13628
B10806	B10922	C10807	C11561

### 4 Pressure Range @ 4.8 L/min

**Note:** Code based on pressure in bar.

**20** - 70-225 bar.  
Std setting 100 bar  
**35** - 200-350 bar.  
Std setting 210 bar  
Std setting made at 4.8 L/min

### 5 Seal Material

**S** - Nitrile (For use with most industrial hydraulic oils)  
**SV** - Viton (For high temperature and most special fluid applications)

### 6 Pilot Ratio

**4 - 4:1** Other ratios available upon request

## Dimensions

mm (inch)

### Cartridge Only

Basic Code

1CER90

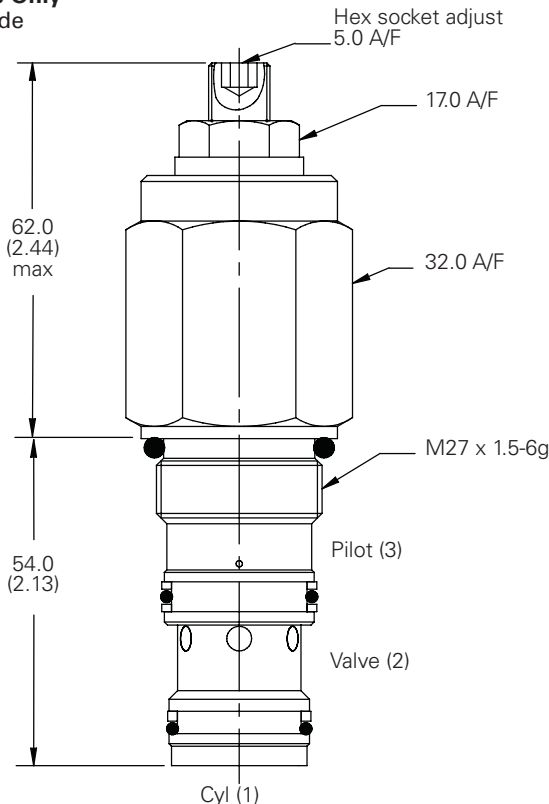

**Note:** For applications above 210 bar - please consult our technical department or use the steel body option.

**Note:** Tightening torque of "F" adjuster locknut - 20 to 25 Nm.

### Single Valve 1/2" Ports Basic Code 1CER95

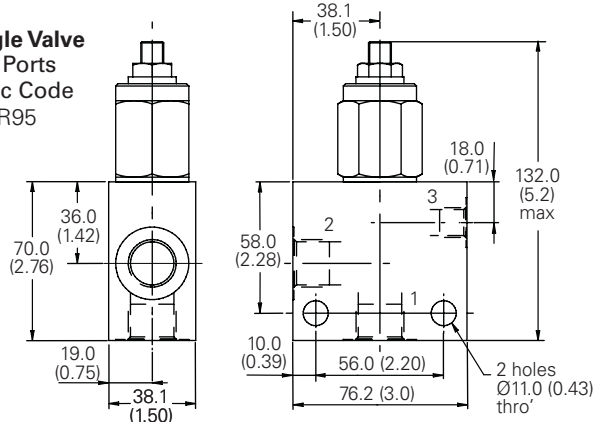

### Dual Valve 1/2" Ports Basic Code 1CEER95 Internally Cross Piloted

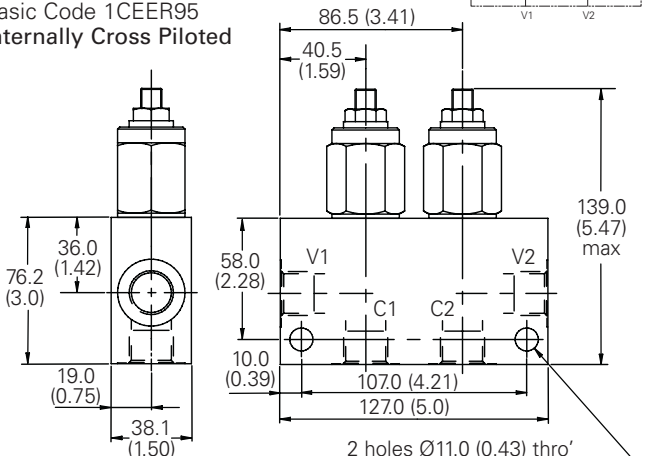

Where measurements are critical request certified drawings. We reserve the right to change specifications without notice.

# 1CERH90 - High Pressure Overcenter Valve

Part balanced, pilot assisted relief with check

90 L/min (23 USgpm) • 350 bar (5000 psi)

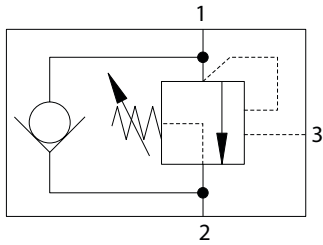

## Sectional View

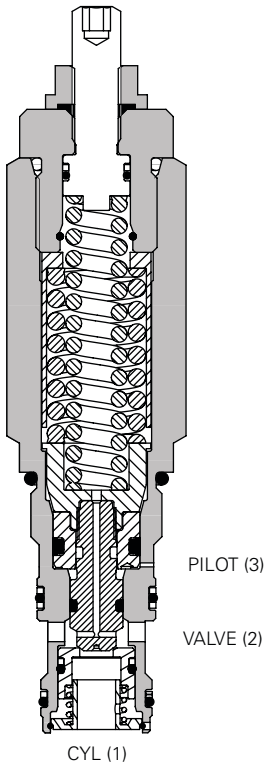

## Operation

The check section allows free flow into the actuator then holds and locks the load against movement. The pilot assisted relief valve section will give controlled movement when pilot pressure is applied. The relief section is normally set to open at a pressure at least 1.3 times the maximum load induced pressure but the pressure required to open the valve and allow movement

depends on the pilot ratio of the valve. For optimization of load control and energy usage, a choice of pilot ratios is available.

The pressure required to open the valve and start actuator movement can be calculated as follows:

$$\text{Pilot Pressure} = \frac{(\text{Relief Setting}) - (\text{Load Pressure})}{\text{Pilot Ratio}}$$

## Features

Cartridge is economical and fits simple cavity. Allows quick, easy field service - reduces down time. Interchangeable with pilot check valve of a similar size.

Dynamic seals on the internal moving parts to provide longer fatigue life.

## Pilot Ratio

4:1 Best suited for applications where load varies and machine structure can induce instability.

Other ratios available upon request.

## Performance Data

### Ratings and Specifications

Figures based on: Oil Temp = 40°C Viscosity = 32 cSt (150 SUS)

Rated flow	90 L/min (23 USgpm)
Max relief pressure	430 bar (6240 psi)
Max load induced pressure	350 bar (5000 psi)
Cartridge material	Working parts hardened and ground steel. External surfaces zinc plated.
Standard housing materials	Steel. Add suffix "377"
Cavity	A12336 (see Section M)
Mounting position	Unrestricted
Torque cartridge into cavity	100-110 Nm (73-81 lbs ft)
Weight	1CERH90 0.6 kg (1.32 lbs) 1CERH95 1.66 kg (3.66 lbs) 1CEERH95 2.72 kg (6.00 lbs)
Seal kit	9900927-000 (Nitrile) 9900928-000 (Viton®)
Filtration	BS5540/4 Class 18/13 (25 micron nominal)
Temperature range	-30° to +90°C (-22° to +194°F)
Internal leakage	5 dpm @ 85% of Cracking
Nominal viscosity range	5 to 500 cSt

Viton is a registered trademark of E.I. DuPont

## Description

The 1CERH series overcenter valve performs all duties of a regular overcenter but is able to relieve and stay open irrespective of downstream pressure. This enables the valve to operate when used with a closed center directional valve which has service line reliefs. The poppet is pressure balanced, preventing relief setting increase due to back pressure.

## Pressure Drop

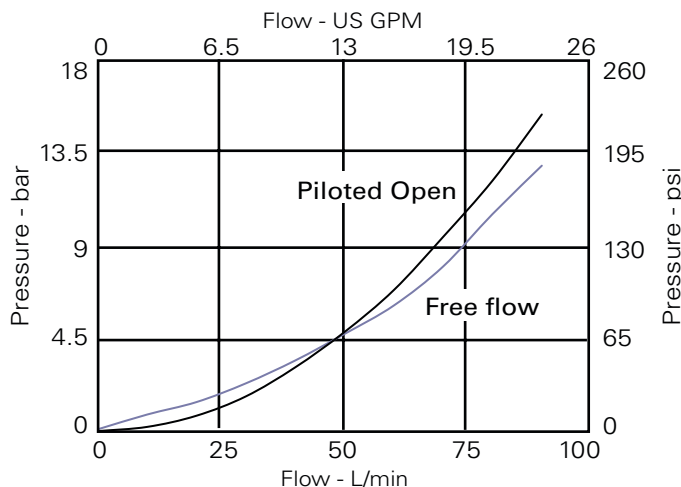

Where measurements are critical request certified drawings. We reserve the right to change specifications without notice.

# 1CERH90 - High Pressure Overcenter Valve

Part balanced, pilot assisted relief with check  
 90 L/min (23 USgpm) • 350 bar (5000 psi)

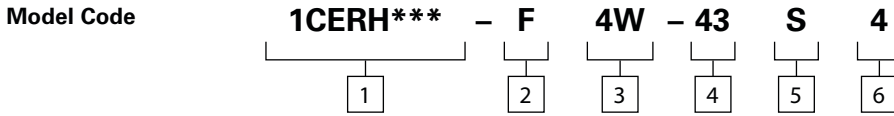

**1 Function**

**1CERH90** - Cartridge only  
**1CERH95** - Cartridge and body  
**1CEERH95** - Cartridges and body

**2 Adjustment**

F - Screw adjustment

**3 Port Size**

Code	Port Size	Housing Number - Body Only	
		Steel Single	Steel Dual
4W	1/2" BSP Valve & Cyl Port 1/4" BSP Pilot Port	B13626	C13628
8T	1/2" SAE Valve & Cyl Port 1/4" SAE Pilot Port	B10922	C11561

**4 Pressure Range**

**Note:** Code based on pressure in bar.  
**43** - (4:1) 275-430 bar. Std setting 350 bar  
 Std setting made at 1L/min  
**Note:** Contact CSR for special pressure setting requirement

**5 Seal Material**

**S** - Nitrile (For use with most industrial hydraulic oils)  
**SV** - Viton (For high temperature and most special fluid applications)

**6 Pilot Ratio**

**4 - 4:1** Other ratios available upon request



**Dimensions**  
 mm (inch)

**Note:** Tightening torque of "F" adjuster locknut - 20 to 25 Nm

**Cartridge Only**  
 Basic Code  
 1CERH90

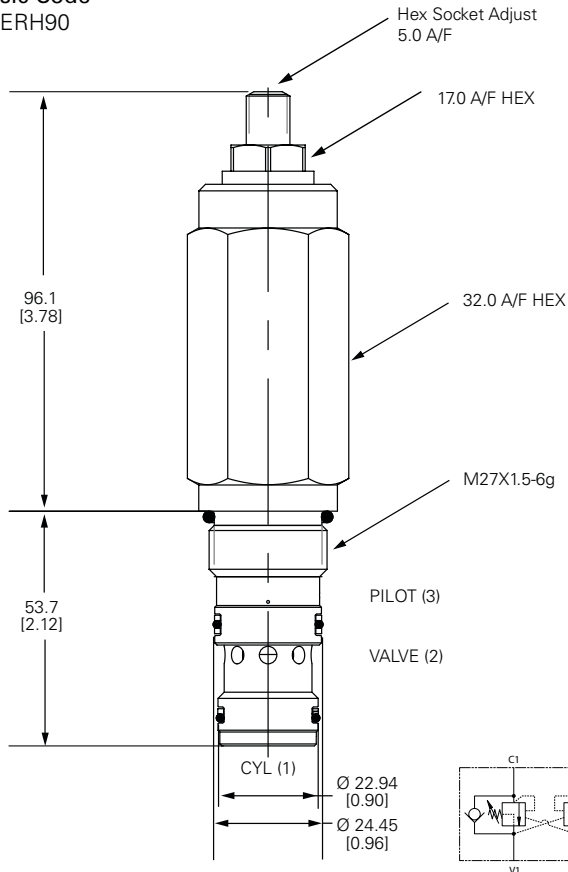

**Single Valve**  
 1/2" Ports  
 Basic Code  
 1CERH95

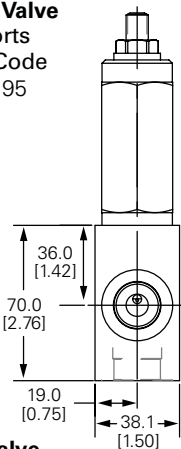

**Dual Valve**  
 1/2" Ports  
 Basic Code 1CEERH95  
 Internally  
 Cross Piloted

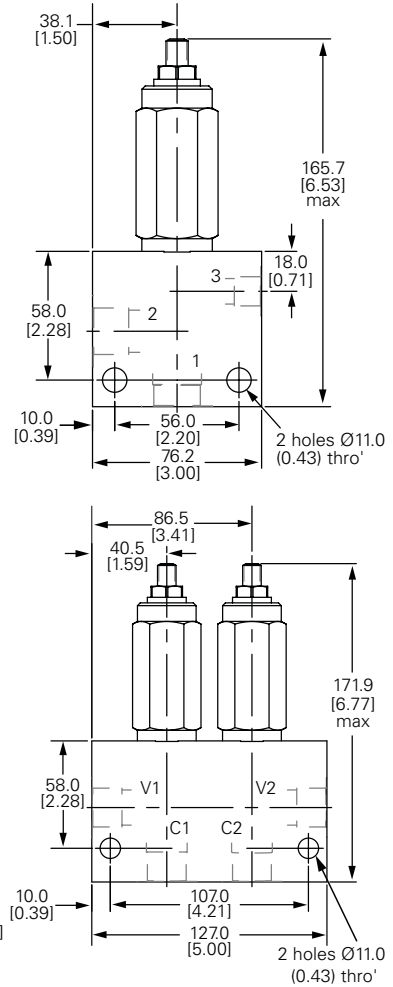
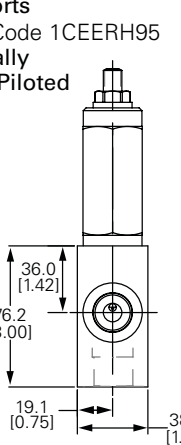

Where measurements are critical request certified drawings. We reserve the right to change specifications without notice.

# ICEB90 - Overcenter Valve

Fully balanced, pilot assisted relief with check  
90 L/min (23 USgpm) • 270 bar (4000 psi)

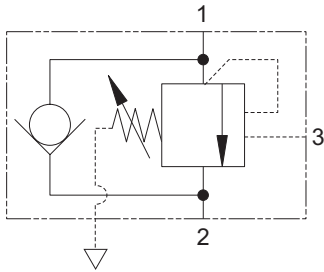

## Operation

The check section allows free flow into the actuator then holds and locks the load against movement. The pilot assisted relief valve section will give controlled movement when pilot pressure is applied. The relief section is normally set to open at a pressure at least 1.3 times the maximum load induced pressure but the pressure required to open the valve and allow movement

depends on the pilot ratio of the valve. For optimization of load control and energy usage, a choice of pilot ratios is available.

The pressure required to open the valve and start actuator movement can be calculated as follows:

$$\text{Pilot Pressure} = \frac{(\text{Relief Setting}) - (\text{Load Pressure})}{\text{Pilot Ratio}}$$

## Features

Cartridge is economical and fits simple cavity. Allows quick, easy field service - reduces down time. Interchangeable with pilot check valve of a similar size.

## Pilot Ratio

4:1 Best suited for applications where load varies and machine structure can induce instability.

Other ratios available upon request.

## Sectional View

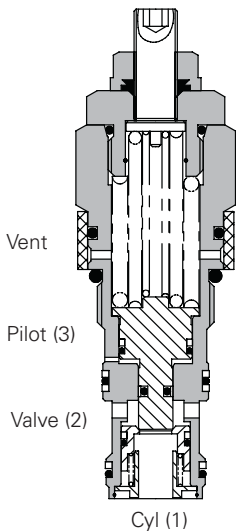

## Performance Data

### Ratings and Specifications

Performance data is typical with fluid at 32 cST (150 SUS)

Rated flow	90 L/min (23 USgpm)
Max relief pressure	350 bar (5000 psi)
Max load induced pressure	270 bar (4000 psi)
Cartridge material	Working parts steel. External surfaces zinc plated.
Standard housing materials	Aluminum up to 210 bar. Add suffix "377" for steel option.
Mounting position	Unrestricted
Cavity	A12336 (see Section M)
Torque cartridge into cavity	60 Nm (44 lbs ft)
Weight	1CEB90: .29 kg (.63 lbs) 1CEB95: 1.35 kg (2.97 lbs) 1CEE95: 2.10 kg (4.62 lbs)
Seal kit	SK634 (Nitrile) SK634V (Viton®)
Filtration	BS5540/4 Class 18/13 (25 micron nominal)
Temperature range	-30° to +90°C (-22° to +194°F)
Internal leakage	0.3 ml/min (5 dpm)
Nominal viscosity range	5 to 500 cSt

Viton is a registered trademark of E.I. DuPont

## Description

Overcenter valves give static and dynamic control of loads by supplying a counterbalance pressure to the actuator. They prevent runaway in the event of hose burst and hold the load with minimal leakage.

The pressure balanced valve is unaffected by back pressure, allowing service line reliefs to operate and for the valve to be used in regenerative or proportional valve systems.

The overcenter valve should be mounted either into, onto or as close to the actuator as possible to give maximum protection.

Single overcenter valves control unidirectional loads such as in aerial platforms, cranes or winches and dual overcenters are suited to bi-directional motion such as wheel motor applications or cylinders going over center.

## Pressure Drop

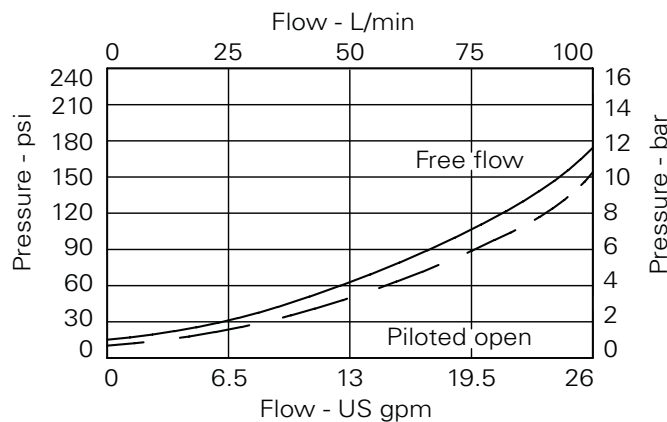

Where measurements are critical request certified drawings. We reserve the right to change specifications without notice.

# 1CEB90 - Overcenter Valve

Fully balanced, pilot assisted relief with check  
90 L/min (23 USgpm) • 270 bar (4000 psi)

## Model Code

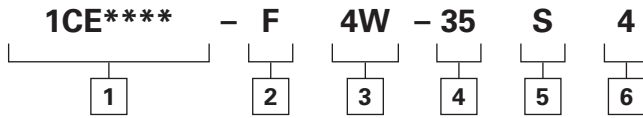

## 1 Function

**1CEB90** - Cartridge only  
**1CEB95** - Cartridge and body  
**1CEEB95** - Cartridges and dual body

## 2 Adjustment

**F** - Screw adjustment  
**N** - Fixed - State pressure setting required.

For fixed versions add setting in 10 bar increments to end of part number. Subject to a ±10% tolerance.

## 3 Port Size

Code	Port Size	Housing Number - Body Only			
		Aluminium Single	Steel Single	Aluminium Dual	Steel Dual
<b>Body Only</b>					
4W	1/2" BSP Valve & Cyl Port 1/4" BSP Pilot Port	B13625	B13626	C13627	C13628
8T	1/2" SAE Valve & Cyl Port 1/4" SAE Pilot Port	B10806	B10922	C10807	C11561

## 4 Pressure Range @ 4.8 L/min

**Note:** Code based on pressure in bar.

**20** - 70-225 bar.  
Std setting 100 bar

**35** - 200-350 bar.  
Std setting 210 bar

Std setting made at 4.8 L/min

## 5 Seal Material

**S** - Nitrile (For use with most industrial hydraulic oils)

**SV** - Viton (For high temperature and most special fluid applications)

## 6 Pilot Ratio

**4 - 4:1** Other ratios available upon request

## Dimensions

mm (inch)

### Cartridge Only

Basic Code  
1CEB90

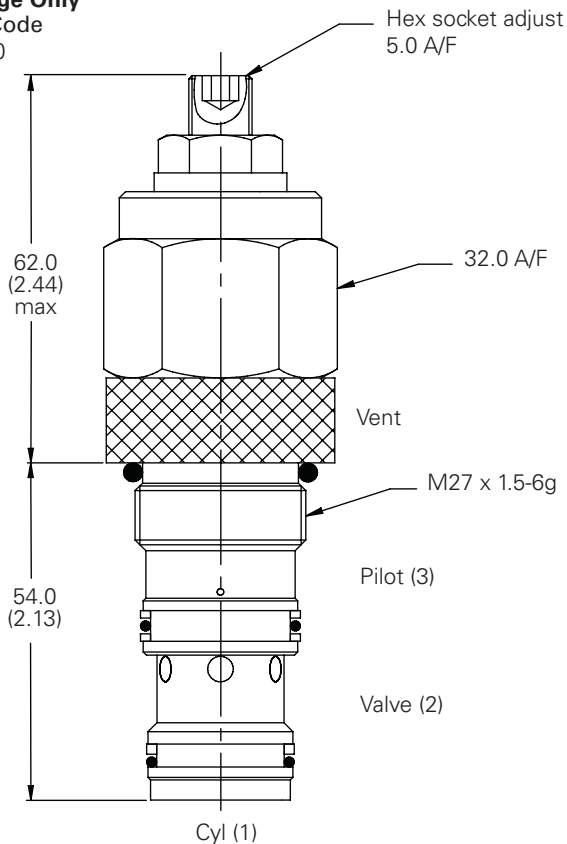

**Note:** Tightening torque of "F" adjuster locknut - 20 to 25 Nm.

**Note:** For applications above 210 bar - please consult our technical department or use the steel body option.

### Single Valve

1/2" Ports  
Basic Code  
1CEB95

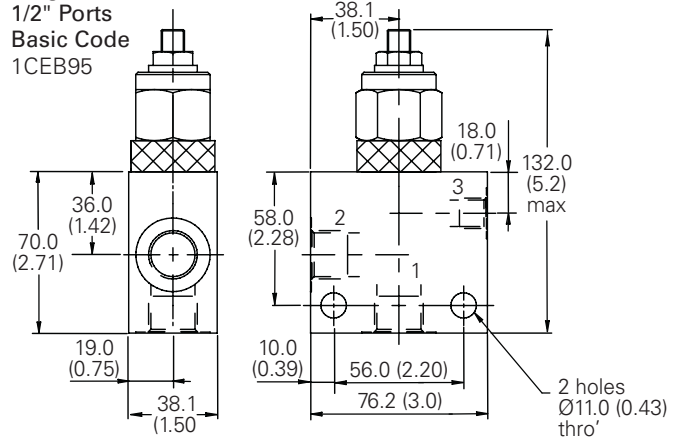

### Dual Valve

1/2" Ports  
Basic Code 1CEEB95  
Internally Cross Piloted

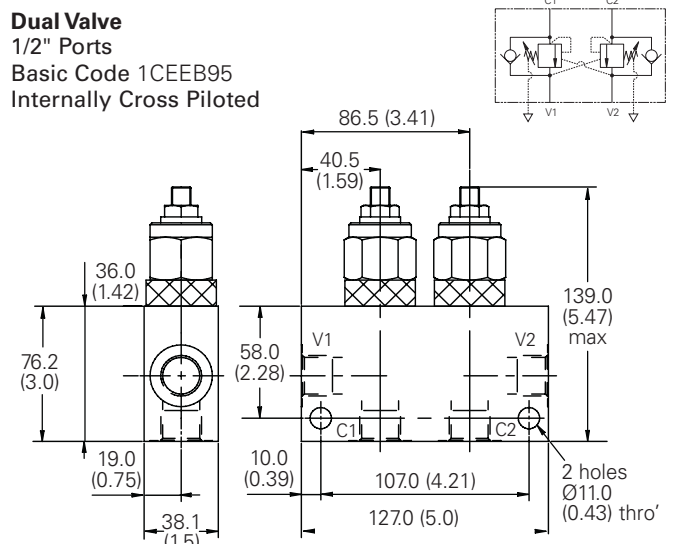

Where measurements are critical request certified drawings. We reserve the right to change specifications without notice.

# ICEBD90 - Overcenter Valve

Fully balanced, pilot assisted relief with check  
90 L/min (23 USgpm) • 270 bar (4000 psi)

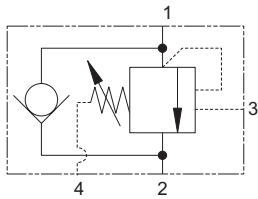

## Sectional View

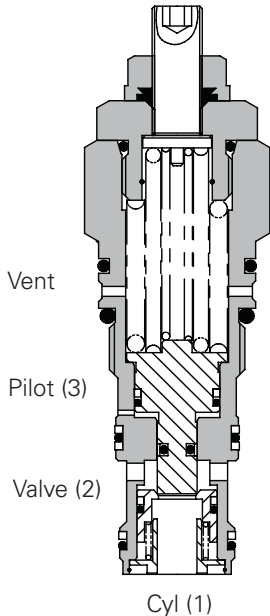

## Description

Overcenter valves give static and dynamic control of loads by supplying a counterbalance pressure to the actuator. They will stop runaway in the event of hose burst and hold the load with minimal leakage.

The pressure balanced overcenter relief setting is unaffected by back pressure, enabling the valve to stay open when the valve port pressure rises. This will allow service line reliefs to work normally and will also allow the control of regenerative or proportional systems. The drain line allows the valve to be used in corrosive atmospheres preventing the ingress of atmospheric contaminant.

Single overcenter valves are normally used when the load is unidirectional, for example an aerial platform or crane and dual overcenter valves are used for controlling loads in both directional for motor applications or for cylinders going over center.

Where measurements are critical request certified drawings. We reserve the right to change specifications without notice.

## Operation

The check section allows free flow into the actuator then holds and locks the load against movement. The pilot assisted relief valve section will give controlled movement when pilot pressure is applied. The relief section is normally set to open at a pressure at least 1.3 times the maximum load induced pressure but the pressure required to open the

valve and allow movement depends on the pilot ratio of the valve. For optimization of load control and energy usage, a choice of pilot ratios is available.

The pressure required to open the valve and start actuator movement can be calculated as follows:

$$\text{Pilot Pressure} = \frac{(\text{Relief Setting}) - (\text{Load Pressure})}{\text{Pilot Ratio}}$$

## Features

Cartridge is economical and fits simple cavity. Allows quick, easy field service - reduces down time.

## Pilot Ratio

4:1 Best suited for applications where load varies and machine structure can induce instability.

Other ratios available upon request.

## Performance Data

### Ratings and Specifications

Figures based on Oil Temp = 40°C Viscosity = 32 cSt (150 SUS)

Rated flow	90 L/min (23 USgpm)
Max relief setting	350 bar (5000 psi)
Max load induced pressure	270 bar (4000 psi)
Cartridge material	Working parts hardened and ground steel. External surfaces zinc plated.
Mounting position	Unrestricted
Cavity	A12196 (See section M)
Torque cartridge into cavity	60 Nm (44 lbs ft)
Weight	0.29 kg (0.63 lbs)
Seal kit	SK634 (Nitrile) SK634V (Viton®) SK634P (Polyurethane/Nitrile)
Filtration	BS5540/4 Class 18/13 (25 micron nominal)
Temperature range	-30° to +90°C (-22° to +194°F)
Leakage	0.3 milliliters/min (5 dpm)
Nominal viscosity range	5 to 500 cSt

Viton is a registered trademark of E.I. DuPont

## Pressure Drop

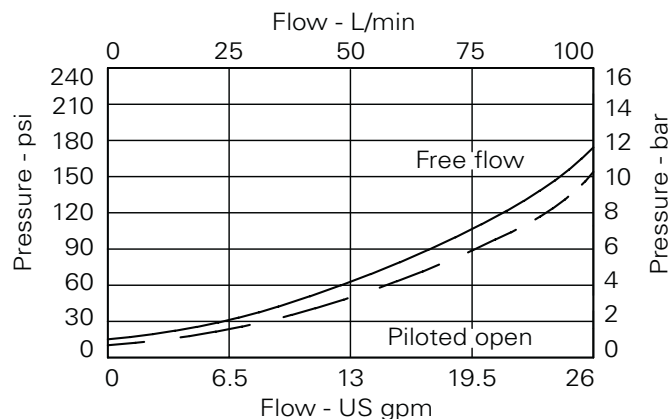

# ICEBD90 - Overcenter Valve

Fully balanced, pilot assisted relief with check  
 90 L/min (23 USgpm) • 270 bar (4000 psi)

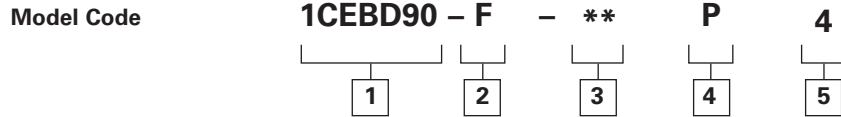

**1 Function**  
**1CEBD90**

**2 Adjustment Means**  
**F** - Screw adjustment

**3 Pressure Range @ 4.8 L/min**  
**Note:** Code based on pressure in bar.  
**20** - 70-225 bar  
           Standard setting 100 bar  
**35** - 200-350 bar  
           Standard setting 210 bar  
 Standard setting made at 4.8 L/min

**4 Seals**  
**S** - Nitrile (for use with most industrial hydraulic oils)  
**SV** - Viton (for high temperature and most special fluid applications)  
**P** - Polyurethane/Nitrile (for arduous applications)

**5 Pilot Ratio**  
**4** - 4:1  
 Other ratios available upon request

Line body available on request.

## Dimensions

mm (inch)

## Cartridge Only

Basic Code  
 1CEBD90

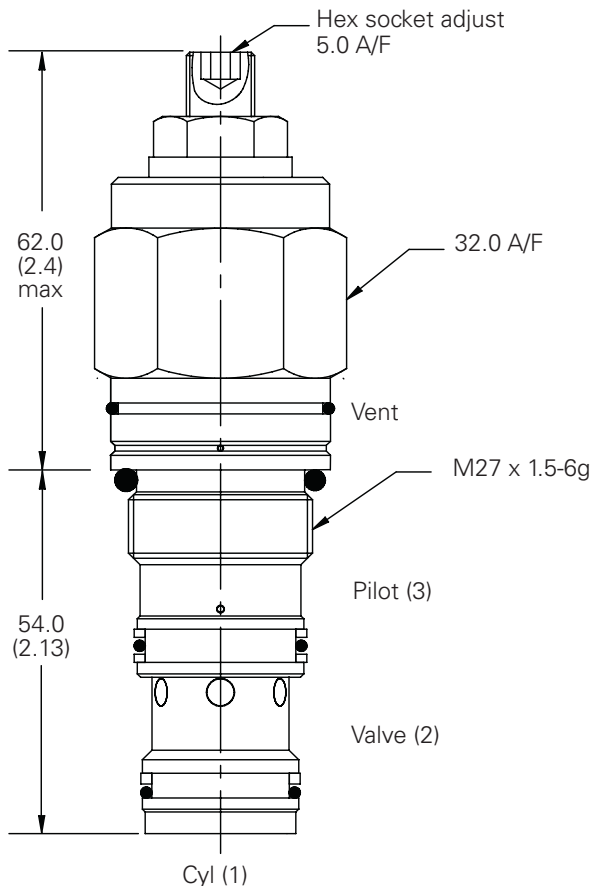

**Note:** Tightening torque of “F” adjuster locknut - 20 to 25 Nm

Where measurements are critical request certified drawings. We reserve the right to change specifications without notice.



# 1CEL90 - Overcenter Valve

Counterbalance, pilot assisted relief with check  
 90 L/min (23 USgpm) • 280 bar (4000 psi)

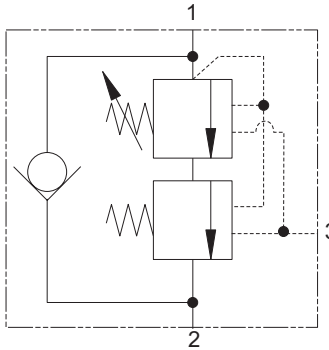

## Operation

The check section allows free flow and then locks the load against movement. The pilot assisted relief valve section will give controlled movement when pilot pressure is applied, maintaining a counterbalance pressure to prevent initial

pressure loss and therefore instability. The total pressure setting will normally be set at 1.3 times the load induced pressure. The counterbalance pressure reduces as the pilot pressure increases.

## Features

Cartridge is economical and fits simple cavity. Allows quick, easy field service - reduces down time. Interchangeable with pilot check valve of a similar size.

## Pilot Ratio

Primary 5.6:1  
 Secondary 0.7:1

## Performance Data

### Ratings and Specifications

Figures based on: Oil Temp = 40°C Viscosity = 32 cSt (150 SUS)

Rated flow	90 L/min (23 USgpm)
Maximum setting	380 bar (5510 psi)
Max load induced pressure	280 bar (4000 psi)
Cartridge material	Working parts hardened and ground steel. External surfaces zinc plated.
Standard housing material	Aluminum (up to 210 bar). Add suffix "377" for steel option.
Mounting position	Unrestricted
Cavity number	A12336 (See Section M)
Torque cartridge into cavity	60 Nm (44 ft. lbs.)
Weight	1CEL90 0.29 kg (0.63 lbs.) 1CEL95 1.35 kg (2.97 lbs.) 1CEEL95 2.10 kg (4.62 lbs.)
Seal kit number	SK633 (Nitrile) SK633V (Viton®)
Recommended filtration level	BS5540/4 Class 18/13 (25 micron nominal)
Operating temperature	-30° C to +90° C (-22° to +194°F)
Internal leakage	0.3 milliliters/min nominal (5 dpm)
Nominal viscosity range	5 to 500 cSt

Viton is a registered trademark of E.I. DuPont

## Sectional View

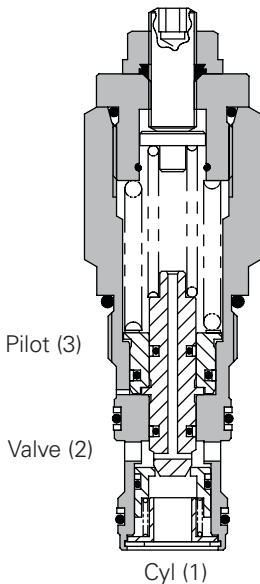

## Description

The 1CEL overcenter valve performs all duties of a regular overcenter but maintains a counterbalance pressure to provide dampening of cylinders when there is a rapid loss in stored pressure. This counterbalance pressure reduces as the pilot pressure increases. Typical applications include extension cylinders on telescopic handlers where it is important to have a smooth operation when retracting from full extension.

## Pressure Drop

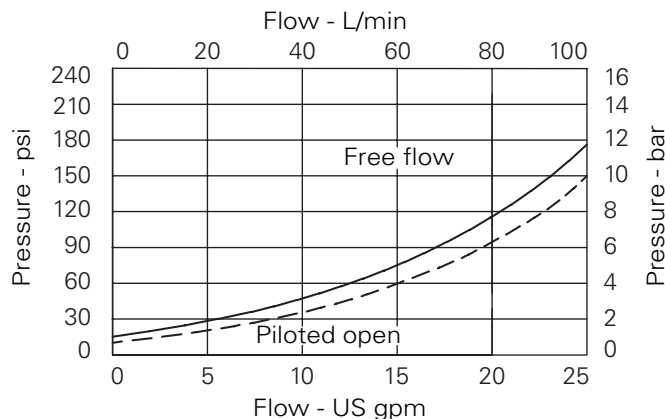

**Note:** This valve has been designed to eliminate instability from flexible boom applications or where the load induced pressure varies greatly. To get the best results, the settings should be adjusted for each application and then factory set for production quantities. Please contact our Technical Department for more information.

Where measurements are critical request certified drawings. We reserve the right to change specifications without notice.

# ICEL90 - Overcenter Valve

Counterbalance, pilot assisted relief with check  
90 L/min (23 USgpm) • 280 bar (4000 psi)

<b>Model Code</b>	<b>1CE*** - F</b>	<b>4W - 30</b>	<b>S</b>	<b>220 / 60</b>			
	<span style="border: 1px solid black; padding: 2px;">1</span>	<span style="border: 1px solid black; padding: 2px;">2</span>	<span style="border: 1px solid black; padding: 2px;">3</span>	<span style="border: 1px solid black; padding: 2px;">4</span>	<span style="border: 1px solid black; padding: 2px;">5</span>	<span style="border: 1px solid black; padding: 2px;">6</span>	<span style="border: 1px solid black; padding: 2px;">7</span>

## 1 Function

**1CEL90** - Cartridge Only  
**1CEL95** - Cartridge and Body  
**1CEEL95** - Cartridges and Dual Body

## 2 Adjustment Means Counterbalance Setting

**F** - Screw Adjustment  
**N** - Fixed - State pressure setting required.

For fixed versions add setting in 10 bar increments to end of part number. Subject to a ±10% tolerance.

## 3 Port Sizes

Code	Port Size	Housing Number - Body Only			
		Aluminium Single	Steel Single	Aluminium Dual	Steel Dual
4W	1/2" BSP Valve & Cyl Port 1/4" BSP Pilot Port	B13625	B13626	C13627	C13628
8T	1/2" SAE Valve & Cyl Port 1/4" SAE Pilot Port	B10806	B10922	C10807	C11561

## 4 Pressure range bar @ 4.8 L/min

**Note:** Code based on pressure in bar.

**20** - 170-350 Standard  
220 (160/60)

**30** - 210-380  
Standard 280 (220/60).

Standard setting made at 4.8 L/min

## 5 Seals

**S** - Nitrile (for use with most industrial hydraulic coils)

**SV** - Viton (for high temperature and most special fluid applications)

## 6 High Pressure Setting Bar

(10 bar increments)  
150 to 230 bar (2175 to 3335 psi)

## 7 Counterbalance Setting Bar

(10 bar increments)  
20 to 170 bar (300 tp 250 psi)

## Dimensions

mm (inch)

### Cartridge only

Basic Code  
1CEL90

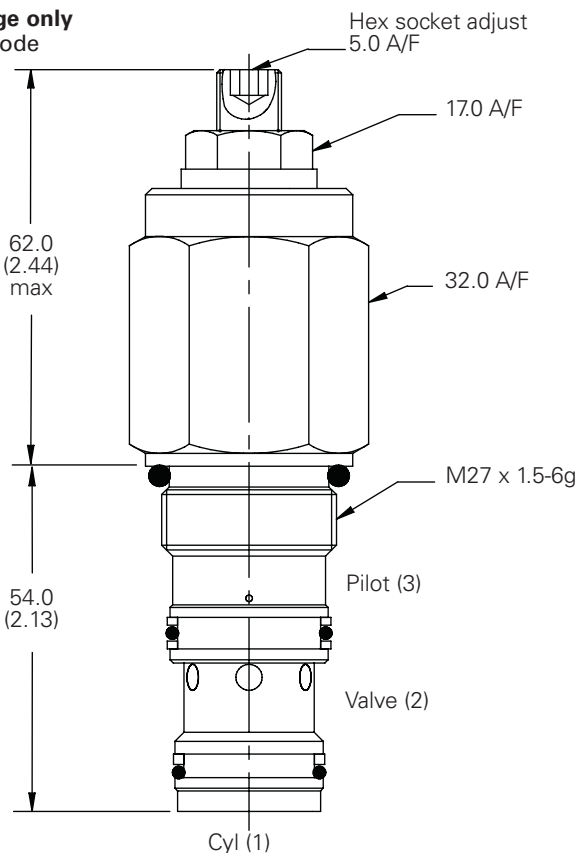

**Note:** For applications above 210 bar, please consult our technical department or use the steel body option.

**Note:** Tightening torque of "F" adjuster locknut - 20 to 25 Nm.

### Single Valve 1/2" Ports Basic Code 1CEL95

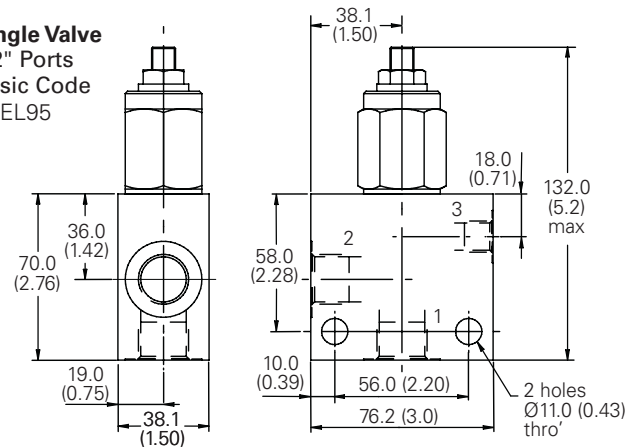

### Dual Valve 1/2" Ports Basic Code 1CEEL95 Internally Cross Piloted)

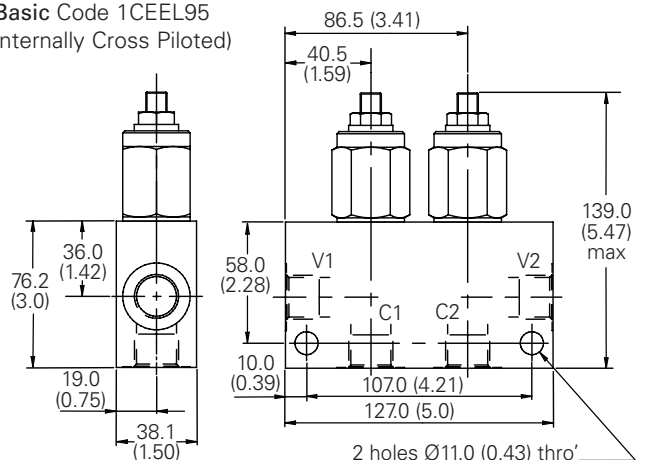

Where measurements are critical request certified drawings. We reserve the right to change specifications without notice.

# ICPPD90 - Piloted Bi-directional Poppet Valve

Poppet, pilot operated, normally closed, zero differential  
 90 L/min (23 USgpm) • 350 bar (5000 psi)

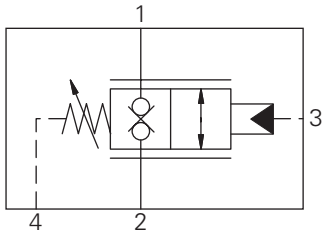

Sectional View

## Operation

By the application of pilot pressure to the pilot port the poppet moves back against the main spring opening. The metering characteristic of the valve is controlled by the rate of the spring, the seat angle and the pilot pressure applied.

Due to the balanced poppet design load induced pressure will not open the valve and once open valve port pressure will not increase the pilot pressure required to keep the valve open.

## Features

The cartridge fits a simple cavity allowing quick, easy field service reducing down time. Hardened poppet and seat provide for long leak free performance.

## Performance Data

### Ratings and Specifications

Figures based on: Oil Temp = 40°C Viscosity = 32 cSt (150 SUS)

Rated flow	90 L/min (23 USgpm)
Maximum working pressure	350 bar (5000 psi)
Cartridge material	Working parts hardened and ground steel. External surfaces Nickel/ Zinc plated.
Mounting position	Unrestricted
Cavity number	A12196 (See Section M)
Torque cartridge into cavity	60 Nm (44 ft. lbs.)
Weight	0.37kg (0.82lbs.)
Seal kit number	SK1453 (Nitrile) SK1453V (Viton*) SK1453P (Polyurethane/Nitrile)
Recommended filtration level	BS5540/4 Class 18/13 (25 micron nominal)
Temperature	-30° C to +90° C (-22° to +194°F)
Internal leakage	0.3 milliliters/min nominal (5 dpm)
Nominal viscosity range	5 to 500 cSt

Viton is a registered trademark of E.I. DuPont

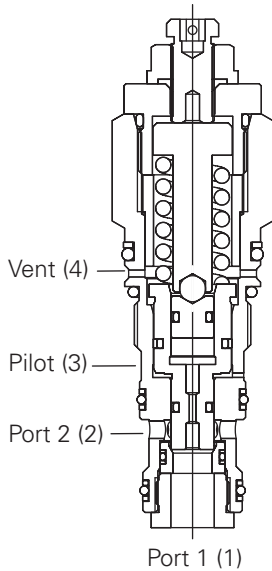

F

## Application

Normally closed pilot operated zero differential bi-directional poppet valve providing flow control by application of pilot pressure to actuate the poppet and increase the flow path.

Balanced construction ensures predictable switching regardless of pressure in port 1 or 2. The drain line allows the valve to be used in corrosive atmospheres preventing the ingress of atmospheric contamination.

## Pilot open pressure drop - both directions

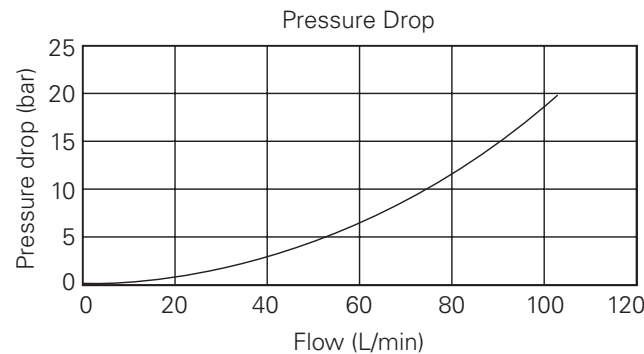

Where measurements are critical request certified drawings. We reserve the right to change specifications without notice.

# 1CPPD90 - Piloted Bi-directional Poppet Valve

Poppet, pilot operated, normally close, zero differential  
 90 L/min (23 USgpm) • 350 bar (5000 psi)

## Model Code

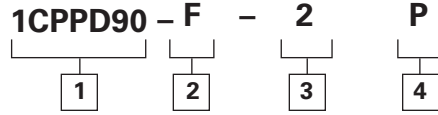

### 1 Function

**1CPPD90** - Cartridge Only

### 2 Adjustment Means

- F** - Screw Adjustment
- G** - Tamperproof Cap
- N** - Fixed - State pressure setting required

### 3 Pilot Adjustment Range @ 4.8 L/min

**Note:** Code based on pressure in bar.

**2** - 8 - 25 bar.

Standard setting: 10 bar

Standard setting made at 4.8 L/min

### 4 Seals

- S** - Nitrile (for use with most industrial hydraulic coils).
- SV** - Viton® (for high temperature and most special fluid applications).
- P** - Polyurethane/Nitrile (for arduous applications)

Line body available on request.

## Dimensions

mm (inch)

### Cartridge Only

Basic Code

1CPPD90

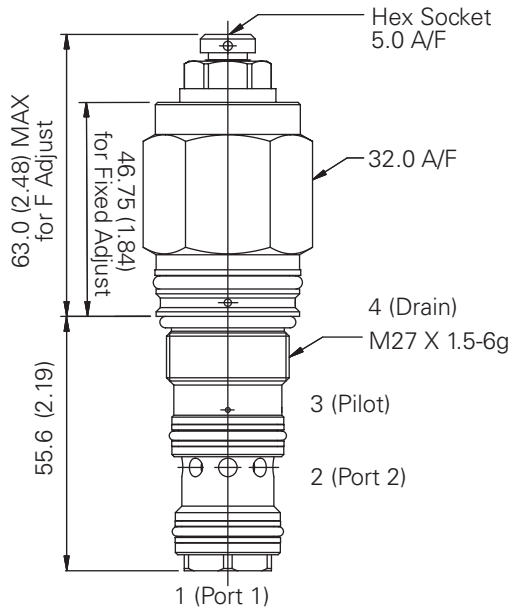

**Note:** Tightening torque of "F" adjuster locknut - 20 to 25 Nm



# ICE120 - Overcenter Valve

Pilot assisted relief with check

120 L/min (32 USgpm) • 270 bar (4000 psi)

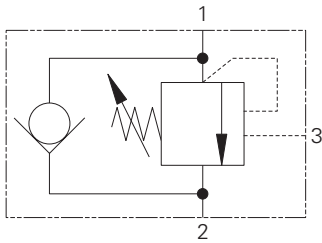

## Sectional View

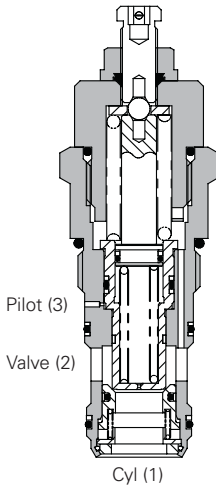

## Description

Overcenter valves give static and dynamic control of loads by regulating the flow into and out of hydraulic actuators. When installed close to or within an actuator, the overcenter valve will stop runaway in the event of hose burst and if open center directional control valves are used, will allow thermal expansion relief of the hydraulic fluid.

The overcenter cartridge is ideal for mounting directly into a cavity machined in the body of the cylinder, motor or rotary actuator. The cartridge can also be mounted directly to the ports via a specifically machined body as part of a Hydraulic Integrated Circuit or single unit, or contained within one of our standard line bodies.

Single overcenter valves are normally used when the load is unidirectional, for example an aerial platform or crane and dual overcenter valves are used for controlling loads in both directional for motor applications or for cylinders going over center.

## Operation

The check section allows free flow into the actuator then holds and locks the load against movement. The pilot assisted relief valve section will give controlled movement when pilot pressure is applied. The relief section is normally set to open at a pressure at least 1.3 times the maximum load induced pressure but the

pressure required to open the valve and allow movement depends on the pilot ratio of the valve. For optimization of load control and energy usage, a choice of pilot ratios is available

The pressure required to open the valve and start actuator movement can be calculated as follows:

$$\text{Pilot Pressure} = \frac{(\text{Relief Setting}) - (\text{Load Pressure})}{\text{Pilot Ratio}}$$

## Features

Cartridge is economical and fits simple cavity. Allows quick, easy field service - reduces down time. Interchangeable with pilot check valve of a similar size.

## Pilot Ratio

3.5:1 (standard) Best suited for applications where load varies and machine structure can induce instability.

8:1 Best suited for applications where the load remains relatively constant.

## Performance Data

### Ratings and Specifications

Figures based on: Oil Temp = 40°C Viscosity = 32 cSt (150 SUS)

Rated flow	120 L/min (32 USgpm)
Max relief setting	350 bar (5000 psi)
Max load induced pressure	270 bar (4000 psi)
Cartridge material	Working parts hardened and ground steel. External surfaces zinc plated.
Standard housing material	Aluminum (up to 210 bar). Add suffix "377" for steel option.
Mounting position	Unrestricted
Cavity number	A877 (See Section M)
Torque cartridge into cavity	100 Nm (74 lbs ft)
Weight	1CE120 0.59 kg (1.30 lbs) 1CE150 1.46 kg (3.20 lbs) 1CEE150 2.58 kg (5.70 lbs)
Seal kit number	SK417 (Nitrile) SK417V (Viton®)
Recommended filtration level	BS5540/4 Class 18/13 (25 micron nominal)
Operating temperature	-30°C to +90°C (-22° to +194°F)
Leakage	0.3 milliliters/min nominal (5 dpm)
Nominal viscosity range	5 to 500 cSt

Viton is a registered trademark of E.I. DuPont

## Pressure Drop

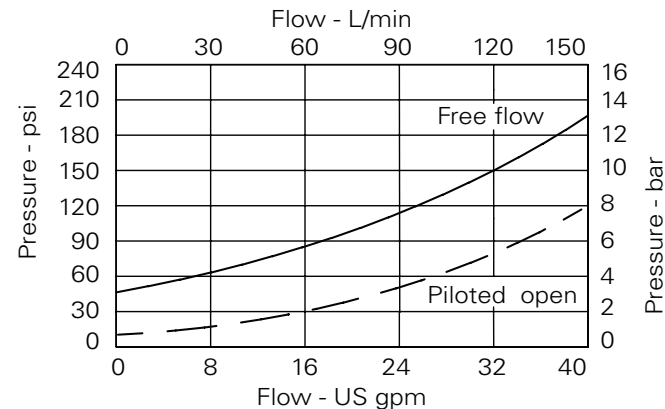

Where measurements are critical request certified drawings. We reserve the right to change specifications without notice.

# ICE120 - Overcenter Valve

Pilot assisted relief with check

120 L/min (32 USgpm) • 270 bar (4000 psi)

## Model Code

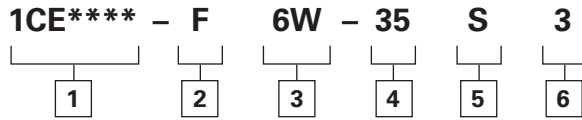

### 1 Function

**1CE120** - Cartridge Only  
**1CE150** - Cartridge and Body  
**1CEE150** - Cartridges and Dual Body

### 2 Adjustment Means

**F** - Screw Adjustment

### 3 Port Sizes

Code	Port Size	Housing Number			
		Aluminium Single	Steel Single	Aluminium Dual	Steel Dual
6W	3/4" BSP Valve & Cyl Port. 1/4" BSP Pilot Port	B6898	B5544	C2543	C1200
12T	3/4" SAE Valve & Cyl Port. 1/4" SAE Pilot Port	B8200		C10629	C16434
16T	1" SAE Valve & Cyl Port. 1/4" SAE Pilot Port	B10708	B11814		

### 4 Pressure Range @ 4.8 l/min

**Note:** Code based on pressure in bar.

**35** - 70-350 bar.

Std setting 210 bar

Std setting made at 4.8 L/min

### 5 Seals

**S** - Nitrile (For use with most industrial hydraulic oils)

**SV** - Viton (For high temperature and most special fluid applications)

### 6 Pilot Ratio

**3** - 3.5:1

**8** - 8:1

## Dimensions

mm (inch)

### Cartridge Only

Basic Code  
ICE120

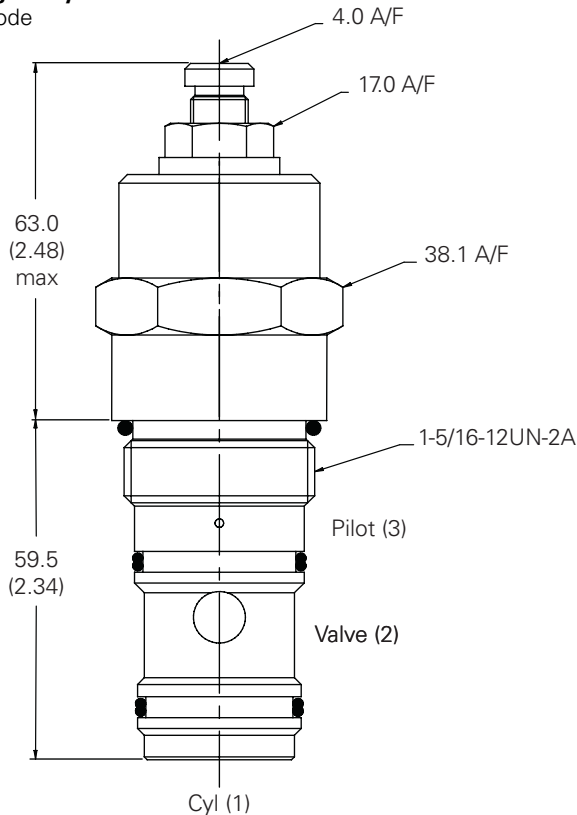

**Note:** Tightening torque of "F" adjuster locknut - 20 to 25 Nm.

**Note:** For applications above 210 bar - please consult our technical department or use the steel body option.

### Single Valve

3/4", 1" Ports  
Basic Code  
1CE150

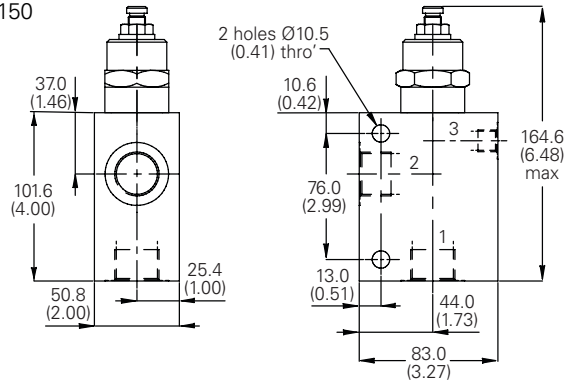

### Dual Valve

3/4"  
Basic Code 1CEE150  
Internally Cross Piloted

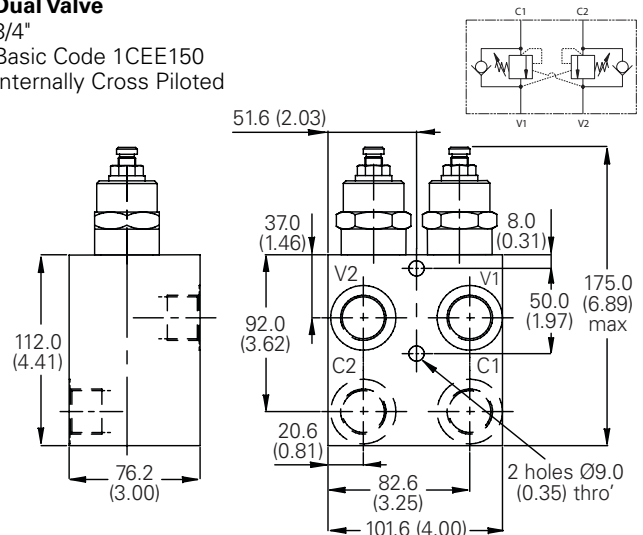

Where measurements are critical request certified drawings. We reserve the right to change specifications without notice.

# ICEB120 - Overcenter Valve

Fully balanced, pilot assisted relief with check  
120 L/min (32 USgpm). 270 bar (4000 psi)

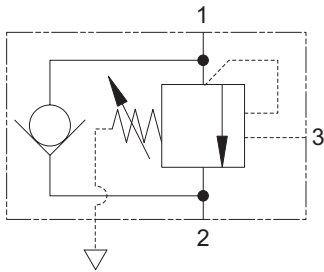

## Operation

The check section allows free flow into the actuator then holds and locks the load against movement. The pilot assisted relief valve section will give controlled movement when pilot pressure is applied. The relief section is normally set to open at a pressure at least 1.3 times the maximum load induced pressure but the pressure required to open the

valve and allow movement depends on the pilot ratio of the valve. For optimization of load control and energy usage, a choice of pilot ratios is available.

The pressure required to open the valve and start actuator movement can be calculated as follows:

$$\text{Pilot Pressure} = \frac{(\text{Relief Setting}) - (\text{Load Pressure})}{\text{Pilot Ratio}}$$

## Features

Cartridge is economical and fits simple cavity. Allows quick, easy field service - reduces down time. Interchangeable with pilot check valve of a similar size.

## Pilot Ratio

3:1 (standard) Best suited for applications where load varies and machine structure can induce instability.

8:1 Best suited for applications where the load remains relatively constant.

## Sectional View

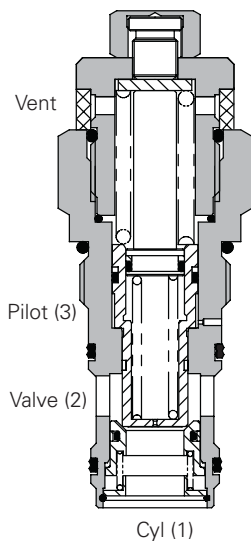

F

## Performance Data

### Ratings and Specifications

Figures based on: Oil Temp = 40°C Viscosity = 32 cSt (150 SUS)

Rated flow	120 L/min (32 USgpm)
Max relief setting	350 bar (5000 psi)
Max load induced pressure	270 bar (4000 psi)
Cartridge material	Working parts hardened and ground steel. External surfaces zinc plated.
Standard housing material	Aluminum (up to 210 bar). Add suffix "377" for steel option.
Mounting position	Unrestricted
Cavity number	A877 (See Section M)
Torque cartridge into cavity	100 Nm (74 lbs ft)
Weight	1CEB120 0.59 kg (1.30 lbs) 1CEB150 1.46 kg (3.20 lbs) 1CEEB150 2.58 kg (5.70 lbs)
Seal kit number	SK417 (Nitrile) SK417V (Viton®)
Recommended filtration level	BS5540/4 Class 18/13 (25 micron nominal)
Operating temperature	-30° to +90°C (-22° to +194°F)
Leakage	0.3 milliliters/min nominal (5 dpm)
Nominal viscosity range	5 to 500 cSt

Viton is a registered trademark of E.I. DuPont

## Description

Overcenter valves give static and dynamic control of loads by supplying a counterbalance pressure to the actuator. They prevent runaway in the event of hose burst and hold the load with minimal leakage.

The pressure balanced valve is unaffected by back pressure, allowing service line reliefs to operate and for the valve to be used in regenerative or proportional valve systems.

The overcenter valve should be mounted either into, onto or as close to the actuator as possible to give maximum protection.

Single overcenter valves control unidirectional loads such as in aerial platforms, cranes or winches and dual overcenters are suited to bi-directional motion such as wheel motor applications or cylinders going over center.

## Pressure Drop

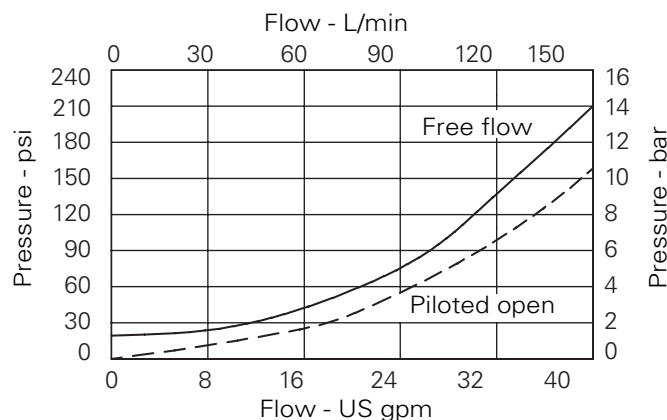

Where measurements are critical request certified drawings. We reserve the right to change specifications without notice.

# ICEB120 - Overcenter Valve

Fully balanced, pilot assisted relief with check  
120 L/min (32 USgpm). 270 bar (4000 psi)

## Model Code

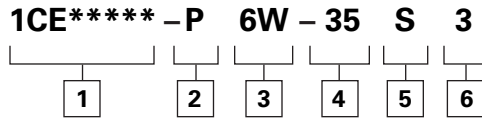

### 1 Function

**1CEB120** - Cartridge only  
**1CEB150** - Cartridge in body  
**1CEEB150** - Cartridges in dual body

### 2 Adjustment Means

**P** - Leakproof screw adjustment

### 3 Port Sizes

Code	Port Size	Housing Number - Body Only			
		Aluminium Single	Steel Single	Aluminium Dual	Steel Dual
<b>6W</b>	3/4" BSP Valve & Cyl Port. 1/4" BSP Pilot Port	B6898	B5544	C2543	C1200
<b>12T</b>	3/4" SAE Valve & Cyl Port. 1/4" SAE Pilot Port	B8200		C10629	C16434
<b>16T</b>	1" SAE Valve & Cyl Port. 1/4" SAE Pilot Port	B10708	B11814		

### 4 Pressure Range @ 4.8 l/min

**Note:** Code based on pressure in bar.

**35** - 70-350 bar.  
Std setting 210 bar  
Std setting made at 4.8 L/min

### 5 Seals

**S** - Nitrile (For use with most industrial hydraulic oils)

**SV** - Viton (For high temperature and most special fluid applications)

**P** - Polyurethane/Nitrile (For arduous applications)

### 6 Pilot Ratio

**3** - 3:1 (Standard)  
**8** - 8:1

## Dimensions

mm (inch)

### Cartridge Only

Basic Code  
ICEB120

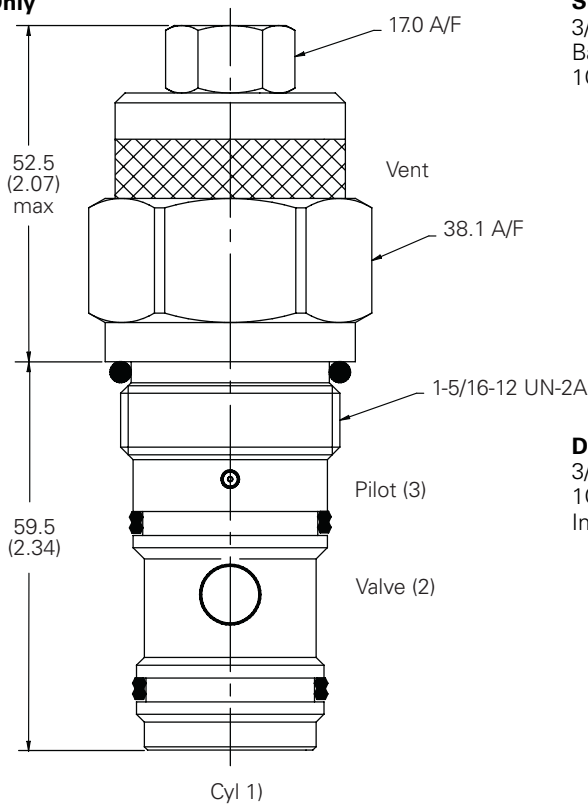

**Note:** For applications above 210 bar - please consult our technical department or use the steel body option

**Note:** Tightening torque of "F" adjuster locknut - 20 to 25 Nm.

### Single Valve

3/4", 1" Ports  
Basic Code  
1CEB150

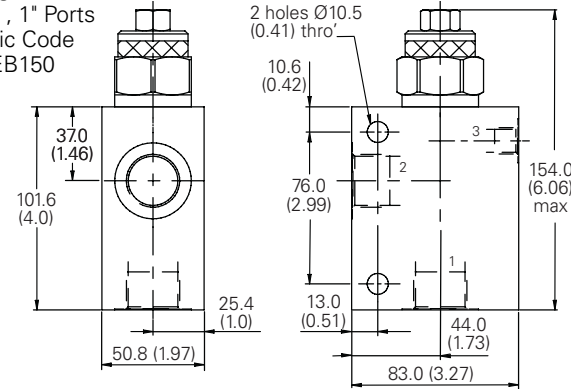

### Dual Valve

3/4" Ports  
1CEEB150  
Internally Cross Piloted

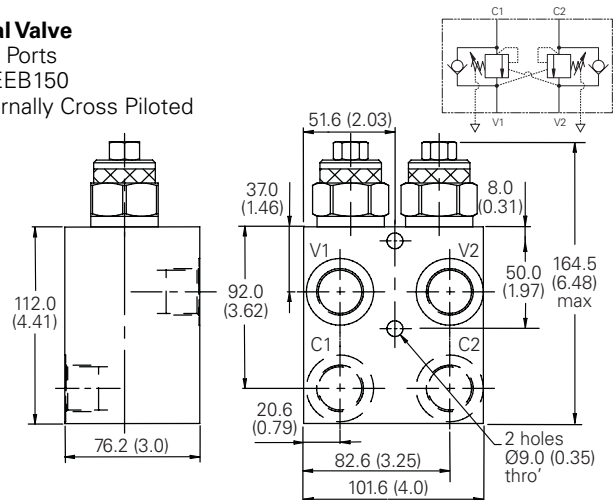

Where measurements are critical request certified drawings. We reserve the right to change specifications without notice.

# ICEBD120 - Overcenter Valve

Fully balanced, pilot assisted relief with check  
180 L/min (47 USgpm) • 270 bar (4000 psi)

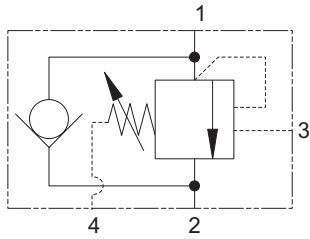

## Sectional View

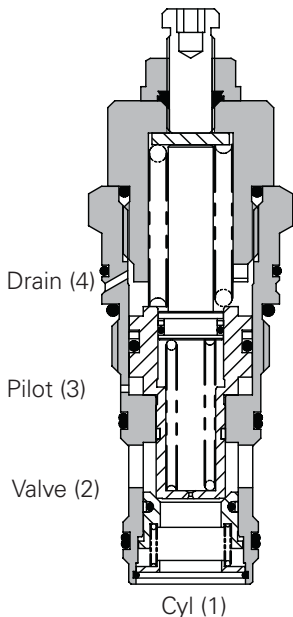

## Description

Overcenter valves give static and dynamic control of loads by supplying a counterbalance pressure to the actuator. They will stop runaway in the event of hose burst and hold the load with minimal leakage.

The pressure balanced overcenter relief setting is unaffected by back pressure, enabling the valve to stay open when the valve port pressure rises. This will allow service line reliefs to work normally and will also allow the control of regenerative or proportional systems. The drain line allows the valve to be used in corrosive atmospheres preventing the ingress of atmospheric contaminant.

Single overcenter valves are normally used when the load is unidirectional, for example an aerial platform or crane and dual overcenter valves are used for controlling loads in both directional for motor applications or for cylinders going over center.

## Operation

The check section allows free flow into the actuator then holds and locks the load against movement. The pilot assisted relief valve section will give controlled movement when pilot pressure is applied. The relief section is normally set to open at a pressure at least 1.3 times the maximum load induced pressure but the pressure required to open the

valve and allow movement depends on the pilot ratio of the valve. For optimization of load control and energy usage, a choice of pilot ratios is available.

The pressure required to open the valve and start actuator movement can be calculated as follows:

$$\text{Pilot Pressure} = \frac{(\text{Relief Setting}) - (\text{Load Pressure})}{\text{Pilot Ratio}}$$

## Features

Cartridge is economical and fits simple cavity. Allows quick, easy field service - reduces down time.

## Pilot Ratio

3:1 (standard) Best suited for applications where load varies and machine structure can induce instability.

8:1 & 12:1 Best suited for applications where the load remains relatively constant.

22:1 Specifically designed for Boom Loc applications.

## Performance Data

### Ratings and Specifications

Figures based on: Oil Temp = 40°C Viscosity = 32 cSt (150 SUS)

Rated flow	180 L/min (47 USgpm)
Max relief setting	400 bar (5800 psi)
Max load induced pressure	270 bar (4000 psi)
Cartridge material	Working parts hardened and ground steel. External surfaces electroless nickel plated.
Mounting position	Unrestricted
Cavity number	A6726 (See Section M)
Torque cartridge into cavity	100 Nm (74 lbs ft)
Weight	0.59 kg (1.30 lbs)
Seal kit number	SK830 (Nitrile) SK830V (Viton®) SK830P (Polyurethane/Nitrile)
Recommended filtration level	BS5540/4 Class 18/13 (25 micron nominal)
Operating temperature	-30°C to +90°C (-22° to +194°F)
Leakage	0.3 milliliters/min max (5 dpm)
Nominal viscosity range	5 to 500 cSt
Bar per turn	65 bar

Viton is a registered trademark of E.I. DuPont

## Pressure Drop

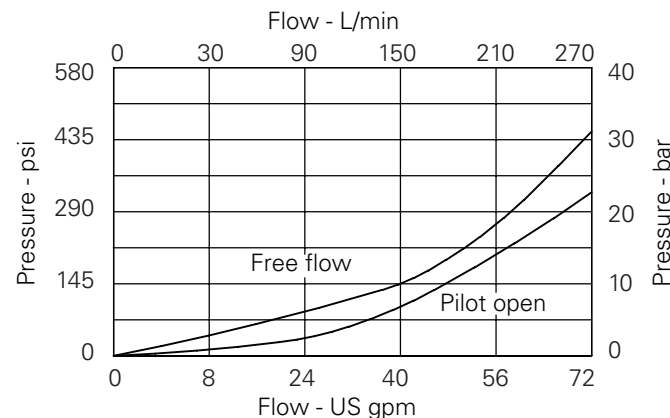

Where measurements are critical request certified drawings. We reserve the right to change specifications without notice.

# ICEBD120 - Overcenter Valve

Fully balanced, pilot assisted relief with check  
180 L/min (47 USgpm) • 270 bar (4000 psi)

## Model Code

**1CEBD120 – F – 35 P 8**

1   
 2 3   
 4 5

**1 Function**  
1CEBD120 - Cartridge only

**2 Adjustment Means**  
F - Screw adjustment

**3 Pressure Range @ 4.8 l/min**  
**Note:** Code based on pressure in bar.

**35** - (3:1, 8:1 and 22:1):  
70-350 bar  
Std setting 350 bar

**40** - (12:1): 70-400 bar.  
Std setting 350 bar  
Std setting made at 4.8 L/min

**5 Seals**

**S** - Nitrile (For use with most industrial hydraulic oils)

**SV** - Viton (For high temperature and most special fluid applications)

**P** - Polyurethane/Nitrile (For arduous applications)

**6 Pilot Ratio**

**3** - 3:1  
**8** - 8:1  
**12** - 12:1  
**22** - 22:1

## Dimensions

mm (inch)

### Cartridge Only

Basic Code  
**1CEBD120**

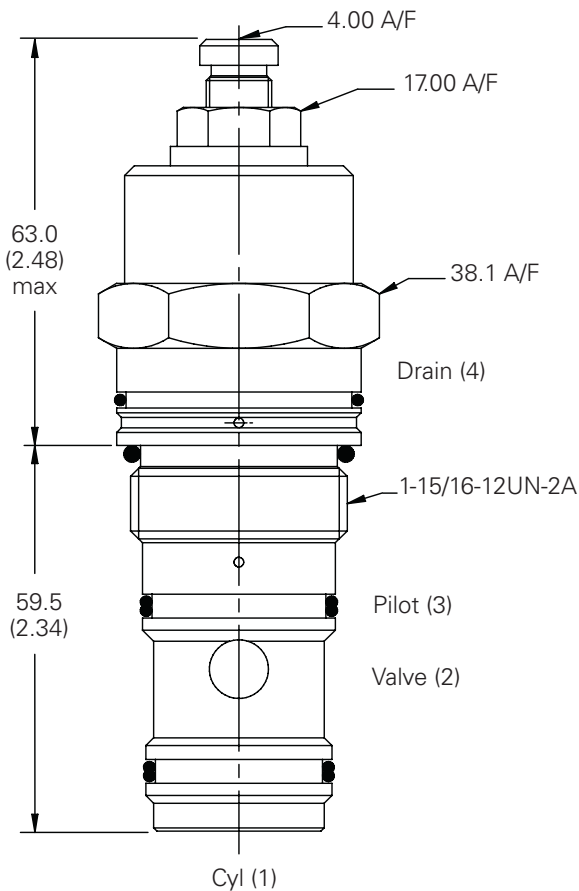

**Note:** For applications above 210 bar - please consult our technical department or use the steel body option

**Note:** Tightening torque of "F" adjuster locknut - 20 to 25 Nm

Where measurements are critical request certified drawings. We reserve the right to change specifications without notice.



# ICPBD120 - Overcenter Valve

Zero differential with check

180 L/min (47 USgpm) • 400 bar (5800 psi)

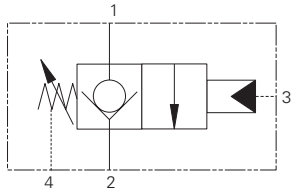

## Sectional View

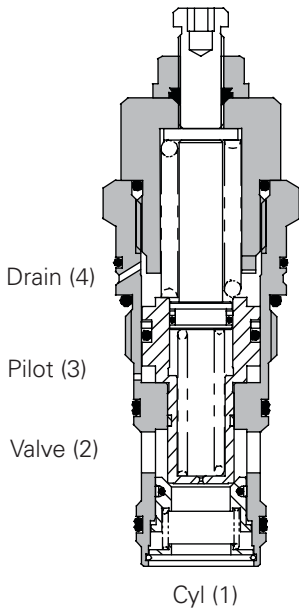

## Operation

The check section allows free flow into the actuator then holds and locks the load against movement. By the application of pilot pressure to the pilot port the poppet moves back against the main spring opening the cylinder port to the valve port. The metering characteristic of the valve is controlled by the rate

of the spring, the seat angle and the pilot pressure applied.

Due to the balanced poppet design load induced pressure will not open the valve and once open valve port pressure will not increase the pilot pressure required to keep the valve open.

## Features

The cartridge fits a simple cavity allowing quick, easy field service reducing down time. Hardened poppet and seat provide for long leak free performance.

## Performance Data

### Ratings and Specifications

Figures based on: Oil Temp = 40°C Viscosity = 32 cSt (150 SUS)

Rated flow	180 L/min (47 USgpm)
Max working pressure	400 bar (5800 psi)
Cartridge material	Working parts hardened and ground steel. External surfaces zinc plated.
Mounting position	Unrestricted
Cavity number	A6726 (See Section M)
Torque cartridge into cavity	100 Nm (74 lbs ft)
Weight	0.59 kg (1.30 lbs)
Seal kit number	SK830 (Nitrile) SK830V (Viton®) SK830P (Polyurethane/Nitrile)
Recommended filtration level	BS5540/4 Class 18/13 (25 micron nominal)
Operating temperature	-30° to +90°C (-22° to +194°F)
Leakage	0.3 milliliters/min max (5 dpm)
Nominal viscosity range	5 to 500 cSt
Bar per turn	5 bar

Viton® is a registered trademark of E.I. DuPont

## Description

Zero differential overcenter valves give static and dynamic control of loads by supplying a restriction to flow related to the opening of the valve created by the pilot pressure.

The valve is used in conjunction with a remote pilot source to provide hose failure protection, load control and load holding functions.

If over-pressure or shock pressure protection is required then a separate relief valve should be used.

The drain line allows the valve to be used in corrosive atmospheres preventing the ingress of atmospheric contaminant.

## Pressure Drop

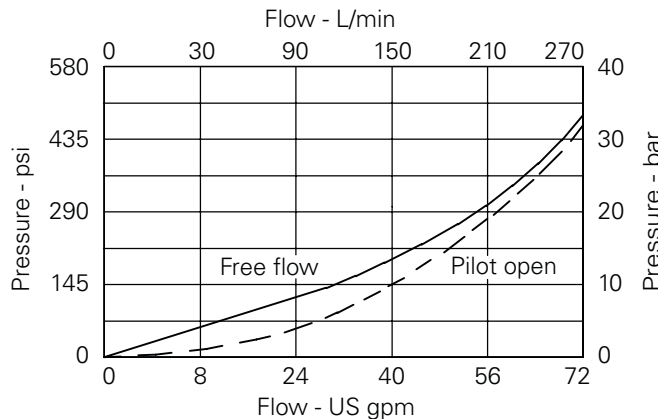

Where measurements are critical request certified drawings. We reserve the right to change specifications without notice.

# 1CPBD120 - Overcenter Valve

Zero differential with check

180 L/min (47 USgpm) • 400 bar (5800 psi)

Model Code

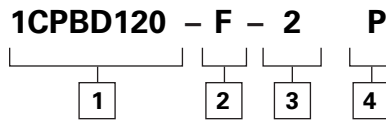

1 Function 1CPBD120 - Cartridge only	2 Adjustment Means F - Screw adjustment	3 Pilot Adjust Range <b>Note:</b> Code based on pressure in bar. 2 - 5-20 bar. Std setting 10 bar Std setting made at 4.8 L/min	4 Seals <b>S</b> - Nitrile (For use with most industrial hydraulic oils) <b>SV</b> - Viton (For high temperature and most special fluid applications) <b>P</b> - Polyurethane/Nitrile (For arduous applications)
---	--	---	---

## Dimensions

mm (inch)

### Cartridge Only

Basic Code  
1CPBD120

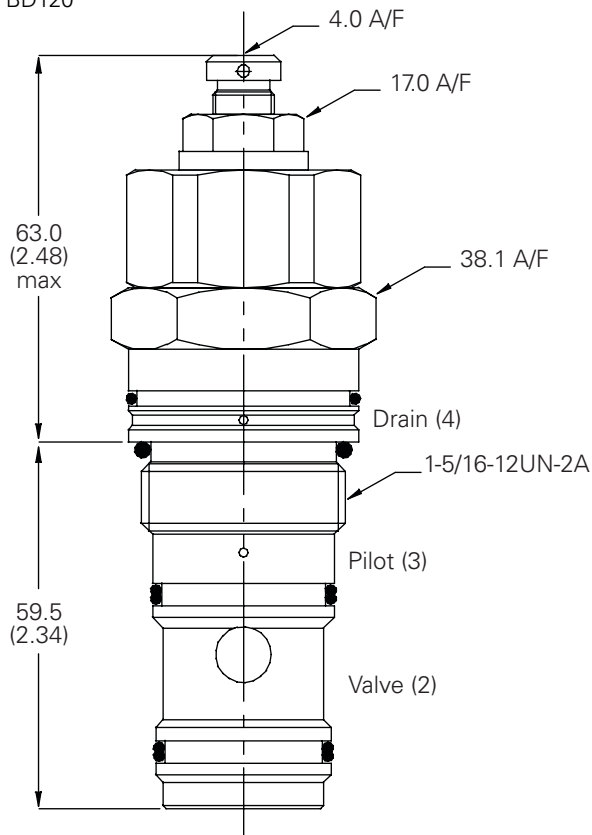

**Note:** Tightening torque of "F" adjuster locknut - 20 to 25 Nm.



# ICE - Overcenter Valve

Alternative body arrangements  
for 100 Liters/min Valves

## Model Code

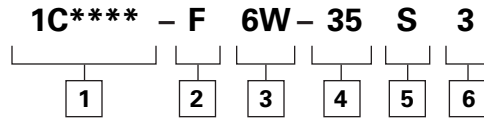

### 1 Function

**1CE156/1CEB156** - Cartridge & Body Through Ported

#### 1CBE150/1CBEB150

- Cartridge & Body Banjo Mounted

#### 1CEG150/1CEBG150

- Cartridge & Body Gasket Mounted

### 2 Adjustment Means

**P** - Leakproof Screw Adjust (1CEB156/1CBEB150/1CEBG150)

**F** - Screw Adjust (1CE156/1CEB150/1CEG150)

### 3 Port Sizes

Code	Port Size	Housing Number - Body Only	
		Aluminum	Steel
1CE156/1CE156 Complete Valve Body ONLY part numbers			
<b>6W</b>	3/4" BSP Valve & Cyl Port. 1/4" BSP Pilot Port	B13629	B13630
1CBE150/1CBEB150 Sub-assembly part numbers			
<b>6W</b>	3/4" BSP Valve & Cyl Port. 1/4" BSP Pilot Port	AXP13565-6W-S	
1CEG150/1CEBG150 Gasket Mounted numbers			
<b>6W</b>	3/4" SAE 6000 PSI Flange Ports	BXP13634-6W-S	BXP13634-6W-S-377

### 4 Pressure Range @ 4.8 l/min

**Note:** Code based on pressure in bar.

**35** - 70-350 bar.  
Std setting 210 bar  
Std setting made at 4.8 L/min

### 5 Seals

**S** - Nitrile (For use with most industrial hydraulic oils)

**SV** - Viton (For high temperature and most special fluid applications)

**P** - Polyurethane/Nitrile (For arduous applications)

### 6 Pilot Ratio

**3** -3.5:1 - 1CE156/1CBE150/1CEG150

**3** -3:1 - 1CEB156/1CBEB150/1CEBG150 (Standard)

**8** - 8:1 - 1CEB156/1CBEB150/1CEBG150

**F**

# ICE - Overcenter Valve

Alternative body arrangements  
for 100 Liters/min Valves

## Dimensions

mm (inch)

### Complete Valve

Through Ported

3/4" Ports

Basic Code

1CE156/1CEB156

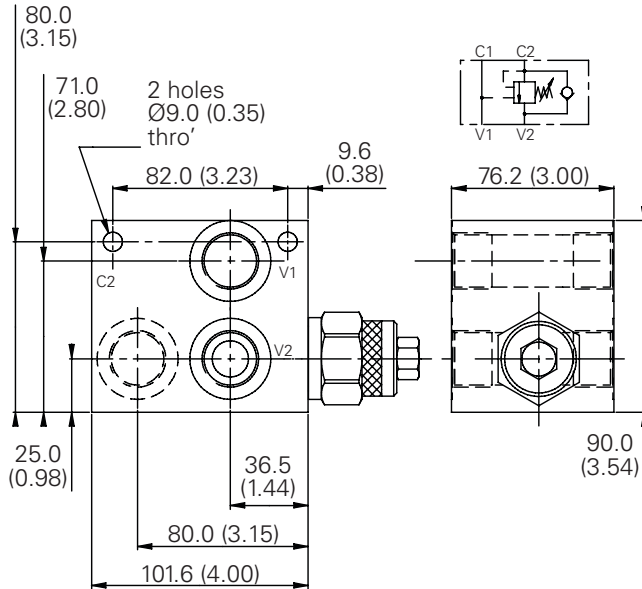

### Complete Valve

3/4" Ports

Banjo Mounted

Basic Code

1CBE150/1CBEB150

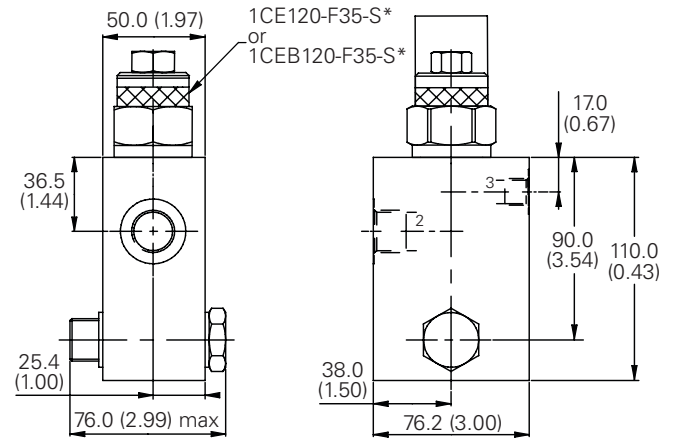

### Complete Valve

3/4" Ports SAE 6000 PSI Flange Ports

1CEG150/1CEBG150

Gasket Mounted

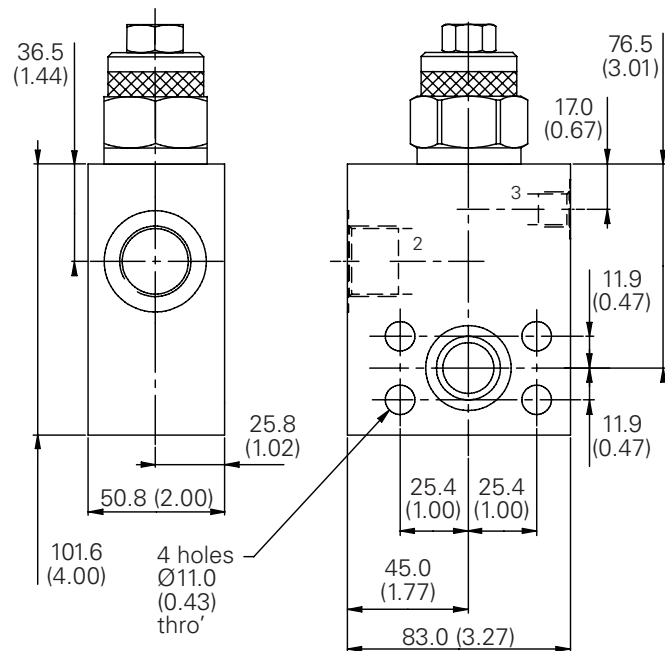

**Note:** Tightening torque of "F" adjuster locknut - 20 to 25 Nm.

**Note:** For applications above 210 please consult our Technical Department or use the steel body option.

Where measurements are critical request certified drawings. We reserve the right to change specifications without notice.

# ICE140 - Overcenter Valve

Pilot assisted relief with check

140 L/min (37 USgpm) • 340 bar (4930 psi)

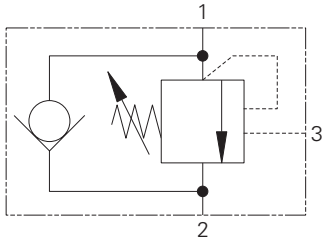

## Sectional View

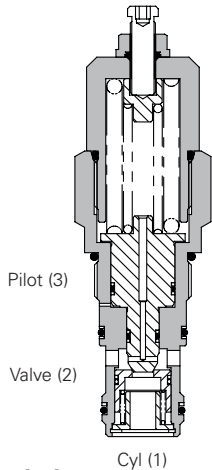

F

## Description

Overcenter valves give static and dynamic control of loads by regulating the flow into and out of hydraulic actuators. When installed close to or within an actuator, the overcenter valve will stop runaway in the event of hose burst and if open center directional control valves are used, will allow thermal expansion relief of the hydraulic fluid.

The overcenter cartridge is ideal for mounting directly into a cavity machined in the body of the cylinder, motor or rotary actuator. The cartridge can also be mounted directly to the ports via a specifically machined body as part of a Hydraulic Integrated Circuit or single unit, or contained within one of our standard line bodies.

Single overcenter valves are normally used when the load is unidirectional, for example an aerial platform or crane and dual overcenter valves are used for controlling loads in both directional for motor applications or for cylinders going over center.

Where measurements are critical request certified drawings. We reserve the right to change specifications without notice.

## Operation

The check section allows free flow into the actuator then holds and locks the load against movement. The pilot assisted relief valve section will give controlled movement when pilot pressure is applied. The relief section is normally set to open at a pressure at least 1.3 times the maximum load induced pressure but the pressure required to open the valve and allow movement

depends on the pilot ratio of the valve. For optimization of load control and energy usage, a choice of pilot ratios is available.

The pressure required to open the valve and start actuator movement can be calculated as follows:

$$\text{Pilot Pressure} = \frac{(\text{Relief Setting}) - (\text{Load Pressure})}{\text{Pilot Ratio}}$$

## Features

Cartridge is economical and fits simple cavity. Allows quick, easy field service - reduces down time. Interchangeable with pilot check valve of a similar size.

## Pilot Ratio

4:1 Best suited for applications where load varies and machine structure can induce instability.

6:1 Best suited for applications where the load remains relatively constant.

Other options available upon request.

## Performance Data

### Ratings and Specifications

Figures based on: Oil Temp = 40°C Viscosity = 32 cSt (150 SUS)

Rated flow	140 L/min (37 USgpm)
Max relief setting	420 bar (6090 psi)
Max load induced pressure	340 bar (4930 psi)
Cartridge material	Working parts hardened and ground steel. External surfaces zinc plated.
Standard housing material	Aluminum (up to 210 bar). Add suffix "377" for steel option.
Mounting position	Unrestricted
Cavity number	A20081
Torque cartridge into cavity	150 Nm (110 lbs ft)
Weight	1CE140 1.2 kg (2.5 lbs) 1CE145 (aluminium) 2.2 kg (4.5 lbs) 1CE145 (steel) 4.0 kg (8.8 lbs) 1CEE145 (aluminium) 2.9 kg (6.4 lbs) 1CEE145 (steel) 6.0 kg (13.2 lbs)
Seal kit number	SK1108 (Nitrile) SK1108V (Viton®)
Recommended filtration level	BS5540/4 Class 18/13 (25 micron nominal)
Operating temperature	-30°C to +90°C (-22° to +194°F)
Leakage	0.3 milliliters/min nominal (5 dpm)
Nominal viscosity range	5 to 500 cSt

Viton is a registered trademark of E.I. DuPont

## Pressure Drop

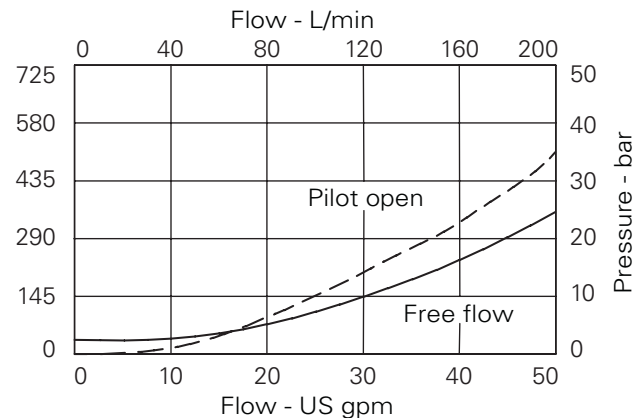

# ICE140 - Overcenter Valve

Pilot assisted relief with check

140 L/min (37 USgpm) • 340 bar (4930 psi)

## Model Code

**1CE\*\*\*\* - F 6W- 40 S 4**

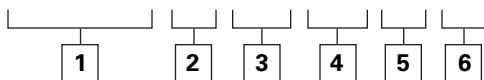

### 1 Function

- 1CE140** - Cartridge only
- 1CE145** - Cartridge and body
- 1CEE145** - Cartridges and body

### 2 Adjustment Means

**F** - Screw adjustment

### 3 Port Sizes

Code	Port Size	Housing Number - Body Only			
		Aluminium Single	Steel Single Dual	Aluminium Steel Dual	Steel Dual
<b>6W</b>	3/4" BSP Valve & Cyl Port. 1/4" BSP Pilot Port	B20105	B20106		
<b>8W</b>	1" BSP Valve & Cyl Port. 1/4" BSP Pilot Port	B20107	B20108 C20285		C20287
<b>16T</b>	1" SAE Valve & Cyl Port. 1/4" SAE Pilot Port	B11946	B11947 C30105		C30106

### 4 Pressure Range @ 4.8 l/min

**Note:** Code based on pressure in bar.

- 20** - 140-250 bar.  
Std setting 190 bar
  - 30** - 220-330 bar.  
Std setting 270 bar
  - 40** - 310-420 bar.  
Std setting 370 bar
- Std setting made at 4.8 liter/min

### 5 Seals

- S** - Nitrile (For use with most industrial hydraulic oils)
- SV** - Viton (For high temperature and most special fluid applications)

### 6 Pilot Ratio

- 4** - 4:1
  - 6** - 6:1
- Other ratios available upon request

## Dimensions

mm (inch)

### Cartridge Only

Basic Code  
1CE140

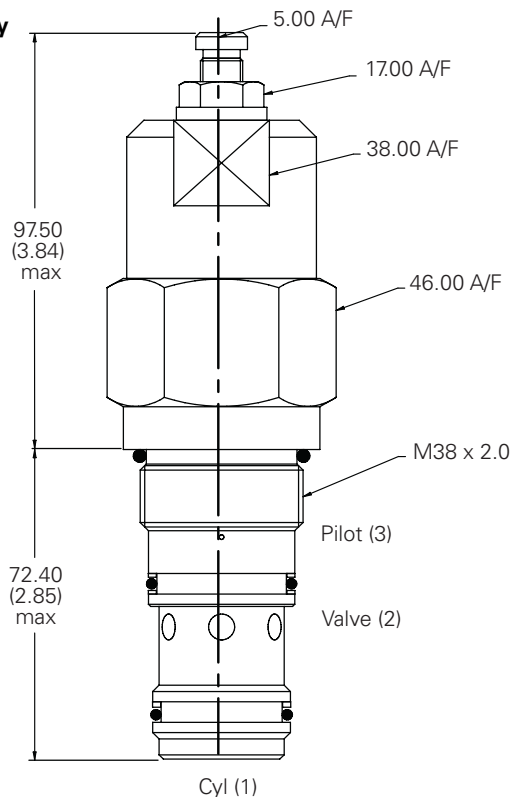

**Note:** For applications above 210 bar - please consult our technical department or use the steel body option

**Note:** Tightening torque of "F" adjuster locknut - 20 to 25 Nm.

### Single Valve

3/4", 1" Ports  
Basic Code 1CE145

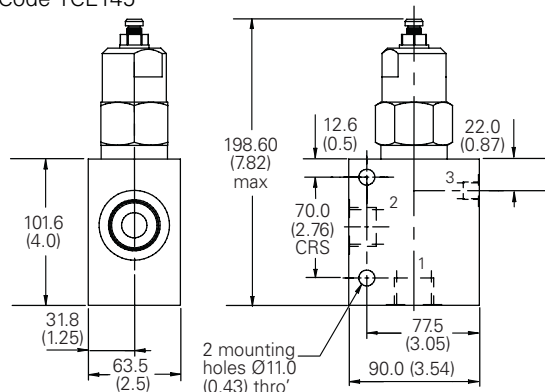

### Dual Valve

1" Ports  
Basic Code 1CEE145  
Internally Cross Piloted

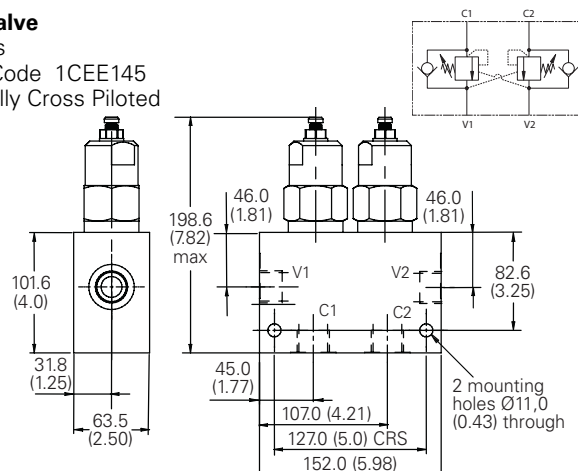

Where measurements are critical request certified drawings. We reserve the right to change specifications without notice.

# 1CER140 - Overcenter Valve

Part balanced, pilot assisted relief with check  
 140 L/min (37 USgpm) • 340 bar (4930 psi)

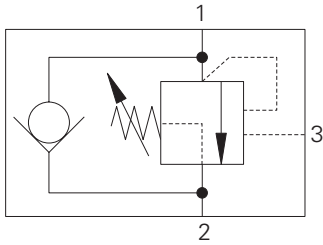

## Operation

The check section allows free flow into the actuator then holds and locks the load against movement. The pilot assisted relief valve section will give controlled movement when pilot pressure is applied. The relief section is normally set to open at a pressure at least 1.3 times the maximum load induced pressure but the pressure required to open the valve and allow movement

depends on the pilot ratio of the valve. For optimization of load control and energy usage, a choice of pilot ratios is available.

The pressure required to open the valve and start actuator movement can be calculated as follows:

$$\text{Pilot Pressure} = \frac{(\text{Relief Setting}) - (\text{Load Pressure})}{\text{Pilot Ratio}}$$

## Features

Cartridge is economical and fits simple cavity. Allows quick, easy field service - reduces down time. Interchangeable with pilot check valve of a similar size.

## Pilot Ratio

4:1 Best suited for applications where load varies and machine structure can induce instability.

6:1 Best suited for applications where the load remains relatively constant.

## Sectional View

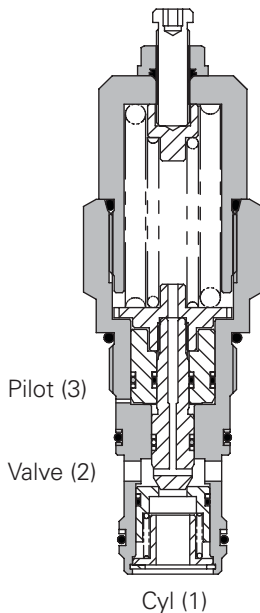

## Performance Data

### Ratings and Specifications

Figures based on: Oil Temp = 40°C Viscosity = 32 cSt (150 SUS)

Rated flow	140 L/min (37 USgpm)										
Max relief setting	420 bar (6090 psi)										
Max load induced pressure	340 bar (4930 psi)										
Cartridge material	Working parts hardened and ground steel. External surfaces zinc plated.										
Standard housing material	Aluminum (up to 210 bar). Add suffix "377" for steel option.										
Mounting position	Unrestricted										
Cavity number	A20081										
Torque cartridge into cavity	150 Nm (110 lbs ft)										
Weight	<table border="0"> <tr> <td>1CER140</td> <td>1.2 kg (2.6 lbs)</td> </tr> <tr> <td>1CER145 (aluminium)</td> <td>2.2 kg (4.8 lbs)</td> </tr> <tr> <td>1CER145 (steel)</td> <td>4.0 kg (8.8 lbs)</td> </tr> <tr> <td>1CEER145 (aluminium)</td> <td>2.9 kg (6.4 lbs)</td> </tr> <tr> <td>1CEER145 (steel)</td> <td>6.0 kg (13.2 lbs)</td> </tr> </table>	1CER140	1.2 kg (2.6 lbs)	1CER145 (aluminium)	2.2 kg (4.8 lbs)	1CER145 (steel)	4.0 kg (8.8 lbs)	1CEER145 (aluminium)	2.9 kg (6.4 lbs)	1CEER145 (steel)	6.0 kg (13.2 lbs)
1CER140	1.2 kg (2.6 lbs)										
1CER145 (aluminium)	2.2 kg (4.8 lbs)										
1CER145 (steel)	4.0 kg (8.8 lbs)										
1CEER145 (aluminium)	2.9 kg (6.4 lbs)										
1CEER145 (steel)	6.0 kg (13.2 lbs)										
Seal kit number	SK1108 (Nitrile) SK1108V (Viton®)										
Recommended filtration level	BS5540/4 Class 18/13 (25 micron nominal)										
Operating temperature	-30° to +90°C (-22° to +194°F)										
Leakage	0.3 milliliters/min nominal (5 dpm)										
Nominal viscosity range	5 to 500 cSt										

Viton is a registered trademark of E.I. DuPont

## Pressure Drop

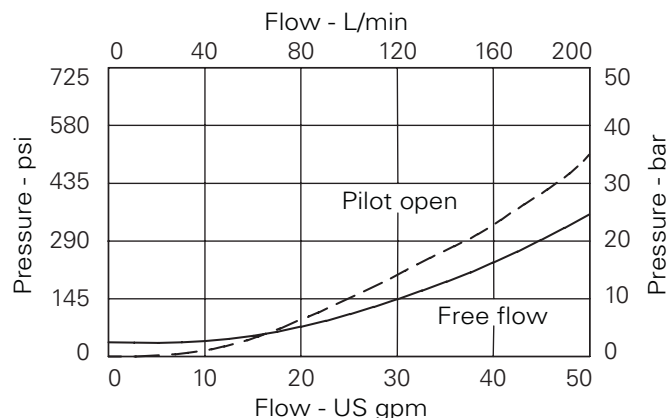

## Description

The 1CER series overcenter valve performs all duties of a regular overcenter but is able to relieve and stay open irrespective of downstream pressure. This enables the valve to operate when used with a closed center directional valve which has service line reliefs. The poppet is pressure balanced, preventing relief setting increase due to back pressure.

Where measurements are critical request certified drawings. We reserve the right to change specifications without notice.

# 1CER140 - Overcenter Valve

Part balanced, pilot assisted relief with check  
140 L/min (37 USgpm) • 340 bar (4930 psi)

## Model Code

**1CER\*\*\* - F 6W - 40 S 4**

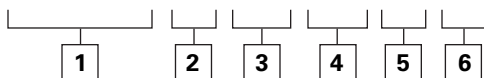

### 1 Function

**1CER140** - Cartridge Only  
**1CER145** - Cartridge and Body  
**1CEER145** - Cartridges and Body

### 2 Adjustment Means

**F** - Screw Adjustment

### 3 Port Sizes

Code	Port Size	Housing Number - Body Only			
		Aluminium Single	Steel Single	Aluminium Dual	Steel Dual
<b>6W</b>	3/4" BSP Valve & Cyl Port. 1/4" BSP Pilot Port	B20105	B20106		
<b>8W</b>	1" BSP Valve & Cyl Port. 1/4" BSP Pilot Port	B20107	B20108	C20285	C20287
<b>12T</b>	3/4" SAE Valve & Cyl Port. 1/4" SAE Pilot Port	B11952	B11953		
<b>16T</b>	1" SAE Valve & Cyl Port. 1/4" SAE Pilot Port	B11946	B11947	C30105	C30106

### 4 Pressure Range @ 4.8 l/min

**Note:** Code based on pressure in bar.

**20** - 140-250 bar.  
Std setting 190 bar  
**30** - 220-330 bar.  
Std setting 270 bar  
**40** - 310-420 bar.  
Std setting 370 bar  
Std setting made at 4.8 L/min

### 5 Seals

**S** - Nitrile (For use with most industrial hydraulic oils)  
**SV** - Viton (For high temperature and most special fluid applications)

### 6 Pilot Ratio

**4** - 4:1  
**6** - 6:1  
Other ratios available upon request

## Dimensions

mm (inch)

### Cartridge Only

Basic Code  
1CER140

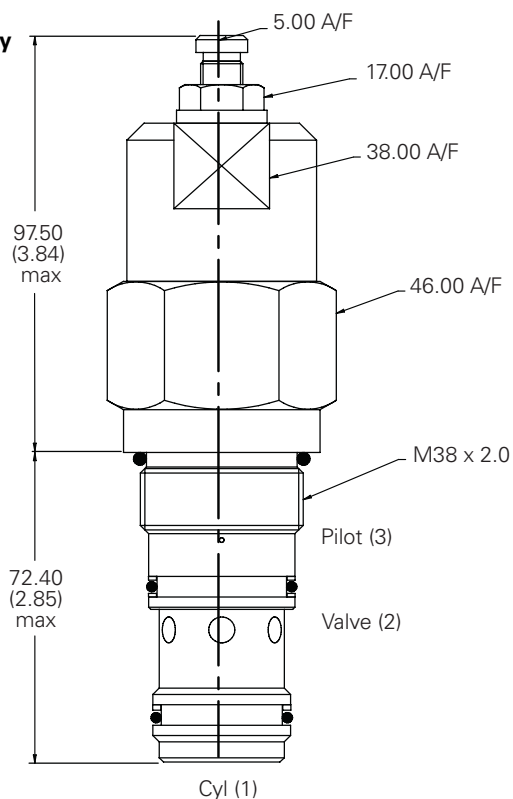

Cyl (1)

**Note:** For applications above 210 bar - please consult our technical department or use the steel body option

**Note:** Tightening torque of "F" adjuster locknut - 20 to 25 Nm.

### Single Valve

3/4", 1" Ports  
Basic Code  
1CER145

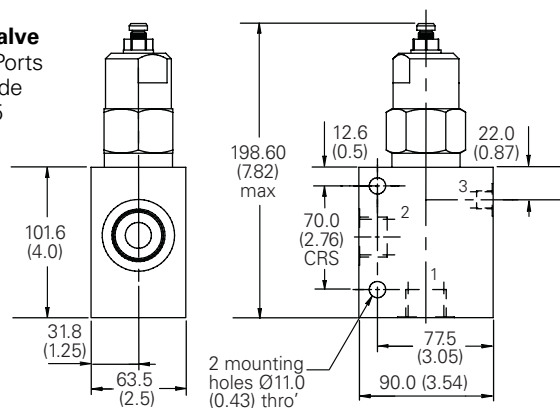

### Dual Valve

1" Ports  
Basic code 1CEER145  
Internally Cross Piloted

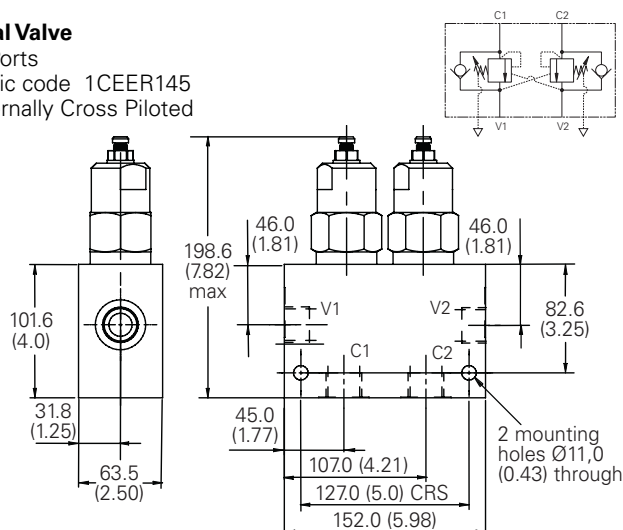

Where measurements are critical request certified drawings. We reserve the right to change specifications without notice.

# 1CEL140 - Overcenter Valve

Counterbalance, pilot assisted relief with check

140 L/min (37 USgpm) • 380 bar (5510 psi)

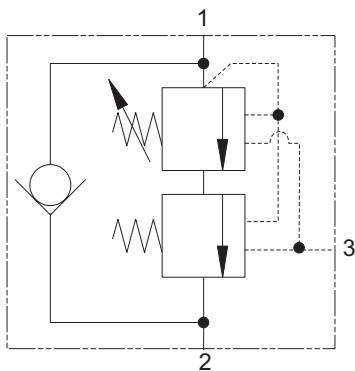

## Operation

The check section allows free flow and then locks the load against movement. The pilot assisted relief valve section will give controlled movement when pilot pressure is applied, maintaining a counterbalance pressure to prevent initial

pressure loss and therefore instability. The total pressure setting will normally be set at 1.3 times the load induced pressure. The counterbalance pressure reduces as the pilot pressure increases.

## Features

Cartridge is economical and fits simple cavity. Allows quick, easy field service - reduces down time. Interchangeable with pilot check valve of a similar size.

## Pilot Ratio

Primary 6.1:1

Secondary 0.5:1

## Performance Data

### Ratings and Specifications

Figures based on: Oil Temp = 40°C Viscosity = 32 cSt (150 SUS)

Rated flow	140 L/min (37 USgpm)	
Max setting	380 bar (5510 psi)	
Cartridge material	Working parts hardened and ground steel. External surfaces zinc plated.	
Standard housing material	Aluminum (up to 210 bar). Add suffix "377" for steel option.	
Mounting position	Unrestricted	
Cavity number	A20081	
Torque cartridge into cavity	150 Nm (110 lbs ft)	
Weight	1CEL140	1.2 kg (2.6 lbs)
	1CEL145 (aluminium)	2.2 kg (4.8 lbs)
	1CEL145 (steel)	4.0 kg (8.8 lbs)
	1CEEL145 (aluminium)	2.9 kg (6.4 lbs)
	1CEEL145 (steel)	6.0 kg (13.2 lbs)
Seal kit number	SK1108	(Nitrile)
	SK1108V	(Viton®)
Recommended filtration level	BS5540/4 Class 18/13 (25 micron nominal)	
Operating temperature	-30° to +90°C (-22° to +194°F)	
Leakage	0.3 milliliters/min nominal (5 dpm)	
Nominal viscosity range	5 to 500 cSt	

Viton is a registered trademark of E.I. DuPont

## Sectional View

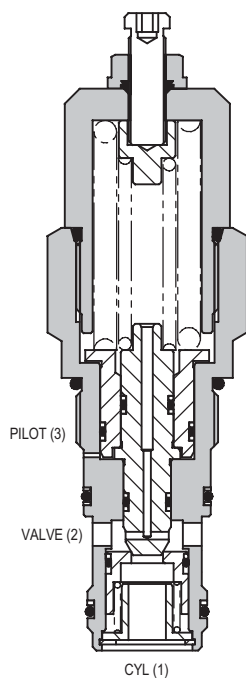

## Description

The 1CEL overcenter valve performs all duties of a regular overcenter but maintains a counterbalance pressure to provide dampening of cylinders when there is a rapid loss in stored pressure. This counterbalance pressure reduces as the pilot pressure increases. Typical applications include extension cylinders on telescopic handlers where it is important to have a smooth operation when retracting from full extension.

## Pressure Drop

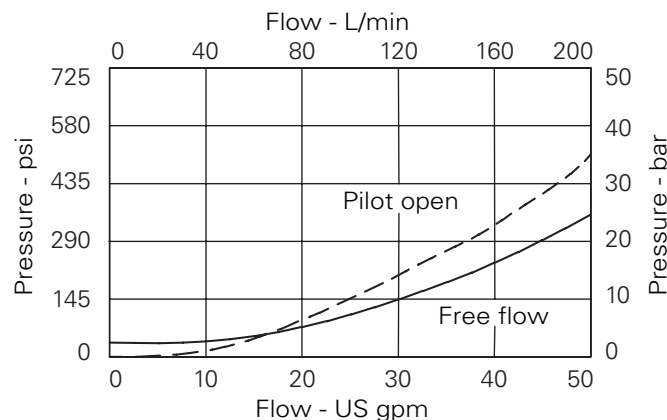

**Note:** This valve has been designed to eliminate instability from flexible boom applications or where the load induced pressure varies greatly. To get the best results, the settings should be adjusted for each application and then factory set for production quantities. Please contact Eaton/Integrated Hydraulics for more information.

Where measurements are critical request certified drawings. We reserve the right to change specifications without notice.

# 1CEL140 - Overcenter Valve

Counterbalance, pilot assisted relief with check  
 140 L/min (37 USgpm) • 380 bar (5510 psi)

## Model Code

**1CEL\*\*\* - F 6W - 30 S 220 / 60**

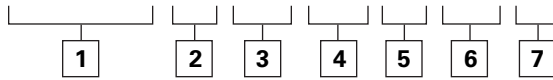

### 1 Function

- 1CEL140** - Cartridge Only
- 1CEL145** - Cartridge and Body
- 1CEEL145** - Cartridges and Body

### 2 Adjustment Means Counterbalance Setting

F - Screw Adjustment

### 3 Port Sizes

Code	Port Size	Housing Number - Body Only			
		Aluminium Single	Steel Single	Aluminium Dual	Steel Dual
6W	3/4" BSP Valve & Cyl Port. 1/4" BSP Pilot Port	B20105	B20106		
8W	1" BSP Valve & Cyl Port. 1/4" BSP Pilot Port	B20107	B20108	C20285	C20287
16T	1" SAE Valve & Cyl Port. 1/4" SAE Pilot Port	B11946	B11947	C30105	C30106

### 4 Pressure Range @ 4.8 l/min

**Note:** Code based on pressure in bar.

- 20** - 170-320. Std 220 (160/60)
- 30** - 230-380. Std 280 (220/60)
- 40** - 310-380. Std 350 (290/60)

### 5 Seals

- S** - Nitrile (For use with most industrial hydraulic oils)
- SV** - Viton (For high temperature and most special fluid applications)

### 7 High Pressure Setting Bar

(10 bar increments).  
 150 to 350 bar (2175 to 5000 psi)

### 6 Counterbalance Setting Bar

(10 bar increments).  
 20 to 100 bar (300 to 1500 psi)

## Dimensions

mm (inch)

### Cartridge Only

Basic Code  
 1CEL140

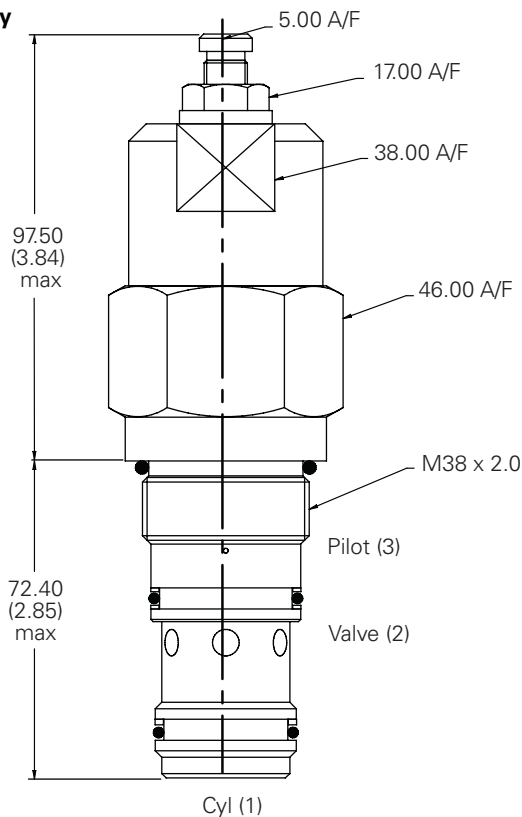

**Note:** For applications above 210 bar - please consult our technical department or use the steel body option.

**Note:** Tightening torque of "F" adjuster locknut - 20 to 25 Nm.

### Single Valve

3/4", 1" Ports  
 Basic Code  
 1CEL145

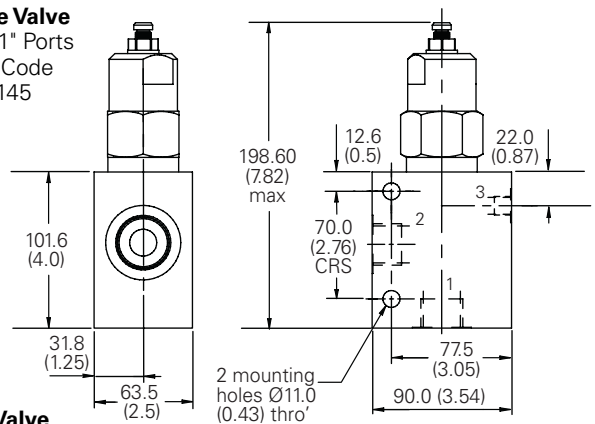

### Dual Valve

1" Ports  
 Basic code 1CEEL145  
 Internally Cross Piloted

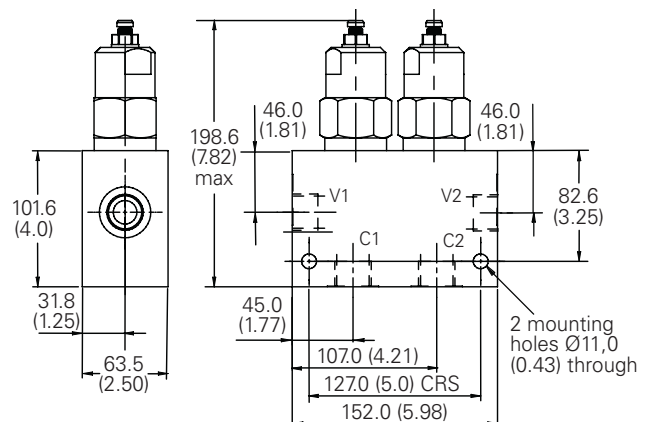

Where measurements are critical request certified drawings. We reserve the right to change specifications without notice.

# ICE300 - Overcenter Valve

Pilot assisted relief with check

300 L/min (80 USgpm) • 270 bar (4000 psi)

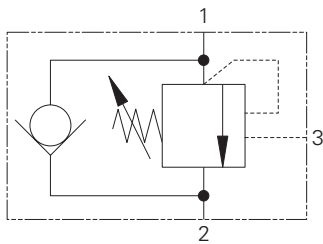

## Operation

The check section allows free flow into the actuator then holds and locks the load against movement. The pilot assisted relief valve section will give controlled movement when pilot pressure is applied. The relief section is normally set to open at a pressure at least 1.3 times the maximum load induced pressure but the pressure required to open the

valve and allow movement depends on the pilot ratio of the valve. For optimization of load control and energy usage, a choice of pilot ratios is available.

The pressure required to open the valve and start actuator movement can be calculated as follows:

$$\text{Pilot Pressure} = \frac{(\text{Relief Setting}) - (\text{Load Pressure})}{\text{Pilot Ratio}}$$

## Features

Cartridge is economical and fits simple cavity. Allows quick, easy field service - reduces down time. Interchangeable with pilot check valve of a similar size.

## Pilot Ratio

3:1 Best suited for applications where load varies and machine structure can induce instability.

8:1 Best suited for applications where the load remains relatively constant.

## Sectional View

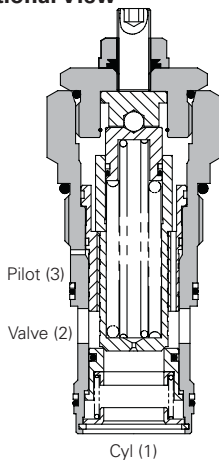

F

## Description

Overcenter valves give static and dynamic control of loads by regulating the flow into and out of hydraulic actuators. When installed close to or within an actuator, the overcenter valve will stop runaway in the event of hose burst and if open center directional control valves are used, will allow thermal expansion relief of the hydraulic fluid.

The overcenter cartridge is ideal for mounting directly into a cavity machined in the body of the cylinder, motor or rotary actuator. The cartridge can also be mounted directly to the ports via a specifically machined body as part of a Hydraulic Integrated Circuit or single unit, or contained within one of our standard line bodies.

Single overcenter valves are normally used when the load is unidirectional, for example an aerial platform or crane and dual overcenter valves are used for controlling loads in both directional for motor applications or for cylinders going over center.

## Performance Data

### Ratings and Specifications

Figures based on: Oil Temp = 40°C Viscosity = 32 cSt (150 SUS)

Rated flow	300 L/min (80 USgpm)
Max relief pressure	350 bar (5000 psi)
Max load induced pressure	270 bar (4000 psi)
Cartridge material	Working parts hardened and ground steel. External surfaces zinc plated.
Standard housing material	Aluminium (up to 210 bar). Add suffix "377" for steel option.
Mounting position	Unrestricted
Cavity	A6935 (See Section M)
Torque cartridge into cavity	150 Nm (110 lbs ft)
Weight cartridge only	1CE300 0.91 kg ( 2.00 lbs) 1CE350 2.71 kg ( 5.96 lbs) 1CEE350 5.42 kg (11.92 lbs)
Seal kit	SK437 (Nitrile) SK437V (Viton®)
Filtration	BS5540/4 Class 18/13 (25 micron nominal)
Temperature range	-30°C to +90°C (-22° to +194°F)
Internal leakage	4 milliliters/min nominal (60 dpm)
Nominal viscosity range	5 to 500 cSt

Viton is a registered trademark of E.I. DuPont

## Pressure Drop

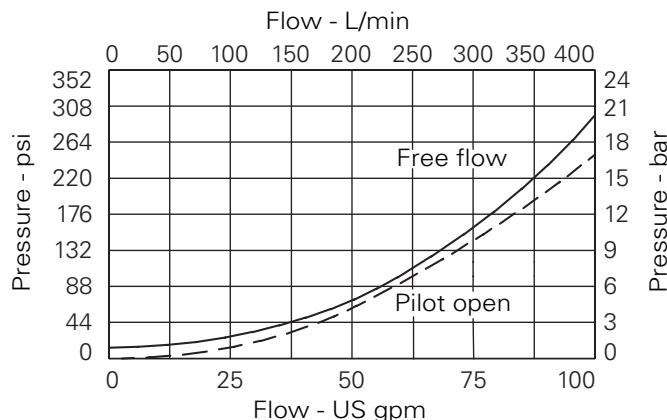

Where measurements are critical request certified drawings. We reserve the right to change specifications without notice.

# ICE300 - Overcenter Valve

Pilot assisted relief with check

300 L/min (80 USgpm) • 270 bar (4000 psi)

## Model Code

**1CE\*\*\*\* - F      10W - 35      S      3**

1    2    3    4    5    6

### 1 Function

**1CE300** - Cartridge only  
**1CE350** - Cartridge and Body  
**1CEE350** - Cartridges and Body

### 2 Adjustment

F - Screw adjustment

### 3 Port Size

Code	Port Size	Housing Number - Body Only			
		Aluminium Single	Steel Single	Aluminium Dual	Steel Dual
<b>10W</b>	1 1/4" BSP Valve & Cyl Port 1/4" BSP Pilot Port	B6814	B8610	C8704	C8705
<b>20T</b>	1 1/4" SAE Valve & Cyl Port 1/4" SAE Pilot Port	B10630	B11474	C10811	C11564

### 4 Pressure Range

**Note:** Code based on pressure in bar.  
**35** - 70-350 bar.  
 Std setting 210 bar.  
 Std setting made at 4.8 L/min

### 5 Seal Material

**S** - Buna-N  
**SV** - Viton

### 6 Pilot Ratio

**3** - 3:1 - (Standard)  
**8** - 8:1

## Dimensions

mm (inch)

### Cartridge Only

Basic Code  
 1CE300

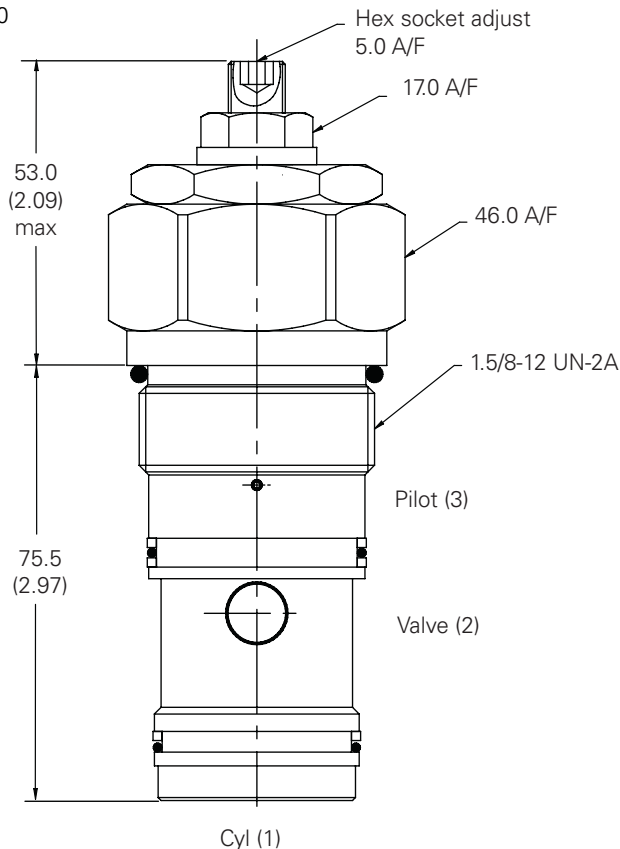

**Note:** For applications above 210 bar - please consult our technical department or use the steel body option.

**Note:** Tightening torque of "F" adjuster locknut - 20 to 25 Nm.

### Single Valve

1 1/4" Ports  
 Basic Code  
 1CE350

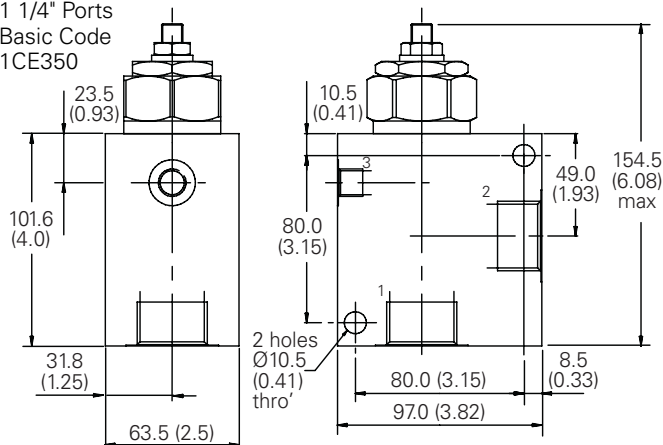

### Dual Valve

1 1/4" Ports  
 Basic code 1CEE350  
 Internally Cross Piloted

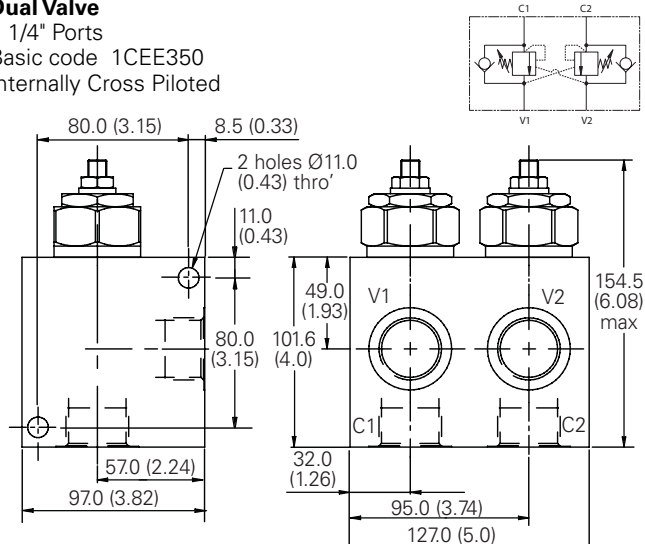

Where measurements are critical request certified drawings. We reserve the right to change specifications without notice.

# ICEB300 - Overcenter Valve

Fully balanced, pilot assisted

300 L/min (80 USgpm) • 270 bar (4000 psi)

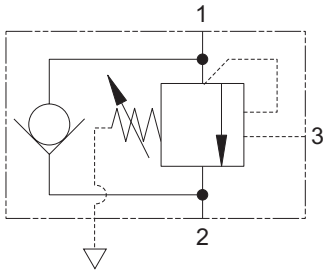

## Sectional View

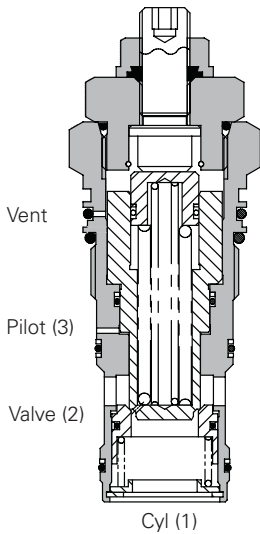

## Description

Overcenter valves give static and dynamic control of loads by supplying a counterbalance pressure to the actuator. They prevent runaway in the event of hose burst and hold the load with minimal leakage.

The pressure balanced valve is unaffected by back pressure, allowing service line reliefs to operate and for the valve to be used in regenerative or proportional valve systems.

The overcenter valve should be mounted either into, onto or as close to the actuator as possible to give maximum protection.

Single overcenter valves control unidirectional loads such as in aerial platforms, cranes or winches and dual overcenters are suited to bi-directional motion such as wheel motor applications or cylinders going over center.

## Operation

The check section allows free flow into the actuator then holds and locks the load against movement. The pilot assisted relief valve section will give controlled movement when pilot pressure is applied. The relief section is normally set to open at a pressure at least 1.3 times the maximum load induced pressure but the pressure required to open the valve and

allow movement depends on the pilot ratio of the valve. For optimization of load control and energy usage, a choice of pilot ratios is available.

The pressure required to open the valve and start actuator movement can be calculated as follows:

$$\text{Pilot Pressure} = \frac{(\text{Relief Setting}) - (\text{Load Pressure})}{\text{Pilot Ratio}}$$

## Features

Cartridge is economical and fits simple cavity. Allows quick, easy field service - reduces down time. Interchangeable with pilot check valve of a similar size.

## Pilot Ratio

3:1 Best suited for applications where load varies and machine structure can induce instability.

8:1 Best suited for applications where the load remains relatively constant.

## Performance Data

### Ratings and Specifications

Figures based on: Oil Temp = 40°C Viscosity = 32 cSt (150 SUS)

Rated flow	300 L/min (80 USgpm)
Max working pressure	350 bar (5000 psi)
Max load induced pressure	270 bar (4000 psi)
Cartridge material	Working parts hardened and ground steel. External surfaces zinc plated.
Standard housing material	Aluminium (up to 210 bar) Add suffix "377" for steel option
Mounting position	Unrestricted
Cavity	A6935 (See Section M)
Torque cartridge into cavity	150 Nm (110 lbs ft)
Weight cartridge only	1CE300 0.91 kg (2.00 lbs) 1CE350 2.71 kg (5.96 lbs) 1CEE350 5.42 kg (11.92 lbs)
Seal kit	SK686 (Nitrile) SK686V (Viton®)
Filtration	BS5540/4 Class 18/13 (25 micron nominal)
Temperature range	-30°C to +90°C (-22° to +194°F)
Internal leakage	4 milliliters/min nominal (60 dpm)
Nominal viscosity range	5 to 500 cSt

Viton is a registered trademark of E.I. DuPont

## Pressure Drop

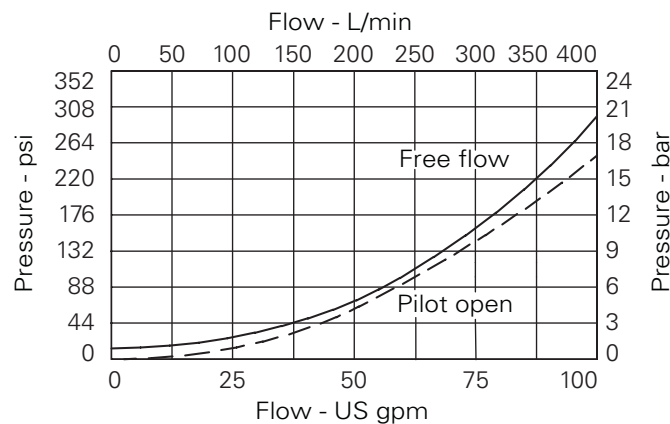

Where measurements are critical request certified drawings. We reserve the right to change specifications without notice.

# ICEB300 - Overcenter Valve

Fully balanced, pilot assisted

300 L/min (80 USgpm) • 270 bar (4000 psi)

Model Code

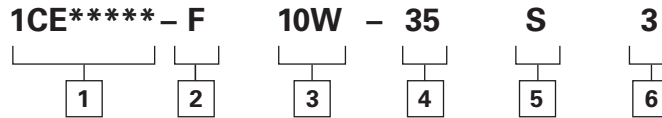

## 1 Basic Code

**1CEB300** - Cartridge only

**1CEB350** - Cartridge and Body

**1CEE350** - Cartridges and Body

## 2 Adjustment Means

**F** - Screw adjustment

## 3 Port Sizes

Code	Port Size	Housing Number - Body Only			
		Aluminium Single	Steel Single	Aluminium Dual	Steel Dual
<b>10W</b>	1 1/4" BSP Valve & Cyl Port 1/4" BSP Pilot Port	B6814	B8610	C8704	C8705
<b>20T</b>	1 1/4" SAE Valve & Cyl Port 1/4" SAE Pilot Port	B10630	B11474	C10811	C11564

## 4 Pressure Range @ 4.8 L/min

**Note:** Code based on pressure in bar.

**35** - 70-350 bar.  
Std setting 210 bar

Std setting made at 4.8 L/min

## 5 Seals

**S** - Nitrile (For use with most industrial hydraulic oils)

**SV** - Viton (For high temperature and most special fluid applications)

## 6 Pilot Ratio

**3** - 3:1 - (Standard)

**8** - 8:1

## Dimensions

mm (inch)

### Cartridge Only

Basic Code

1CEB300

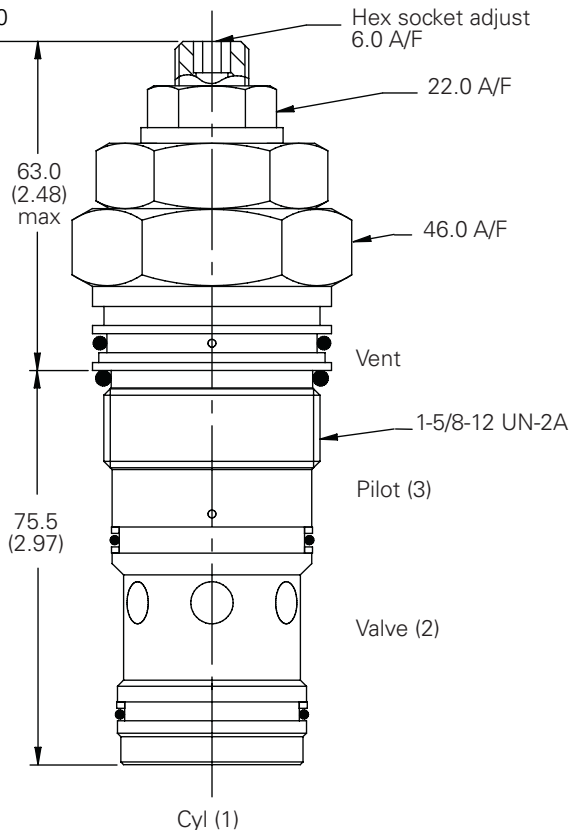

**Note:** Tightening torque of "F" adjuster locknut - 20 to 25 Nm.

**Note:** For applications above 210 bar - please consult our technical department or use the steel body option.

### Single Valve

1 1/4" Ports

Basic Code

1CEB350

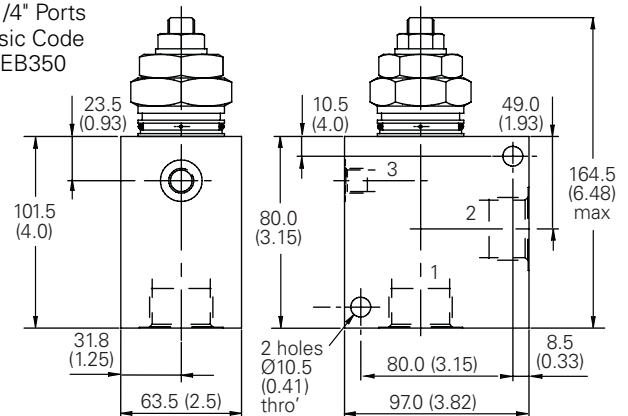

### Dual Valve

1 1/4" Ports

Basic Code 1CEE350

Internally Cross Piloted

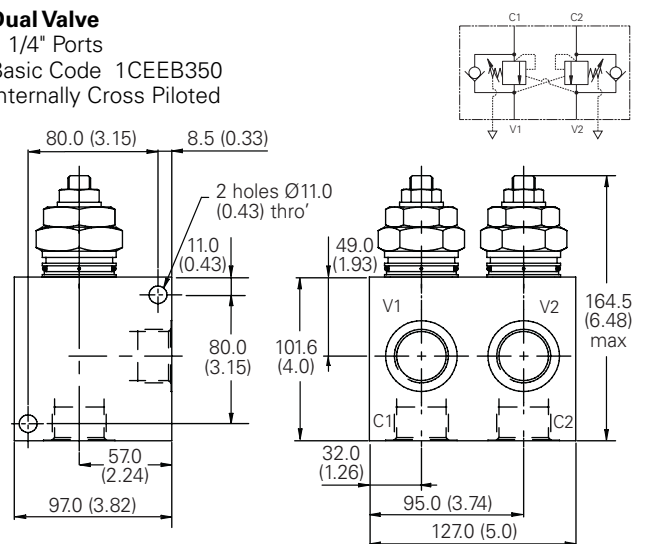

Where measurements are critical request certified drawings. We reserve the right to change specifications without notice.

# ICEBD300 - Overcenter Valve

Fully balanced, pilot assisted relief with check  
300 L/min (80 USgpm) • 270 bar (4000 psi)

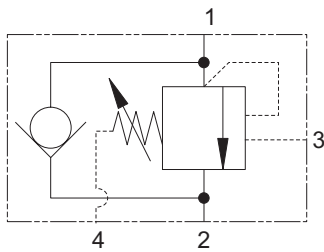

Sectional View

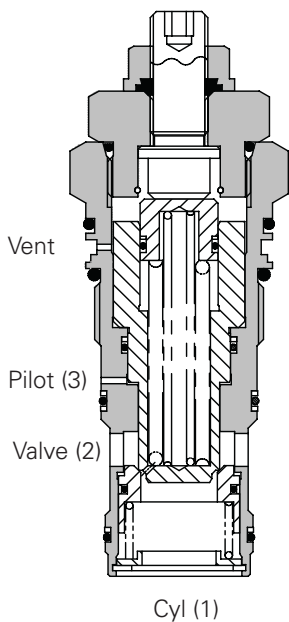

## Operation

"The check section allows free flow into the actuator then holds and locks the load against movement. The pilot assisted relief valve section will give controlled movement when pilot pressure is applied. The relief section is normally set to open at a pressure at least 1.3 times the maximum load induced pressure but the pressure required to open the valve and

allow movement depends on the pilot ratio of the valve. For optimization of load control and energy usage, a choice of pilot ratios is available.

The pressure required to open the valve and start actuator movement can be calculated as follows:

$$\text{Pilot Pressure} = \frac{(\text{Relief Setting}) - (\text{Load Pressure})}{\text{Pilot Ratio}}$$

## Features

Cartridge is economical and fits simple cavity. Allows quick, easy field service - reduces down time.

## Pilot Ratio

3:1 Best suited for applications where load varies and machine structure can induce instability.

8:1 Best suited for applications where the load remains relatively constant.

## Performance Data

### Ratings and Specifications

Figures based on: Oil Temp = 40°C Viscosity = 32 cSt (150 SUS)

Rated flow	300 L/min (80 USgpm)
Max relief pressure	350 bar (5000 psi)
Max load induced pressure	270 bar (4000 psi)
Cartridge material	Working parts hardened and ground steel. External surfaces zinc plated.
Mounting position	Unrestricted
Cavity	A13098 (See Section M)
Torque cartridge into cavity	150 Nm (110 lbs ft)
Weight cartridge only	0.91 kg (2.00 lbs)
Seal kit	SK686 (Nitrile) SK686V (Viton®) SK686P (Polyurethane Nitrile)
Filtration	BS5540/4 Class 18/13 (25 micron nominal)
Temperature range	-30° to +90°C (-22° to +194°F)
Internal leakage	4 milliliters/min (60 dpm)
Nominal viscosity range	5 to 500 cSt

Viton is a registered trademark of E.I. DuPont

## Pressure Drop

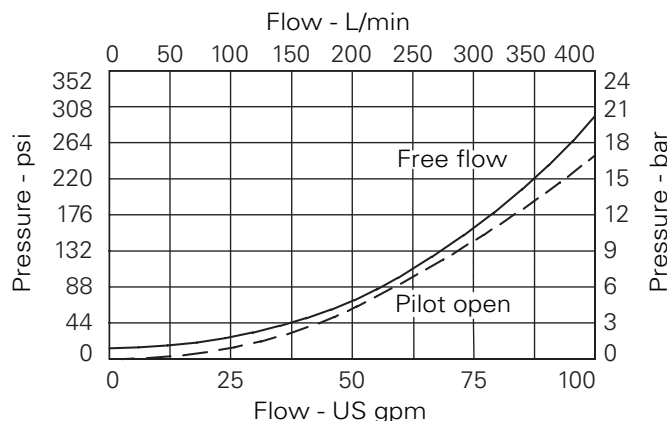

## Description

Overcenter valves give static and dynamic control of loads by supplying a counterbalance pressure to the actuator. They prevent runaway in the event of hose burst and hold the load with minimal leakage.

The pressure balanced valve is unaffected by back pressure, allowing service line reliefs to operate and for the valve to be used in regenerative or proportional valve systems.

The overcenter valve should be mounted either into, onto or as close to the actuator as possible to give maximum protection.

Single overcenter valves control unidirectional loads such as in aerial platforms, cranes or winches and dual overcenters are suited to bi-directional motion such as wheel motor applications or cylinders going over center.

Where measurements are critical request certified drawings. We reserve the right to change specifications without notice.

# 1CEBD300 - Overcenter Valve

Fully balanced, pilot assisted relief with check  
 300 L/min (80 USgpm) • 270 bar (4000 psi)

## Model Code

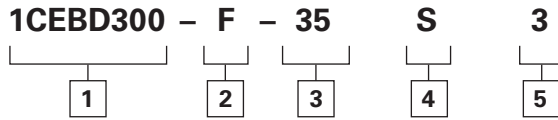

### 1 Basic Code

**1CEBD300** - Cartridge only

### 2 Adjustment

**F** - Screw adjustment

### 3 Pressure Range @4.8 L/min

**Note:** Code based on pressure in bar.

**35** - 70-350 bar.  
 Std setting 210 bar  
 Std setting made at 4.8 L/min

### 4 Seals

**S** - Nitrile (For use with most industrial hydraulic oils)  
**SV** - Viton (For high temperature and most special fluid applications)  
**P** - Polyurethane/Nitrile (For arduous applications)

### 5 Pilot Ratio

**3** - 3:1 - (Standard)  
**8** - 8:1

## Dimensions

mm (inch)

### Cartridge Only

Basic Code  
 1CEBD300

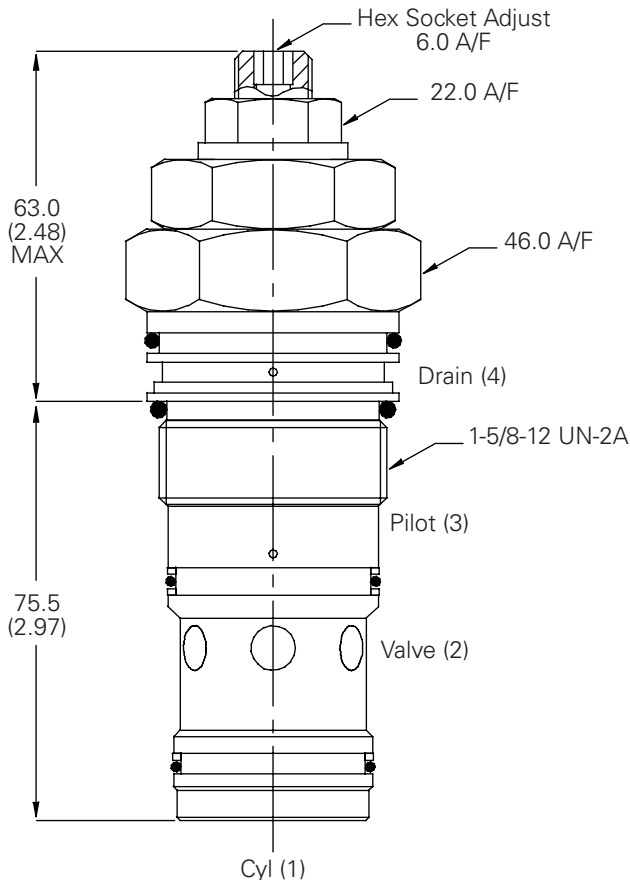

**Note:** Tightening torque of "F" adjuster locknut - 20 to 25 Nm.

Where measurements are critical request certified drawings. We reserve the right to change specifications without notice.



# ICPPD300 - Piloted Bi-directional Poppet Valve

Poppet, pilot operated, normally closed, zero differential  
300 L/min (80 USgpm) • 350 bar (5000 psi)

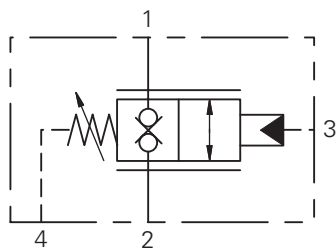

Sectional View

## Operation

By the application of pilot pressure to the pilot port the poppet moves back against the main spring opening. The metering characteristic of the valve is controlled by the rate of the spring, the seat angle and the pilot pressure applied.

Due to the balanced poppet design load induced pressure will not open the valve and once open valve port pressure will not increase the pilot pressure required to keep the valve open.

## Features

The cartridge fits a simple cavity allowing quick, easy field service reducing down time. Hardened poppet and seat provide for long leak free performance.

## Performance Data

### Ratings and Specifications

Figures based on: Oil Temp = 40°C Viscosity = 32 cSt (150 SUS)

Rated flow	300 L/min (80 USgpm)
Max working pressure	350 bar (5000 psi)
Cartridge material	Working parts hardened and ground steel. External surfaces Nickel/Zinc plated.
Mounting position	Unrestricted
Cavity	A13098 (See Section M)
Torque cartridge into cavity	150 Nm (110 lbs ft)
Weight cartridge only	1.02 kg (2.25 lbs)
Seal kit	SK1454 (Nitrile) SK1454V (Viton®) SK1454P (Polyurethane/Nitrile)
Filtration	BS5540/4 Class 18/13 (25 micron nominal)
Temperature range	-30° to +90°C (-22° to +194°F)
Internal leakage	4 milliliters/min nominal (60 dpm)
Nominal viscosity range	5 to 500 cSt

Viton is a registered trademark of E.I. DuPont

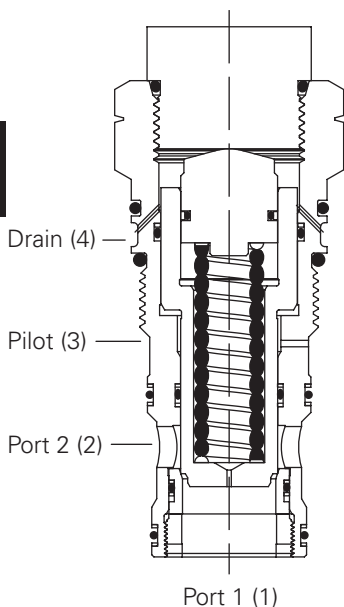

F

## Description

Normally closed pilot operated zero differential bi-directional poppet valve providing flow control by application of pilot pressure to actuate the poppet and increase the flow path.

Balanced construction ensures predictable switching regardless of pressure in port 1 or 2. The drain line allows the valve to be used in corrosive atmospheres preventing the ingress of atmospheric contamination.

## Pilot open pressure drop - both directions

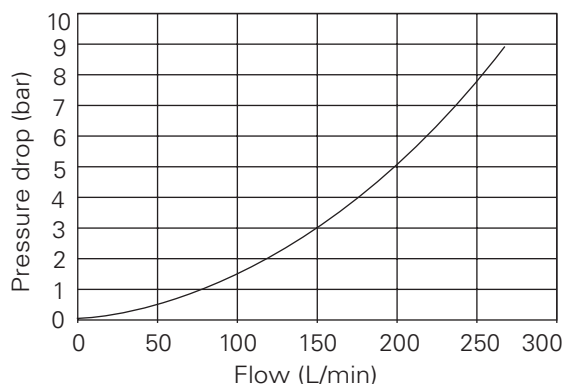

Where measurements are critical request certified drawings. We reserve the right to change specifications without notice.

# ICPPD300 - Piloted Bi-directional Poppet Valve

Poppet, pilot operated, normally closed, zero differential  
 300 L/min (80 USgpm) • 350 bar (5000 psi)

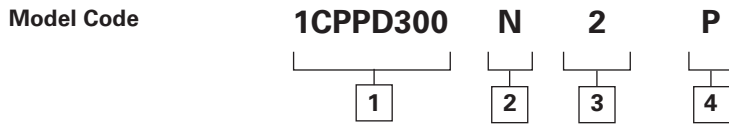

**1 Function**  
**1CPPD300** - Cartridge only

**2 Adjustment**  
**N** - Fixed - State pressure setting required

**3 Pilot Pressure**  
**Note:** Code based on pressure in bar.  
**2** - 14 bar.  
 Std setting made at 4.8 L/min

**4 Seal Material**

- S** - Nitrile (For use with most industrial hydraulic oils)
- SV** - Viton® (For high temperature and most special fluid applications)
- P** - Polyurethane/Nitrile (For arduous applications)

**Dimensions**  
 mm (inch)

**Cartridge Only**  
 Basic Code  
 1CPPD300

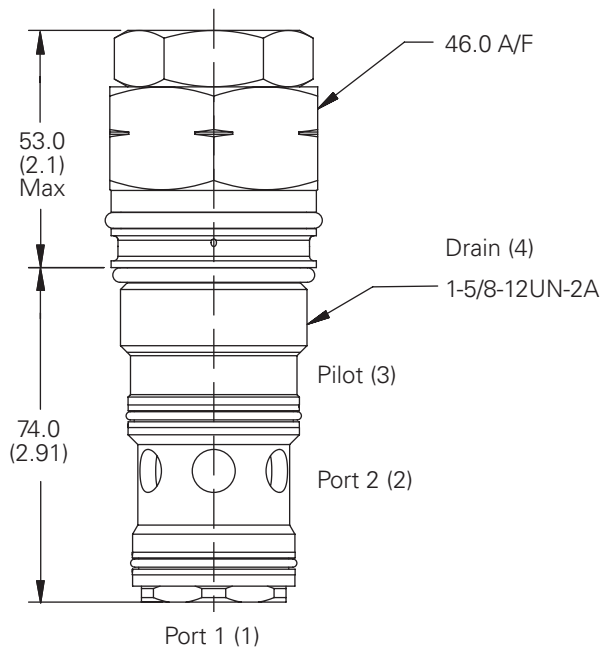

Where measurements are critical request certified drawings. We reserve the right to change specifications without notice.

# ICE356 Series - Overcenter Valve

Alternative body arrangements for 300 L/min valves

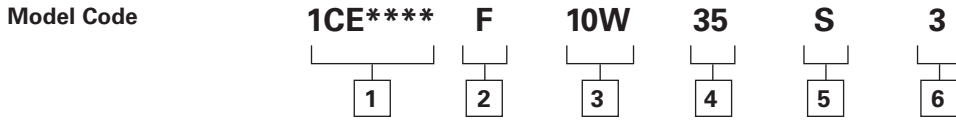

**1 Function**  
**1CE356** - Cartridge and Body Through Ported  
**1CEG350** - Cartridge and Body Gasket Mounted

**2 Adjustment**  
 F - Screw adjustment

**3 Port Size - Bodied Valves Only**

Code	Port Size	Housing Number	
1CE356 Through Ported, Body Only		Aluminium	Steel
<b>10W</b>	1 1/4" BSP Valve & Cyl Port 1/4" BSP Pilot Port	C13637	C13638
1CEG356 Gasket Mounted, Sub Assembly			
<b>10W</b>	1 1/4" BSP Valve & Cyl Port 1/4" BSP Pilot Port	CXP20647-10W-S	CXP20647-10W-S-377

**4 Pressure Range**  
**Note:** Code based on pressure in bar.  
**35** - 70-350 bar.  
           Std setting 210 bar  
           (10:1): 100-210 bar  
           Std setting made at 4.8 L/min

**5 Seal Material**  
**S** - Buna-N  
**SV** - Viton

**6 Pilot Ratio**  
**3** - 3:1 - (Standard)  
**8** - 8:1

## Dimensions

mm (inch)

**Complete Valve - Through Ported**  
 1 1/4" Ports  
 Basic Code  
 1CE356

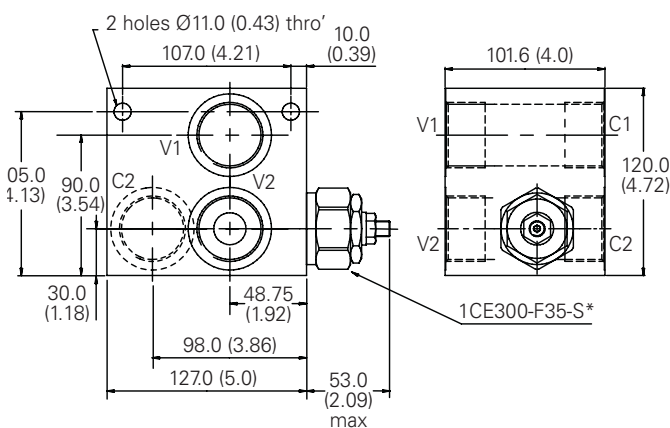

**Complete Valve - Gasket Mounted**  
 1 1/4" Ports  
 Basic Code  
 1CEG350

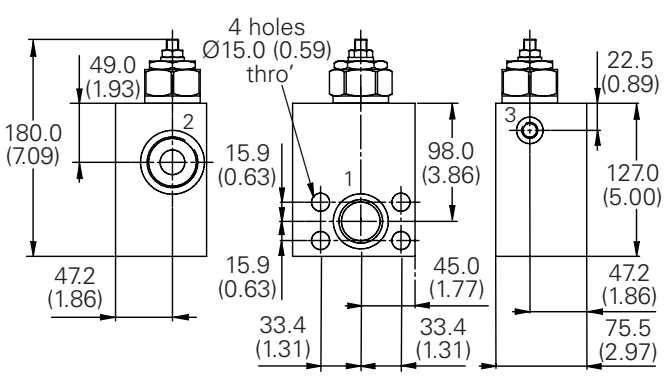

**Note:** For applications above 210 bar - please consult our technical department or use the steel body option.

**Note:** Tightening torque of "F" adjuster locknut - 20 to 25 Nm.

Where measurements are critical request certified drawings. We reserve the right to change specifications without notice.

# For wind energy, it's... Reliability.

Together with our customers, we are working to sustain and safeguard the environment, everywhere our products are at work.



F

**EATON**  
*Powering Business Worldwide*

## Durability. Reliability. Sustainability.

Eaton's integrated systems help harvest the inexhaustible green power of wind. In constant use under the harshest conditions, wind turbines demand extreme reliability and durability from every component. Eaton is a world leading manufacturer of those critical hydraulic, electrical and filtration products.

©2008 Eaton Corporation

# ISE30 - Overcenter Valve

Pilot assisted relief with check

30 L/min (8 USgpm) • 270 bar (4000 psi)

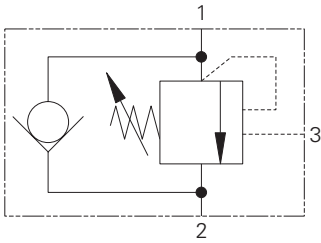

Sectional View

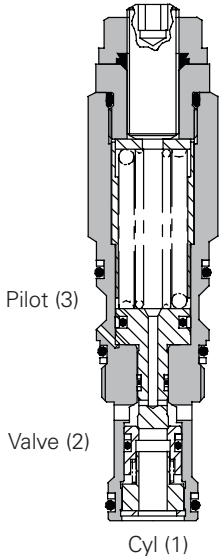

## Operation

The check section allows free flow into the actuator then holds and locks the load against movement. The pilot assisted relief valve section will give controlled movement when pilot pressure is applied. The relief section is normally set to open at a pressure at least 1.3 times the maximum load induced pressure but the pressure required to open the valve and allow movement

depends on the pilot ratio of the valve. For optimization of load control and energy usage, a choice of pilot ratios is available.

The pressure required to open the valve and start actuator movement can be calculated as follows:

$$\text{Pilot Pressure} = \frac{(\text{Relief Setting}) - (\text{Load Pressure})}{\text{Pilot Ratio}}$$

## Features

Cartridge is economical and fits simple cavity. Allows quick, easy field service - reduces down time. Interchangeable with pilot check valve of a similar size.

## Pilot Ratio

2.5:1 Best suited for extremely unstable applications such as long booms or flexible frameworks.

5:1 (standard) Best suited for applications where load varies and machine structure can induce instability.

10:1 Best suited for applications where the load remains relatively constant.

## Performance Data

### Ratings and Specifications

Figures based on: Oil Temp = 40°C Viscosity = 32 cSt (150 SUS)

Rated flow	30 L/min (8 USgpm)
Max relief setting	350 bar (5000 psi)
Max load induced pressure	270 bar (4000 psi)
Cartridge material	Working parts hardened and ground steel. External steel surfaces zinc plated.
Mounting position	Unrestricted
Cavity number	A20090-T11A
Torque cartridge into cavity	45 Nm (33 lbs ft)
Weight	0.15 kg (0.33 lbs)
Seal kit number	SK1079 (Nitrile) SK1079V (Viton®)
Recommended filtration level	BS5540/4 Class 18/13 (25 micron nominal)
Operating temperature	-30° to +90°C (-22° to +194°F)
Leakage	0.3 milliliters/min nominal (5 dpm)
Nominal viscosity range	5 to 500 cSt

## Description

Overcenter valves give static and dynamic control of loads by regulating the flow into and out of hydraulic actuators. When installed close to or within an actuator, the overcenter valve will stop runaway in the event of hose burst and if open center directional control valves are used, will allow thermal expansion relief of the hydraulic fluid.

The overcenter cartridge is ideal for mounting directly into a cavity machined in the body of the cylinder, motor or rotary actuator. The cartridge can also be mounted directly to the ports via a specifically machined body as part of a Hydraulic Integrated Circuit or single unit, or contained within one of our standard line bodies.

Single overcenter valves are normally used when the load is unidirectional, for example an aerial platform or crane and dual overcenter valves are used for controlling loads in both directional for motor applications or for cylinders going over center.

Where measurements are critical request certified drawings. We reserve the right to change specifications without notice.

## Pressure Drop

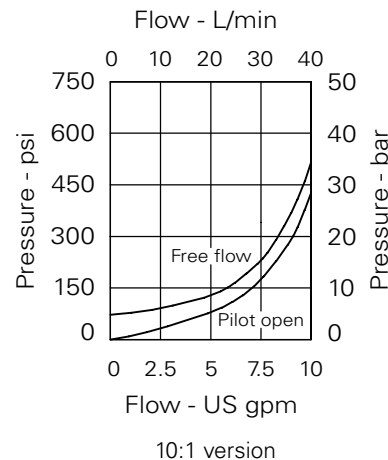
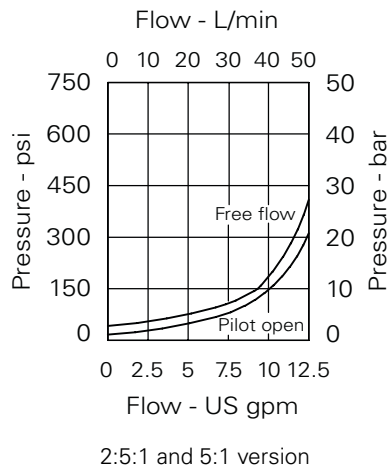

# ISE30 - Overcenter Valve

Pilot assisted relief with check  
30 L/min (8 USgpm) • 270 bar (4000 psi)

Model Code

**1SE30 - F - 35 S 5**

1   
 2   
 3   
 4   
 5

## 1 Function

**1SE30**

## 2 Adjustment Means

**F** - Screw Adjustment  
**N** - Fixed - State pressure setting required

For fixed versions add setting in 10 bar increments to end of part number. Subject to a ±10% tolerance.

## 3 Pressure Range

**Note:** Code based on pressure in bar.

**20** - (All pilot ratios):  
70-225 bar.  
Std setting 100 bar

**35** - (2.5:1 and 5:1): 70-350 bar.  
Std setting 210 bar  
(10:1): 90-350 bar.  
Std setting 210 bar

Std setting made at 4.8 L/min  
Other pressure ranges available on request

## 4 Seals

**S** - Nitrile  
(For use with most industrial hydraulic oils)

**SV** - Viton  
(For high temperature and most special fluid applications)

## 5 Pilot Ratio

**2** - 2.5:1  
**5** - 5:1  
**10** - 10:1

## Dimensions

mm (inch)

### Cartridge Only

Basic Code  
1SE30

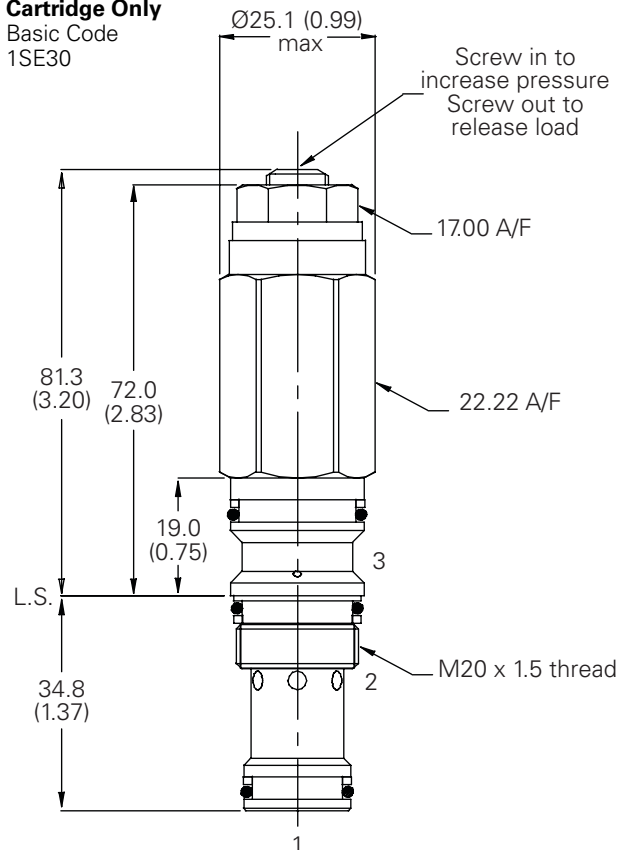

### Cavity

Model A20090-T11A  
Form Drill TD-11A  
Form Reamer TD-11A

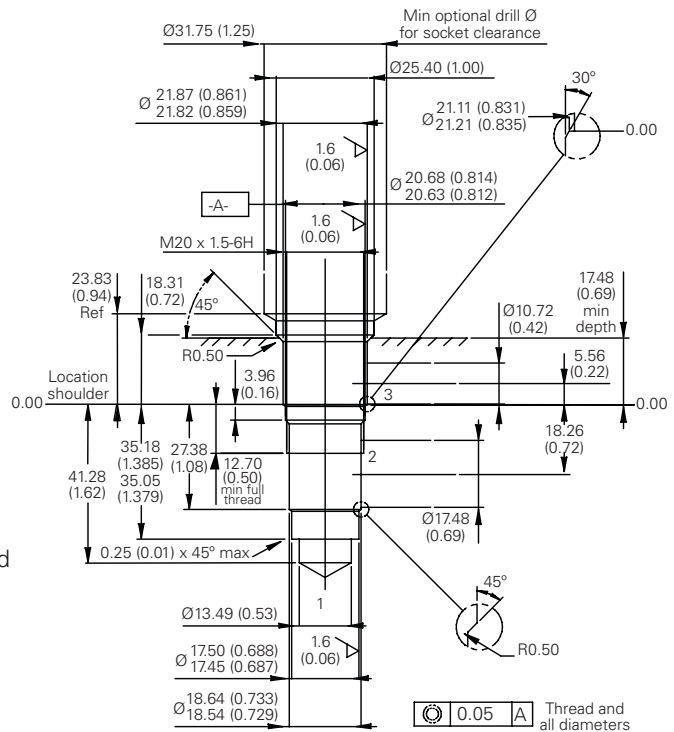

**Note:** Tightening torque of "F" adjuster locknut - 20 to 25 Nm.

Where measurements are critical request certified drawings. We reserve the right to change specifications without notice.

# 1SER30 - Overcenter Valve

Part balanced, pilot assisted relief with check  
30 L/min (8 USgpm) • 270 bar (4000 psi)

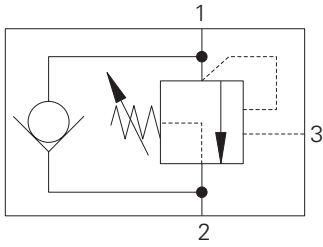

## Sectional View

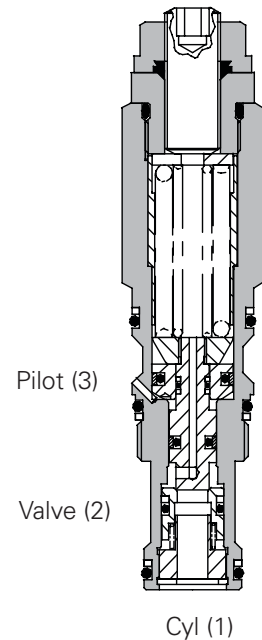

## Operation

The check section allows free flow into the actuator then holds and locks the load against movement. The pilot assisted relief valve section will give controlled movement when pilot pressure is applied. The relief section is normally set to open at a pressure at least 1.3 times the maximum load induced pressure but the pressure required to open the valve and allow movement

depends on the pilot ratio of the valve. For optimization of load control and energy usage, a choice of pilot ratios is available.

The pressure required to open the valve and start actuator movement can be calculated as follows:

$$\text{Pilot Pressure} = \frac{(\text{Relief Setting}) - (\text{Load Pressure})}{\text{Pilot Ratio}}$$

## Features

Cartridge is economical and fits simple cavity. Allows quick, easy field service - reduces down time. Interchangeable with pilot check valve of a similar size.

## Pilot Ratio

4:1 Best suited for applications where load varies and machine structure can induce instability.

## Performance Data

### Ratings and Specifications

Figures based on: Oil Temp = 40°C Viscosity = 32 cSt (150 SUS)

Rated flow	30 L/min (8 USgpm)
Max relief setting	350 bar (5000 psi)
Max load induced pressure	270 bar (4000 psi)
Cartridge material	Working parts hardened and ground steel. External steel surfaces zinc plated.
Mounting position	Unrestricted
Cavity number	A20090-T11A
Torque cartridge into cavity	45 Nm (33 lbs ft)
Weight	0.15 kg (0.33 lbs)
Seal kit number	SK1079 (Nitrile) SK1079V (Viton®)
Recommended filtration level	BS5540/4 Class 18/13 (25 micron nominal)
Operating temperature	-30° to +90°C (-22° to +194°F)
Leakage	0.3 milliliters/min nominal (5 dpm)
Nominal viscosity range	5 to 500 cSt

Viton is a registered trademark of E.I. DuPont

## Description

The 1SER series overcenter valve performs all duties of a regular overcenter but is able to relieve and stay open irrespective of downstream pressure. This enables the valve to operate when used with a closed center directional valve which has service line reliefs. The poppet is pressure balanced, preventing relief setting increase due to back pressure.

## Pressure Drop

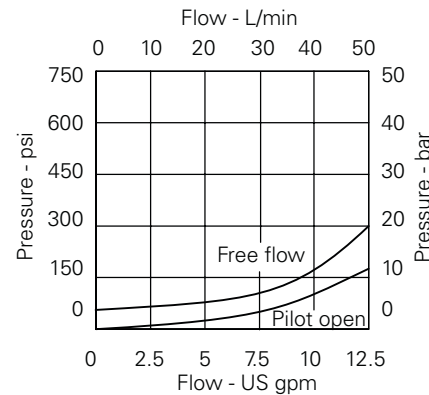

Where measurements are critical request certified drawings. We reserve the right to change specifications without notice.

# 1SER30 - Overcenter Valve

Part balanced, pilot assisted relief with check  
30 L/min (8 USgpm) • 270 bar (4000 psi)

Model Code

**1SER30 - F - 35 S 4**

1   
 2   
 3   
 4   
 5

**1 Function**  
1SER30

**2 Adjustment Means**

**F** - Screw Adjustment  
**N** - Fixed - State pressure setting required

For fixed versions add setting in 10 bar increments to end of part number. Subject to a ±10% tolerance.

**3 Pressure Range @ 4.8 L/min**

**Note:** Code based on pressure in bar.  
**35** - 75-350 bar  
Std setting 210 bar  
Std setting made at 4.8 L/min

**4 Seals**

**S** - Nitrile (For use with most industrial hydraulic oils)  
**SV** - Viton (For high temperature and most special fluid applications)

**5 Pilot Ratio**

4 - 4:1

## Dimensions

mm (inch)

### Cartridge Only

Basic Code  
1SER30

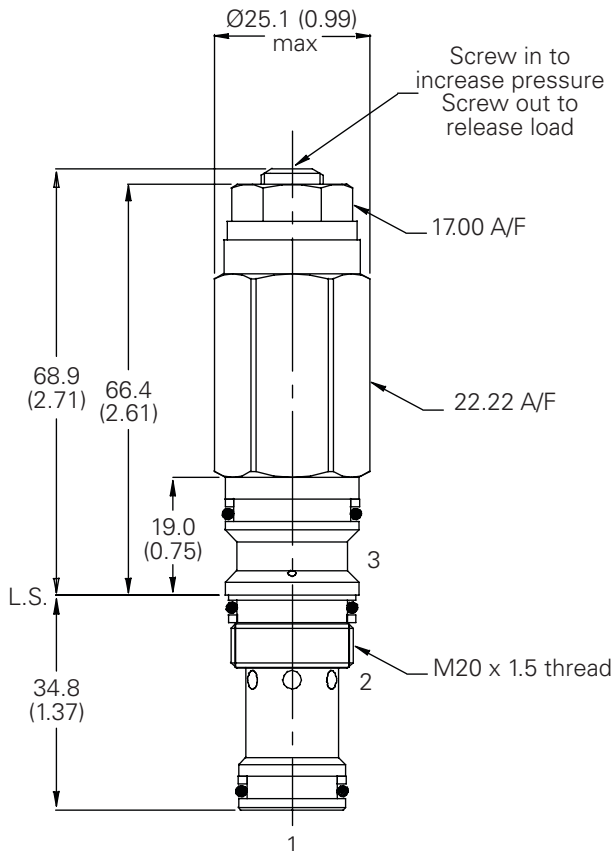

**Note:** Tightening torque of "F" adjuster locknut - 20 to 25 Nm.

### Cavity

Model A20090-T11A  
Form Drill TD-11A  
Form Reamer TR-11A

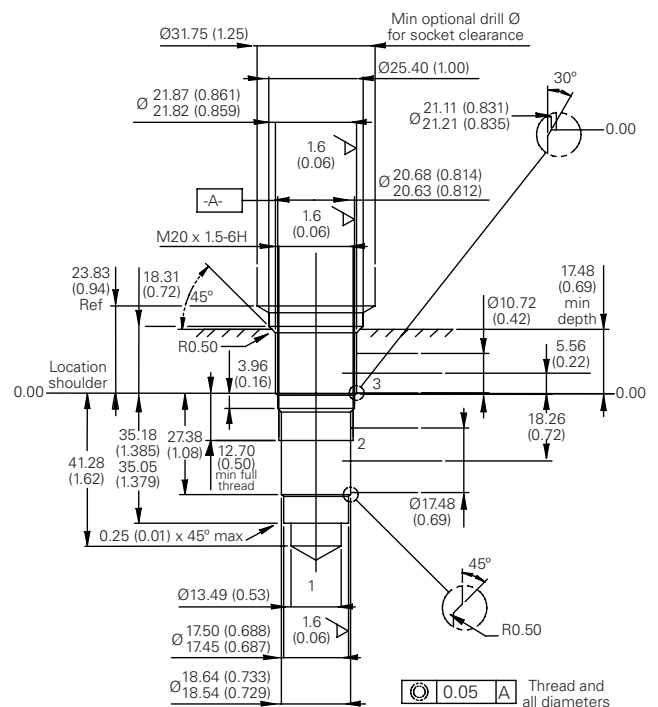

F

# 1SEB30 - Overcenter Valve

Fully balanced, pilot assisted relief with check  
30 L/min (8 USgpm) • 270 bar (4000 psi)

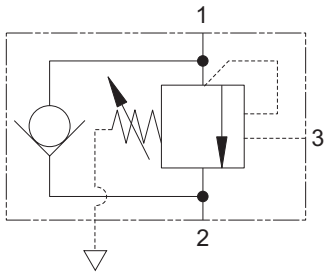

Sectional View

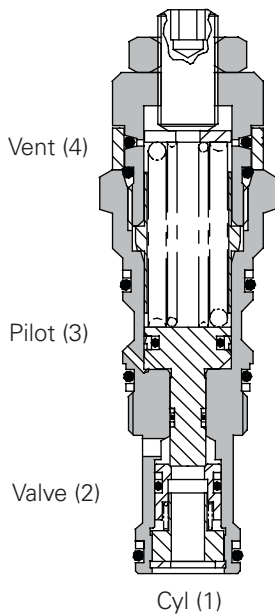

## Operation

The check section allows free flow into the actuator then holds and locks the load against movement. The pilot assisted relief valve section will give controlled movement when pilot pressure is applied. The relief section is normally set to open at a pressure at least 1.3 times the maximum load induced pressure but the pressure required to open the

valve and allow movement depends on the pilot ratio of the valve. For optimization of load control and energy usage, a choice of pilot ratios is available.

The pressure required to open the valve and start actuator movement can be calculated as follows:

$$\text{Pilot Pressure} = \frac{(\text{Relief Setting}) - (\text{Load Pressure})}{\text{Pilot Ratio}}$$

## Features

Cartridge is economical and fits simple cavity. Allows quick, easy field service - reduces down time. Interchangeable with pilot check valve of a similar size.

## Pilot Ratio

5:1

## Performance Data

### Ratings and Specifications

Figures based on: Oil Temp = 40°C Viscosity = 32 cSt (150 SUS)

Rated flow	30 L/min (8 USgpm)
Max relief setting	350 bar (5000 psi)
Max load induced pressure	270 bar (4000 psi)
Cartridge material	Working parts hardened and ground steel. External steel surfaces zinc plated.
Mounting position	Unrestricted
Cavity number	A20090-T11A
Torque cartridge into cavity	45 Nm (33 lbs ft)
Weight	0.14 kg (0.30 lbs)
Seal kit number	SK1079 (Nitrile) SK1079V (Viton®)
Recommended filtration level	BS5540/4 Class 18/13 (25 micron nominal)
Operating temperature	-30° to +90°C (-22° to +194°F)
Leakage	0.3 milliliters/min nominal (5 dpm)
Nominal viscosity range	5 to 500 cSt

## Description

Overcenter valves give static and dynamic control of loads by supplying a counterbalance pressure to the actuator. They prevent runaway in the event of hose burst and hold the load with minimal leakage.

The pressure balanced valve is unaffected by back pressure, allowing service line reliefs to operate and for the valve to be used in regenerative or proportional valve systems.

The overcenter valve should be mounted either into, onto or as close to the actuator as possible to give maximum protection.

Single overcenter valves control unidirectional loads such as in aerial platforms, cranes or winches and dual overcenters are suited to bi-directional motion such as wheel motor applications or cylinders going over center.

## Pressure Drop

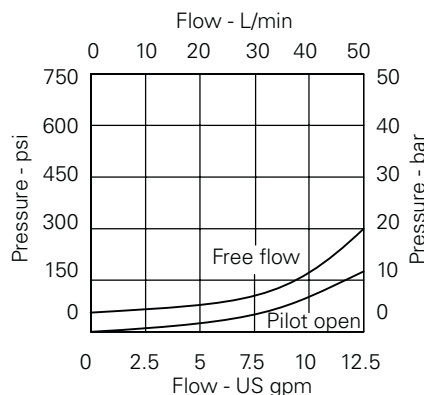

Where measurements are critical request certified drawings. We reserve the right to change specifications without notice.

# 1SEB30 - Overcenter Valve

Fully balanced, pilot assisted relief with check  
30 L/min (8 USgpm) • 270 bar (4000 psi)

## Model Code

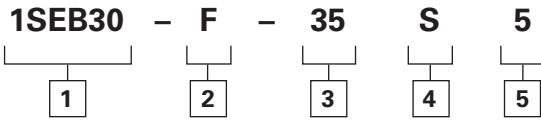

### 1 Function

**1SEB30**

### 2 Adjustment Means

**F** - Screw Adjustment

**N** - Fixed - State pressure setting required

For fixed versions add setting in 10 bar increments to end of part number. Subject to a ±10% tolerance.

### 3 Pressure Range @ 4.8 L/min

**Note:** Code based on pressure in bar.

**35** - 75-350 bar

Std setting 210 bar

Std setting made at 4.8 L/min

### 4 Seals

**S** - Nitrile

(For use with most industrial hydraulic oils)

**SV** - Viton (For high temperature and most special fluid applications)

### 5 Pilot Ratio

**5** - 5:1

## Dimensions

mm (inch)

### Cartridge Only

Basic Code  
1SEB30

### Cavity

Model A20090-T11A  
Form Drill TD-11A  
Form Reamer TR-11A

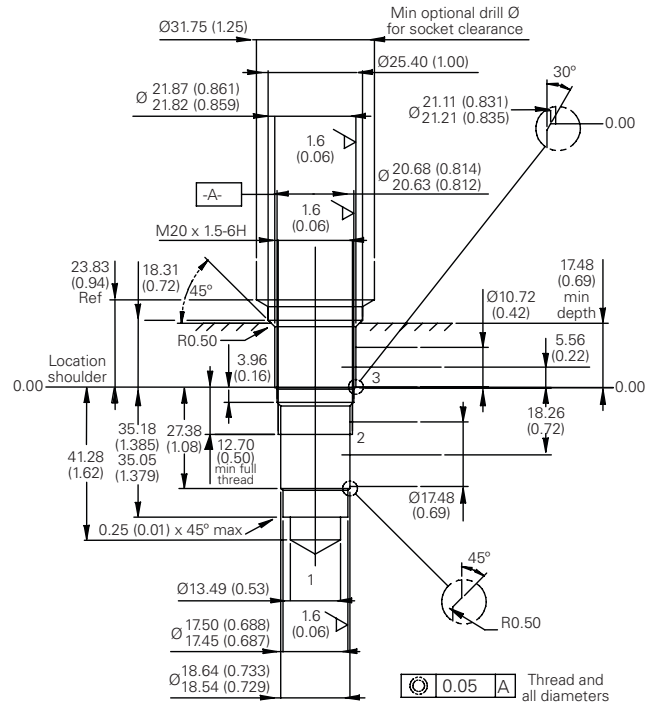
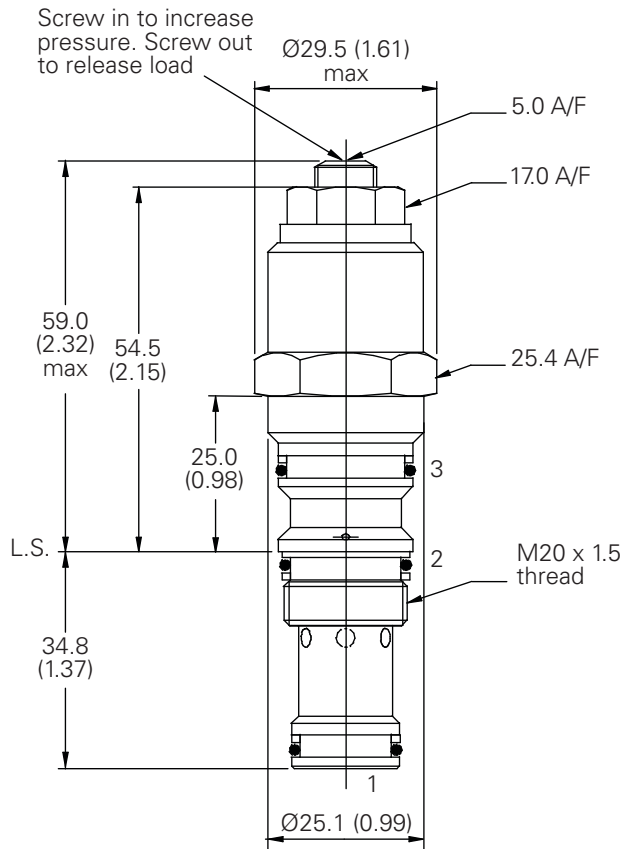

**Note:** Tightening torque of "F" adjuster locknut - 20 to 25 Nm

Where measurements are critical request certified drawings. We reserve the right to change specifications without notice.

# 1SEL30 - Overcenter Valve

Counterbalanced, pilot assisted relief with check

30 L/min (8 USgpm) • 380 bar (5510 psi)

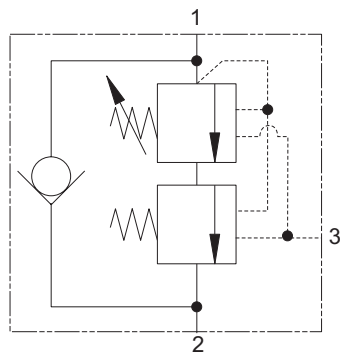

## Operation

The check section allows free flow and then locks the load against movement. The pilot assisted relief valve section will give controlled movement when pilot pressure is applied, maintaining a counterbalance pressure to prevent initial

pressure loss and therefore instability. The total pressure setting will normally be set at 1.3 times the load induced pressure. The counterbalance pressure reduces as the pilot pressure increases.

## Features

Cartridge is economical and fits simple cavity. Allows quick, easy field service - reduces down time. Interchangeable with pilot check valve of a similar size.

## Pilot Ratio

Primary 4.3:1

Secondary 0.4:1

## Sectional View

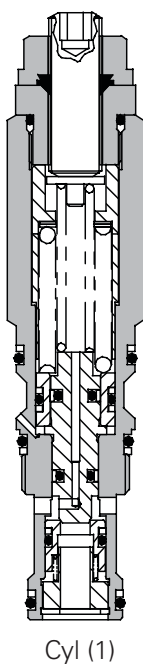

## Performance Data

### Ratings and Specifications

Figures based on: Oil Temp = 40°C Viscosity = 32 cSt (150 SUS)

Rated flow	30 L/min (8 USgpm)
Max setting	380 bar (5510 psi)
Cartridge material	Working parts hardened and ground steel. External steel surfaces zinc plated.
Mounting position	Unrestricted
Cavity number	A20090-T11A
Torque cartridge into cavity	45 Nm (33 lbs ft)
Weight	0.15 kg (0.33 lbs)
Seal kit number	SK1079 (Nitrile) SK1079V (Viton®)
Recommended filtration level	BS5540/4 Class 18/13 (25 micron nominal)
Operating temperature	-30° to +90°C (-22° to +194°F)
Leakage	0.3 milliliters/min nominal (5 dpm)
Nominal viscosity range	5 to 500 cSt

Viton is a registered trademark of E.I. DuPont

F

## Description

The 1SEL overcenter valve performs all duties of a regular overcenter but maintains a counterbalance pressure to provide dampening of cylinders when there is a rapid loss in stored pressure. This counterbalance pressure reduces as the pilot pressure increases. Typical applications include extension cylinders on telescopic handlers where it is important to have a smooth operation when retracting from full extension.

## Pressure Drop

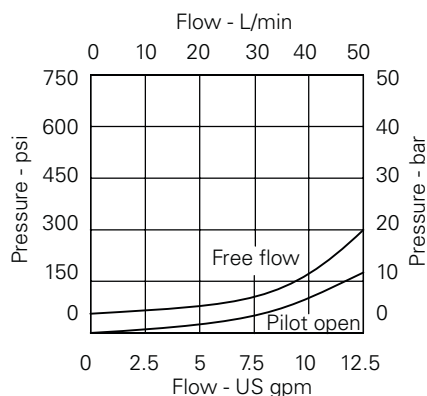

**Note:** This valve has been designed to eliminate boom instability from flexible boom applications or where the load induced pressure varies greatly. To get the best results, the settings should be adjusted for each application and then factory set for production quantities. Please contact our Technical Department for more information.

Where measurements are critical request certified drawings. We reserve the right to change specifications without notice.

# 1SEL30 - Overcenter Valve

Counterbalanced, pilot assisted relief with check  
30 L/min (8 USgpm) • 380 bar (5510 psi)

Model Code

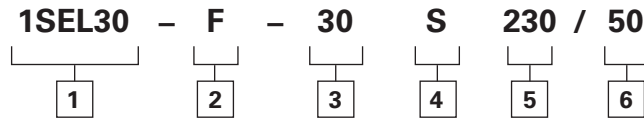

**1 Function**  
1SEL30

---

**2 Adjustment Means Counterbalance Setting**  
F - Screw Adjustment  
N - Fixed - State pressure setting required

For fixed versions add setting in 10 bar increments to end of part number. Subject to a ±10% tolerance.

**3 Pressure Range @ 4.8 L/min**  
**Note:** Code based on pressure in bar.  
20 - 170-300 bar Std setting 220 bar (170/50)  
30 - 240-370 bar Std setting 280 bar (230/50)  
40 - 270-380 bar Std setting 350 bar (300/50)  
Std setting at 4.8 L/min

---

**4 Seals**  
S - Nitrile (For use with most industrial hydraulic oils)  
SV - Viton (For high temperature and most special fluid applications)

**5 High Pressure Setting Bar**  
(10 bar increments)  
130 to 310 bar (2175 to 5000 psi)

---

**6 Counterbalance Setting Bar**  
(10 bar increments)  
20 to 120 bar (300 to 1740 psi)

## Dimensions

mm (inch)

**Cartridge Only**  
Basic Code  
1SEL30

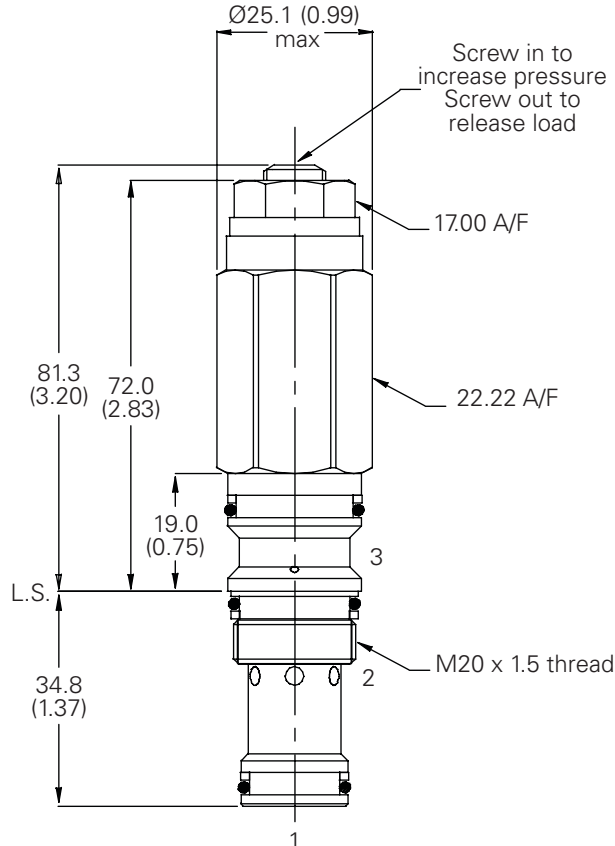

## Cavity

Model A20090-T11A  
Form Drill TD-11A  
Form Reamer TR-11A

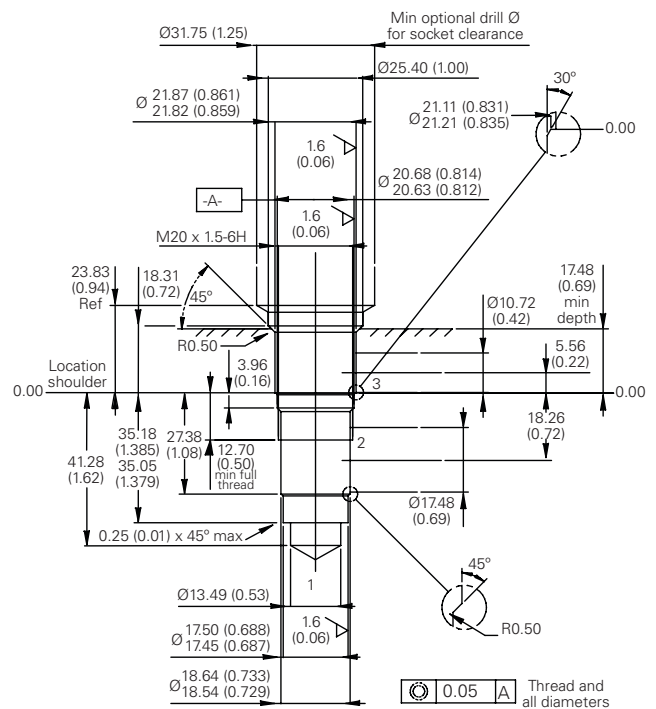

**Note:** Tightening torque of "F" adjuster locknut - 20 to 25 Nm

Where measurements are critical request certified drawings. We reserve the right to change specifications without notice.

# ISE90 - Overcenter Valve

Pilot assisted relief with check

90 L/min (23 USgpm) • 270 bar (4000 psi)

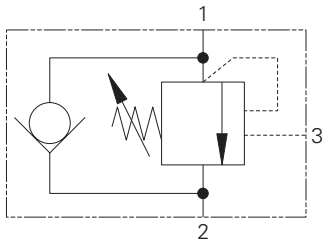

Sectional View

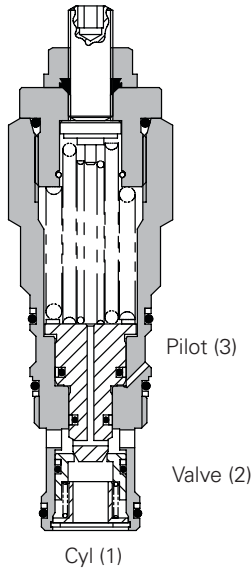

## Description

Overcenter valves give static and dynamic control of loads by regulating the flow into and out of hydraulic actuators. When installed close to or within an actuator, the overcenter valve will stop runaway in the event of hose burst and if open center directional control valves are used, will allow thermal expansion relief of the hydraulic fluid.

The overcenter cartridge is ideal for mounting directly into a cavity machined in the body of the cylinder, motor or rotary actuator. The cartridge can also be mounted directly to the ports via a specifically machined body as part of a Hydraulic Integrated Circuit or single unit, or contained within one of our standard line bodies.

Single overcenter valves are normally used when the load is unidirectional, for example an aerial platform or crane and dual overcenter valves are used for controlling loads in both directional for motor applications or for cylinders going over center.

Where measurements are critical request certified drawings. We reserve the right to change specifications without notice.

## Operation

The check section allows free flow into the actuator then holds and locks the load against movement. The pilot assisted relief valve section will give controlled movement when pilot pressure is applied. The relief section is normally set to open at a pressure at least 1.3 times the maximum load induced pressure but the pressure required to open the valve and allow movement

depends on the pilot ratio of the valve. For optimization of load control and energy usage, a choice of pilot ratios is available.

The pressure required to open the valve and start actuator movement can be calculated as follows:

$$\text{Pilot Pressure} = \frac{(\text{Relief Setting}) - (\text{Load Pressure})}{\text{Pilot Ratio}}$$

## Features

Cartridge is economical and fits simple cavity. Allows quick, easy field service - reduces down time. Interchangeable with pilot check valve of a similar size.

## Pilot Ratio

4:1 Best suited for applications where the load remains relatively constant.

Other ratios available on request.

## Performance Data

### Ratings and Specifications

Figures based on: Oil Temp = 40°C Viscosity = 32 cSt (150 SUS)

Rated flow	90 L/min (23 USgpm)
Max relief setting	350 bar (5000 psi)
Max load induced pressure:	270 bar (4000 psi)
Cartridge material	Working parts hardened and ground steel. External steel surfaces zinc plated.
Mounting position	Unrestricted
Cavity number	A20092-T2A
Torque cartridge into cavity	60 Nm (44 lbs ft)
Weight	0.42 kg (0.92 lbs)
Seal kit number	SK1093 (Nitrile) SK1093V (Viton®)
Recommended filtration level	BS5540/4 Class 18/13 (25 micron nominal)
Operating temperature	-30° to +90°C (-22° to +194°F)
Leakage	0.3 milliliters/min nominal (5 dpm)
Nominal viscosity range	5 to 500 cSt

Viton is a registered trademark of E.I. DuPont

## Pressure Drop

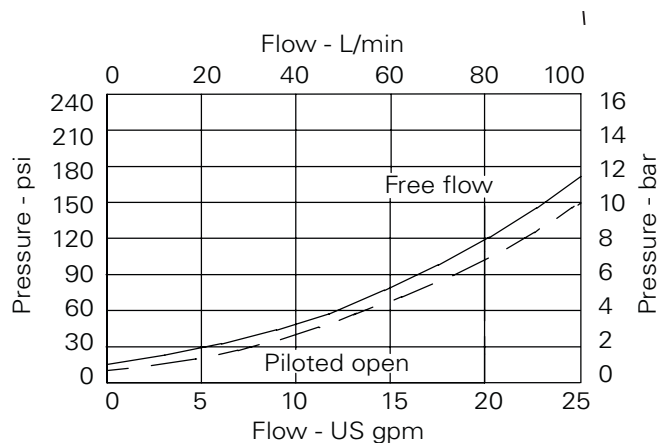

# ISE90 - Overcenter Valve

Pilot assisted relief with check

90 L/min (23 USgpm) • 270 bar (4000 psi)

## Model Code

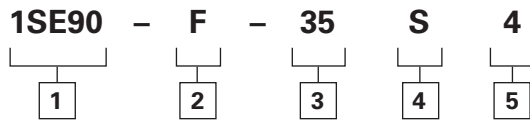

### 1 Function

**1SE90**

### 2 Adjustment Means

**F** - Screw Adjustment  
**N** - Fixed - State pressure setting required

For fixed versions add setting in 10 bar increments to end of part number. Subject to a ±10% tolerance.

### 3 Pressure Range @ 4.8 L/min

**Note:** Code based on pressure in bar.

**20** - (All pilot ratios):  
 70-225 bar  
 Std setting 100 bar

**35** - (2.5:1 and 5:1):  
 70-350 bar  
 Std setting 210 bar  
 (10:1): 90-350 bar  
 Std setting 210 bar

Std setting made at 4.8 L/min

### 4 Seals

**S** - Nitrile (For use with most industrial hydraulic oils)  
**SV** - Viton (For high temperature and most special fluid applications)

### 5 Pilot Ratio

**4** - 4:1  
 Other ratios available upon request

## Dimensions

mm (inch)

### Cartridge Only

Basic Code  
 1SE90

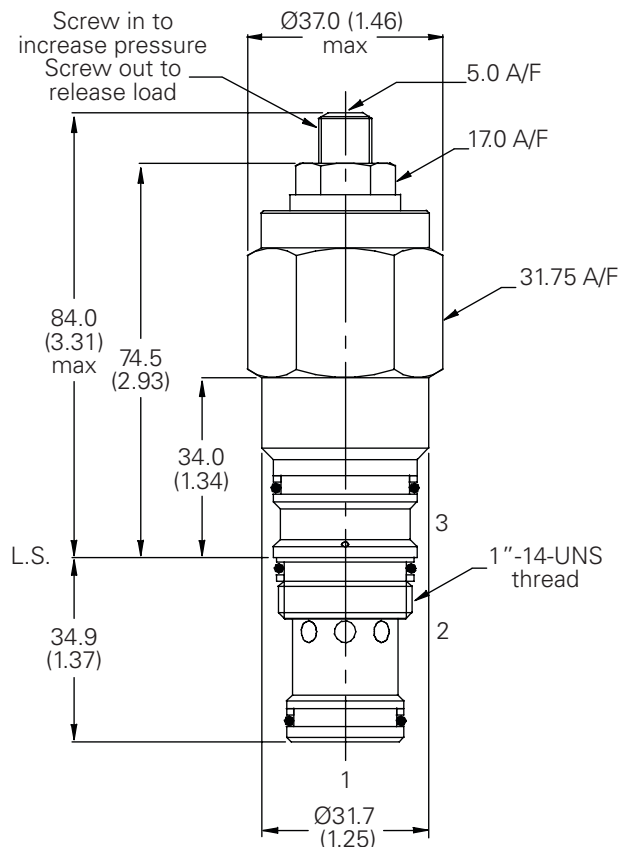

**Note:** Tightening torque of "F" adjuster locknut - 20 to 25 Nm.

### Cavity

Model A20092-T2A  
 Form Drill TD-2A  
 Form Reamer TR-2A

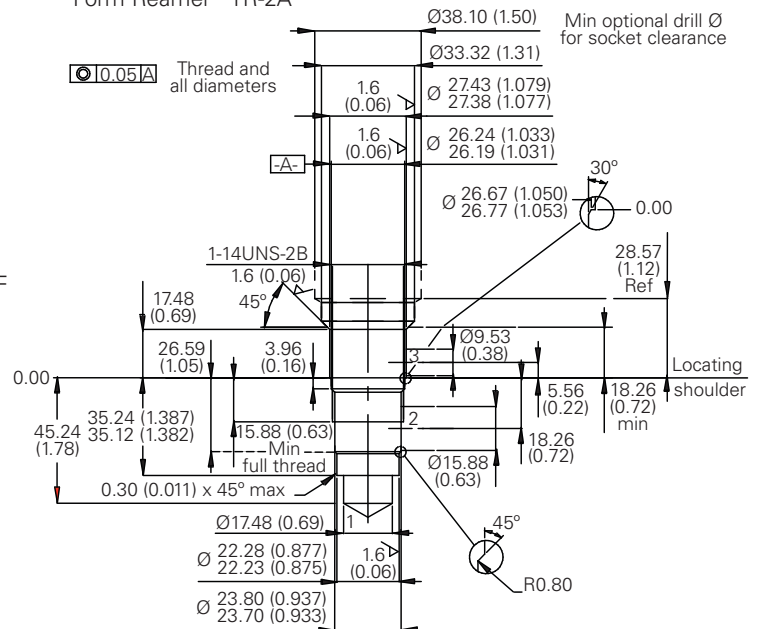

Where measurements are critical request certified drawings. We reserve the right to change specifications without notice.

# 1SER90 - Overcenter Valve

Part balanced, pilot assisted relief with check  
90 L/min (23 USgpm) • 270 bar (4000 psi)

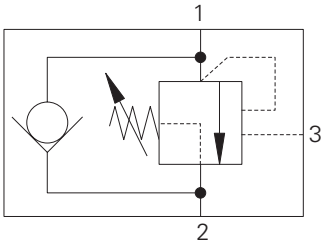

Sectional View

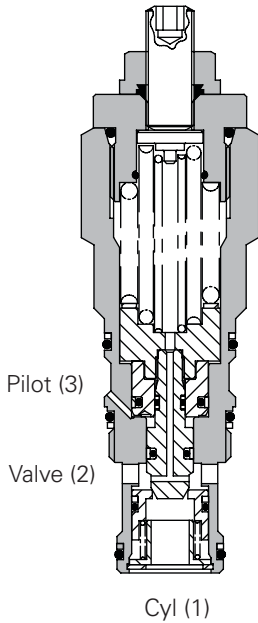

## Operation

The check section allows free flow into the actuator then holds and locks the load against movement. The pilot assisted relief valve section will give controlled movement when pilot pressure is applied. The relief section is normally set to open at a pressure at least 1.3 times the maximum load induced pressure but the pressure required to open the valve and allow movement

depends on the pilot ratio of the valve. For optimization of load control and energy usage, a choice of pilot ratios is available.

The pressure required to open the valve and start actuator movement can be calculated as follows:

$$\text{Pilot Pressure} = \frac{(\text{Relief Setting}) - (\text{Load Pressure})}{\text{Pilot Ratio}}$$

## Features

Cartridge is economical and fits simple cavity. Allows quick, easy field service - reduces down time. Interchangeable with pilot check valve of a similar size.

## Pilot Ratio

4:1 Best suited for applications where the load remains relatively constant.

Other ratios available on request.

## Performance Data

### Ratings and Specifications

Figures based on: Oil Temp = 40°C Viscosity = 32 cSt (150 SUS)

Rated flow	90 L/min (23 USgpm)
Max relief setting	350 bar (5000 psi)
Max load induced pressure:	270 bar (4000 psi)
Cartridge material	Working parts hardened and ground steel. External steel surfaces zinc plated.
Mounting position	Unrestricted
Cavity number	A20092-T2A
Torque cartridge into cavity	60 Nm (44 lbs ft)
Weight	0.42 kg (0.92 lbs)
Seal kit number	SK1093 (Nitrile) SK1093V (Viton®)
Recommended filtration level	BS5540/4 Class 18/13 (25 micron nominal)
Operating temperature	-30° to +90°C (-22° to +194°F)
Leakage	0.3 milliliters/min nominal (5 dpm)
Nominal viscosity range	5 to 500 cSt

Viton is a registered trademark of E.I. DuPont

## Description

The 1SER series overcenter valve performs all duties of a regular overcenter but is able to relieve and stay open irrespective of downstream pressure. This enables the valve to operate when used with a closed center directional valve which has service line reliefs. The poppet is pressure balanced, preventing relief setting increase due to back pressure.

## Pressure Drop

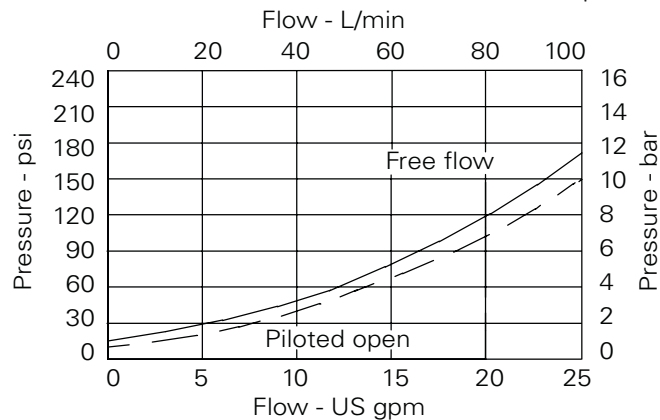

Where measurements are critical request certified drawings. We reserve the right to change specifications without notice.

# 1SER90 - Overcenter Valve

Part balanced, pilot assisted relief with check  
90 L/min (23 USgpm) • 270 bar (4000 psi)

## Model Code

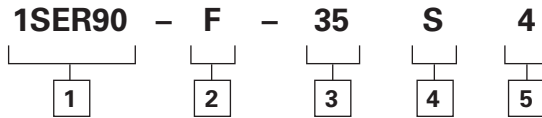

**1 Function**  
**1SER30**

### 2 Adjustment Means

**F** - Screw Adjustment  
**N** - Fixed - State pressure setting required

For fixed versions add setting in 10 bar increments to end of part number. Subject to a ±10% tolerance.

**3 Pressure Range @ 4.8 L/min**

**Note:** Code based on pressure in bar.

**20** - 70-225 bar  
Std setting 100 bar  
**35** - 70-350 bar  
Std setting 210 bar

Std setting made at 4.8 L/min

**4 Seals**

**S** - Nitrile (For use with most industrial hydraulic oils)  
**SV** - Viton (For high temperature and most special fluid applications)

**5 Pilot Ratio**

**4 - 4:1**

Other ratios available upon request

## Dimensions

mm (inch)

### Cartridge Only

Basic Code  
1SER90

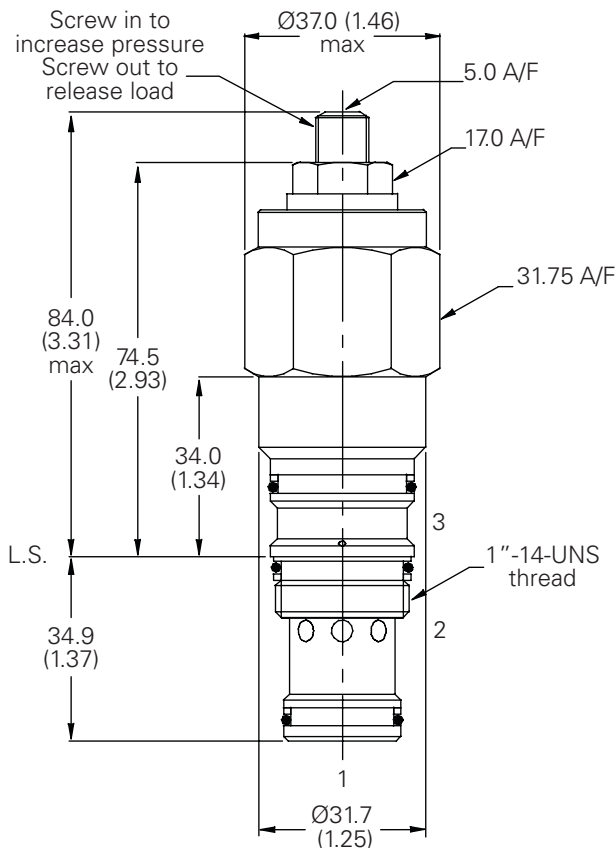

### Cavity

Model A20092-T2A  
Form Drill TD-2A  
Form Reamer TR-2A

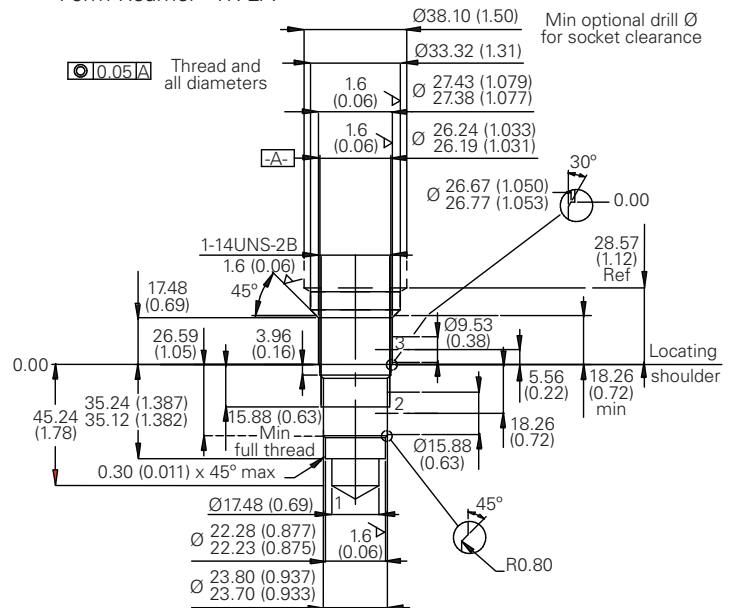

**Note:** Tightening torque of "F" adjuster locknut - 20 to 25 Nm.

Where measurements are critical request certified drawings. We reserve the right to change specifications without notice.

# ISEB90 - Overcenter Valve

Fully balanced, pilot assisted relief with check  
90 L/min (23 USgpm) • 270 bar (4000 psi)

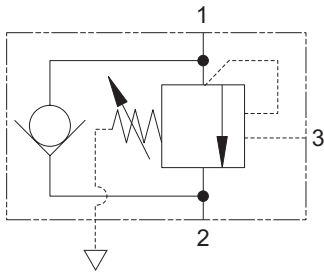

Sectional View

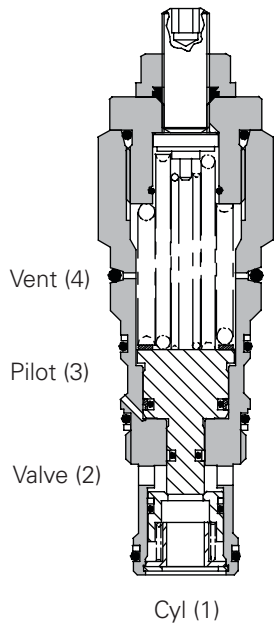

## Operation

The check section allows free flow into the actuator then holds and locks the load against movement. The pilot assisted relief valve section will give controlled movement when pilot pressure is applied. The relief section is normally set to open at a pressure at least 1.3 times the maximum load induced pressure but the pressure required to open the valve and allow movement

depends on the pilot ratio of the valve. For optimization of load control and energy usage, a choice of pilot ratios is available.

The pressure required to open the valve and start actuator movement can be calculated as follows

$$\text{Pilot Pressure} = \frac{(\text{Relief Setting}) - (\text{Load Pressure})}{\text{Pilot Ratio}}$$

## Feature

Cartridge is economical and fits simple cavity. Allows quick, easy field service - reduces down time. Interchangeable with pilot check valve of a similar size.

## Pilot Ratio

4:1 Best suited for applications where the load remains relatively constant.

Other ratios available on request.

## Performance Data

### Ratings and Specifications

Figures based on: Oil Temp = 40°C Viscosity = 32 cSt (150 SUS)

Rated flow	90 L/min (23 USgpm)
Max relief setting	350 bar (5000 psi)
Max load induced pressure	270 bar (4000 psi)
Cartridge material	Working parts hardened and ground steel. External steel surfaces zinc plated.
Mounting position	Unrestricted
Cavity number	A20092-T2A
Torque cartridge into cavity	60 Nm (44 lbs ft)
Weight	0.42 kg (0.92 lbs)
Seal kit number	SK1096 (Nitrile) SK1096V (Viton)
Recommended filtration level	BS5540/4 Class 18/13 (25 micron nominal)
Operating temperature	-30°C to +90°C (-22° to +194°F)
Leakage	0.3 milliliters/min nominal (5 dpm)
Nominal viscosity range	5 to 500 cSt

Viton is a registered trademark of E.I. DuPont

## Description

Overcenter valves give static and dynamic control of loads by supplying a counterbalance pressure to the actuator. They prevent runaway in the event of hose burst and hold the load with minimal leakage.

The pressure balanced valve is unaffected by back pressure, allowing service line reliefs to operate and for the valve to be used in regenerative or proportional valve systems.

The overcenter valve should be mounted either into, onto or as close to the actuator as possible to give maximum protection.

Single overcenter valves control unidirectional loads such as in aerial platforms, cranes or winches and dual overcenters are suited to bi-directional motion such as wheel motor applications or cylinders going over center.

Where measurements are critical request certified drawings. We reserve the right to change specifications without notice.

## Pressure Drop

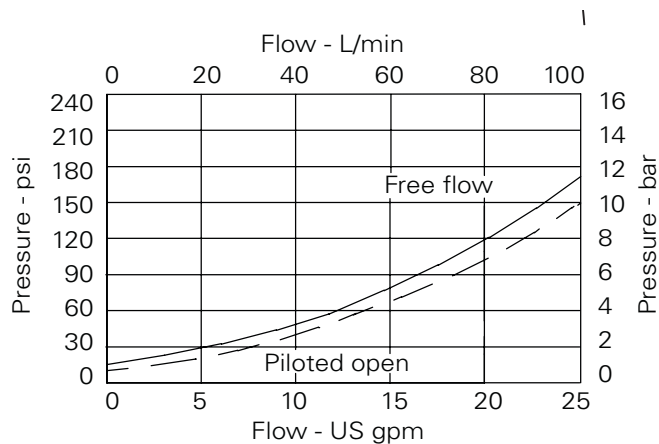

# 1SEB90 - Overcenter Valve

Fully balanced, pilot assisted relief with check  
 90 L/min (23 USgpm) • 270 bar (4000 psi)

Model Code

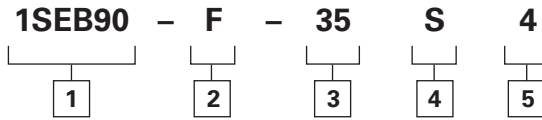

## 1 Basic Code

**1SEB90**

## 2 Adjustment Means

**F** - Screw Adjustment  
**N** - Fixed - State pressure setting required

For fixed versions add setting in 10 bar increments to end of part number. Subject to a ±10% tolerance.

## 3 Pressure Range

**Note:** Code based on pressure in bar.

**20** - 70-225 bar.  
 Std setting 100 bar

**35** - 75-350 bar.  
 Std setting 210 bar

Std setting made at 4.8 L/min

## 4 Seals

**S** - Nitrile (For use with most industrial hydraulic oils)

**SV** - Viton (For high temperature and most special fluid applications)

## 5 Pilot Ratio

**4 - 4:1**

Other ratios available upon request

## Dimensions

mm (inch)

### Cartridge Only

Basic Code  
 1SEB90

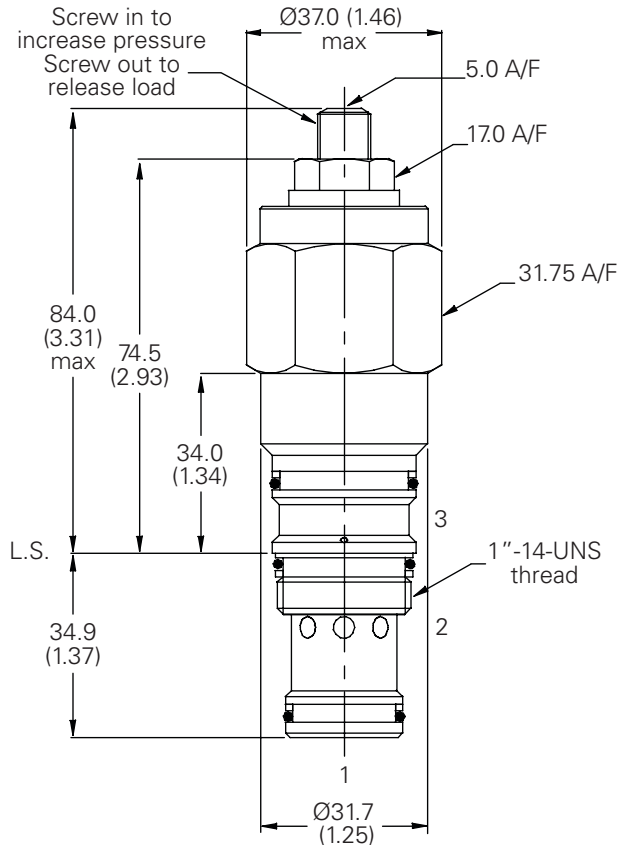

**Note:** Tightening torque of "F" adjuster locknut - 20 to 25 Nm

### Cavity

Model A20092-T2A  
 Form Drill TD-2A  
 Form Reamer TR-2A

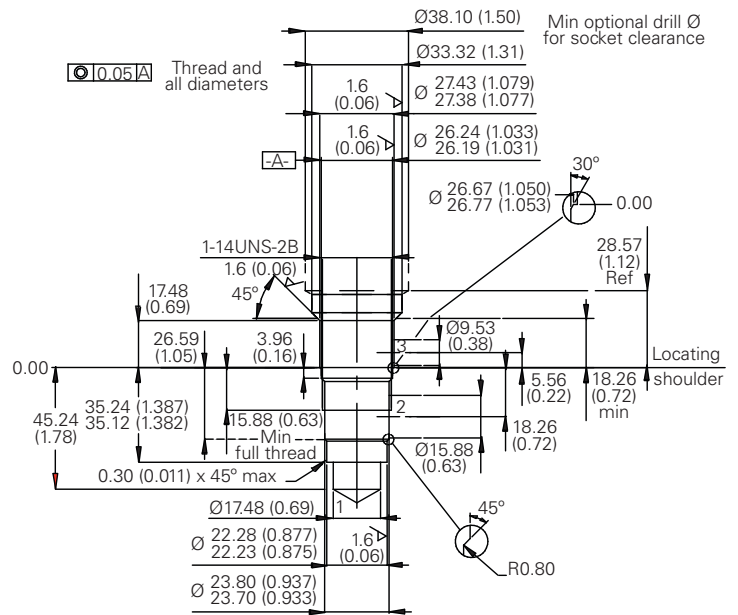

Where measurements are critical request certified drawings. We reserve the right to change specifications without notice.

# ISEL90 - Overcenter Valve

Counterbalance, pilot assisted relief with check

90 L/min (23 USgpm) • 380 bar (5510 psi)

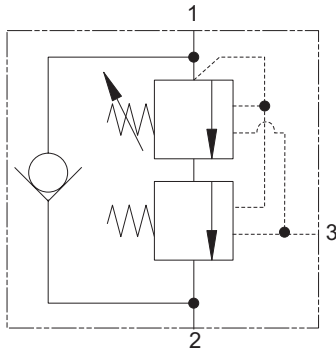

### Operation

The check section allows free flow and then locks the load against movement. The pilot assisted relief valve section will give controlled movement when pilot pressure is applied, maintaining a counterbalance pressure to prevent initial

pressure loss and therefore instability. The total pressure setting will normally be set at 1.3 times the load induced pressure. The counterbalance pressure reduces as the pilot pressure increases.

### Features

Cartridge is economical and fits simple cavity. Allows quick, easy field service - reduces down time. Interchangeable with pilot check valve of a similar size.

### Pilot Ratio

Primary 5.6:1

Secondary 0.7:1

### Sectional View

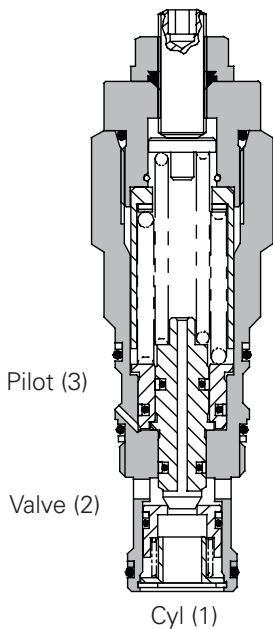

### Performance Data

#### Ratings and Specifications

Figures based on: Oil Temp = 40°C Viscosity = 32 cSt (150 SUS)

Rated flow	90 L/min (23 USgpm)
Max setting	380 bar (5510 psi)
Cartridge material	Working parts hardened and ground steel. External steel surfaces zinc plated.
Mounting position	Unrestricted
Cavity number	A20092-T2A
Torque cartridge into cavity	60 Nm (44 lbs ft)
Weight	0.42 kg (0.92 lbs)
Seal kit number	SK1093 (Nitrile) SK1093V (Viton®)
Recommended filtration level	BS5540/4 Class 18/13 (25 micron nominal)
Operation temperature	-30° to +90°C (-22° to +194°F)
Leakage	0.3 milliliters/min nominal (5 dpm)
Nominal viscosity range	5 to 500 cSt

Viton is a registered trademark of E.I. DuPont

### Pressure Drop

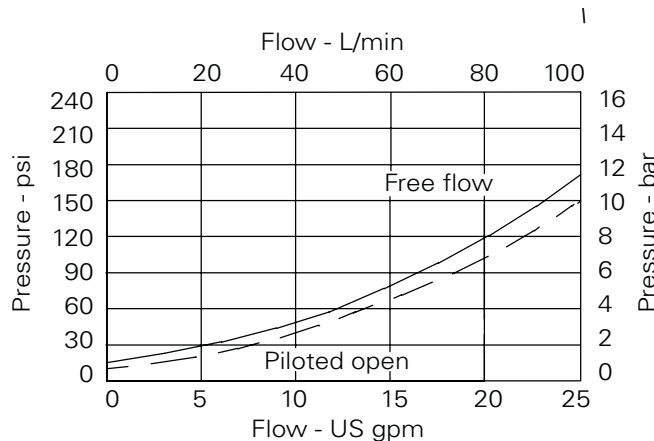

**Note:** This valve has been designed to eliminate instability from flexible boom applications or where the load induced pressure varies greatly. To get the best results, the settings should be adjusted for each application and then factory set for production quantities. Please contact Technical Department for more information.

### Description

The ISEL overcenter valve performs all duties of a regular overcenter but maintains a counterbalance pressure to provide dampening of cylinders when there is a rapid loss in stored pressure. This counterbalance pressure reduces as the pilot pressure increases. Typical applications include extension cylinders on telescopic handlers where it is important to have a smooth operation when retracting from full extension.

Where measurements are critical request certified drawings. We reserve the right to change specifications without notice.

# ISEL90 - Overcenter Valve

Counterbalance, pilot assisted relief with check  
 90 L/min (23 USgpm) • 380 bar (5510 psi)

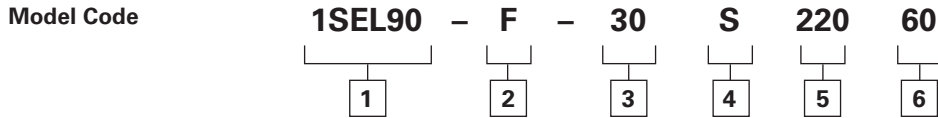

**1 Function**  
**1SEL90 -**

**2 Adjustment Means Counterbalance Setting**

**F** - Screw Adjustment  
**N** - Fixed - State pressure setting required

For fixed versions add setting in 10 bar increments to end of part number. Subject to a ±10% tolerance.

**3 Pressure Range @ 4.8 L/min**

**Note:** Code based on pressure in bar.  
**20** - 170-350 bar  
 Std setting 220 bar (160/60)  
**35** - 210-380 bar  
 Std setting 250 bar (220/60)  
 Std setting made at 4.8 L/min

**4 Seals**

**S** - Nitrile (For use with most industrial hydraulic oils)  
**SV** - Viton (For high temperature and most special fluid applications)

**5 High Pressure Setting Bar**

(10 bar increments).  
 150 to 650 bar (2175 to 3335 psi)

**6 Counterbalance Setting Bar**

(10 bar increments).  
 20 to 170 bar (100 to 250 psi)

## Dimensions

mm (inch)

### Cartridge Only

Basic Code  
 1SEL90

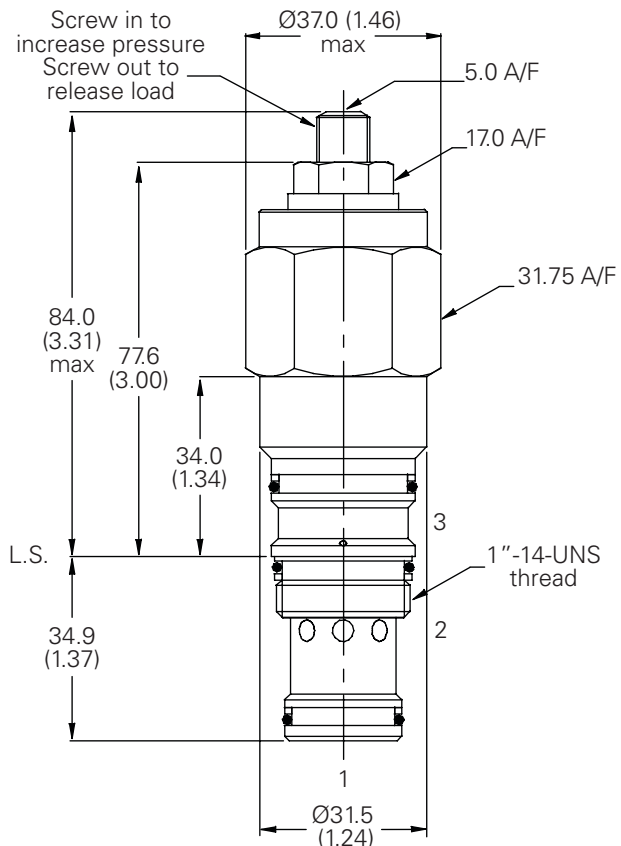

### Cavity

Model                      A20092-T2A  
 Form Drill                TD-2A  
 Form Reamer            TR-2A

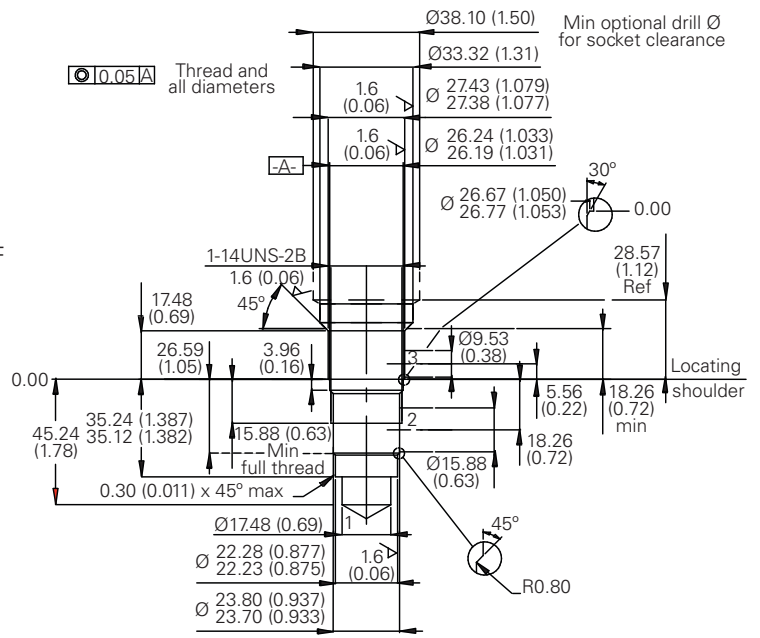

**Note:** Tightening torque of "F" adjuster locknut - 20 to 25 Nm

Where measurements are critical request certified drawings. We reserve the right to change specifications without notice.



# ISE140 - Overcenter Valve

Pilot assisted relief with check

140 L/min (37 USgpm) • 340 bar (4930 psi)

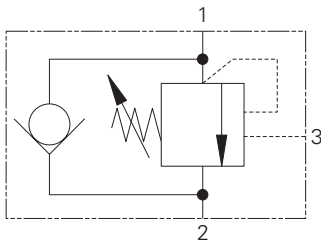

Sectional View

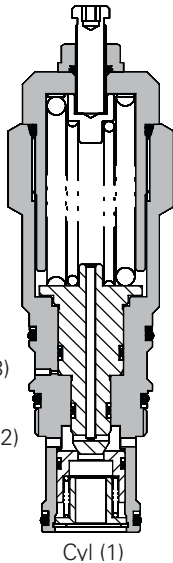

## Operation

The check section allows free flow into the actuator then holds and locks the load against movement. The pilot assisted relief valve section will give controlled movement when pilot pressure is applied. The relief section is normally set to open at a pressure at least 1.3 times the maximum load induced pressure but the pressure required to open the

valve and allow movement depends on the pilot ratio of the valve. For optimization of load control and energy usage, a choice of pilot ratios is available.

The pressure required to open the valve and start actuator movement can be calculated as follows:

$$\text{Pilot Pressure} = \frac{(\text{Relief Setting}) - (\text{Load Pressure})}{\text{Pilot Ratio}}$$

## Features

Cartridge is economical and fits simple cavity. Allows quick, easy field service - reduces down time. Interchangeable with pilot check valve of a similar size.

## Pilot Ratio

4:1 Best suited for applications where load varies and machine structure can induce instability.

6:1 Best suited for applications where the load remains relatively constant.

Other options available upon request.

## Performance Data

### Ratings and Specifications

Figures based on: Oil Temp = 40°C Viscosity = 32 cSt (150 SUS)

Rated flow	140 L/min (37 USgpm)
Max relief setting	420 bar (6090 psi)
Max load induced pressure	340 bar (4930 psi)
Cartridge material	Working parts hardened and ground steel. External steel surfaces zinc plated.
Mounting position	Unrestricted
Cavity number	A20094-T17A
Torque cartridge into cavity	150 Nm (110 lbs ft)
Weight	1.2 kg (2.5 lbs)
Seal kit number	SK1116 (Nitrile) SK1116V (Viton®)
Recommended filtration level	BS5540/4 Class 18/13 (25 micron nominal)
Operation temperature	-30° to +90°C (-22° to +194°F)
Leakage	0.3 milliliters/min nominal (5 dpm)
Nominal viscosity range	5 to 500 cSt

Viton is a registered trademark of E.I. DuPont

## Pressure Drop

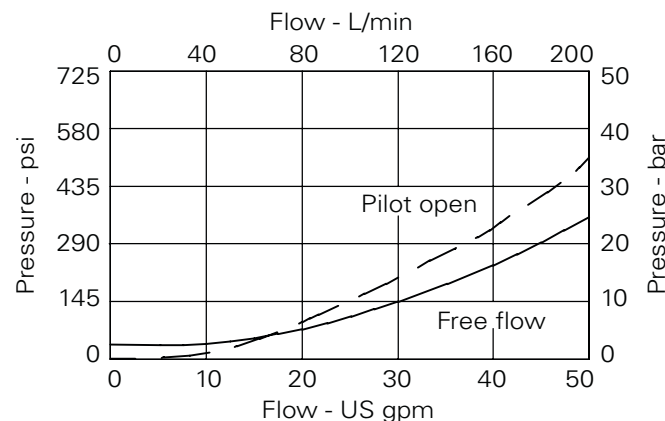

## Description

Overcenter valves give static and dynamic control of loads by regulating the flow into and out of hydraulic actuators. When installed close to or within an actuator, the overcenter valve will stop runaway in the event of hose burst and if open center directional control valves are used, will allow thermal expansion relief of the hydraulic fluid.

The overcenter cartridge is ideal for mounting directly into a cavity machined in the body of the cylinder, motor or rotary actuator. The cartridge can also be mounted directly to the ports via a specifically machined body as part of a Hydraulic Integrated Circuit or single unit, or contained within one of our standard line bodies.

Single overcenter valves are normally used when the load is unidirectional, for example an aerial platform or crane and dual overcenter valves are used for controlling loads in both directional for motor applications or for cylinders going over center.

Where measurements are critical request certified drawings. We reserve the right to change specifications without notice.

# 1SE140 - Overcenter Valve

Pilot assisted relief with check

140 L/min (37 USgpm) • 340 bar (4930 psi)

**Model Code**                      **1SE\*\*\*\* - F - 40 S 4**

1      2      3      4      5

**1 Basic Code**  
1SE140

**2 Adjustment Means**

**F** - Screw Adjustment  
**N** - Fixed - State pressure setting required

For fixed versions add setting in 10 bar increments to end of part number. Subject to a ±10% tolerance.

**3 Pressure Range @ 4.8 L/min**

**Note:** Code based on pressure in bar.

**20** - 140-250 bar.  
Std setting 190 bar  
**30** - 220-330 bar.  
Std setting 270 bar  
**40** - 310-420 bar.  
Std setting 370 bar  
Std setting made at 4.8 L/min

**4 Seals**

**S** - Nitrile (For use with most industrial hydraulic oils)  
**SV** - Viton (For high temperature and most special fluid applications)

**5 Pilot Ratio**

**4** - 4:1  
**6** - 6:1  
Other ratios available upon request

**Dimensions**

mm (inch)

**Cartridge Only**

Basic Code  
1SE140

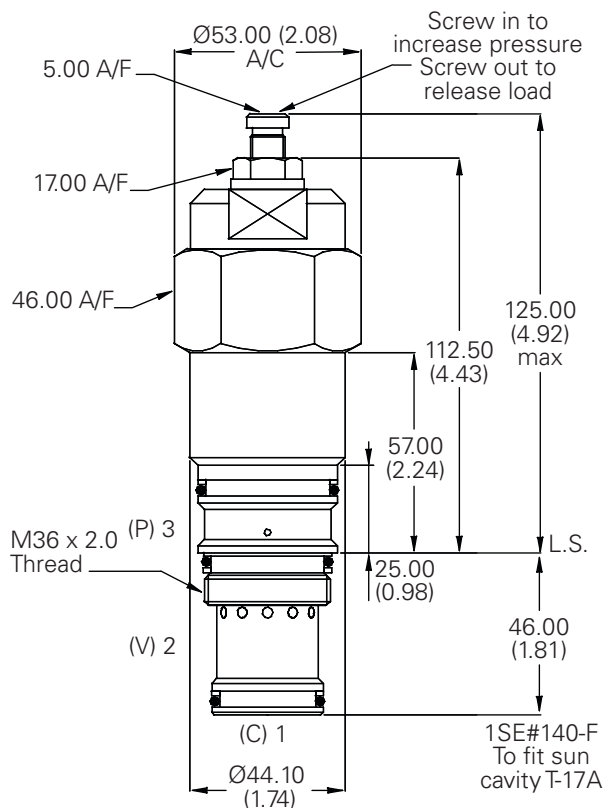

**Cavity**

Model                      A20094-T17A  
Form Drill                TD-17A  
Form Reamer            TR17A

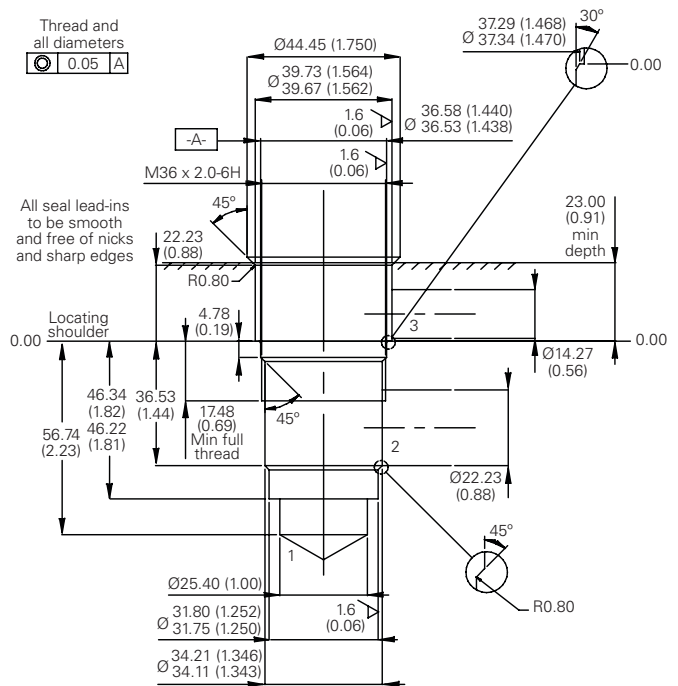

**Note:** Tightening torque of "F" adjuster locknut - 20 to 25 Nm.

Where measurements are critical request certified drawings. We reserve the right to change specifications without notice.

# 1SER140 - Overcenter Valve

Part balanced pilot assisted relief with check  
 140 L/min (37 USgpm) • 340 bar (4930 psi)

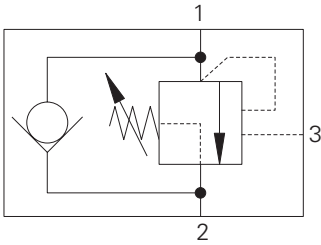

Sectional View

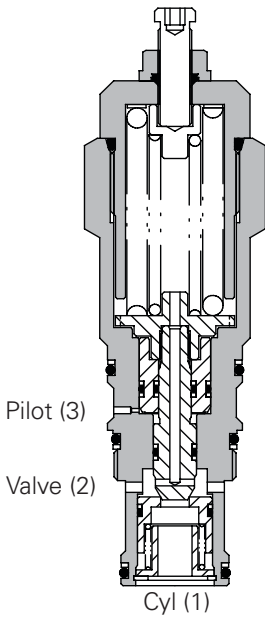

## Operation

The check section allows free flow into the actuator then holds and locks the load against movement. The pilot assisted relief valve section will give controlled movement when pilot pressure is applied. The relief section is normally set to open at a pressure at least 1.3 times the maximum load induced pressure but the pressure required to open the valve and allow movement

depends on the pilot ratio of the valve. For optimization of load control and energy usage, a choice of pilot ratios is available.

The pressure required to open the valve and start actuator movement can be calculated as follows:

$$\text{Pilot Pressure} = \frac{(\text{Relief Setting}) - (\text{Load Pressure})}{\text{Pilot Ratio}}$$

## Features

Cartridge is economical and fits simple cavity. Allows quick, easy field service - reduces down time. Interchangeable with pilot check valve of a similar size.

## Pilot Ratio

4:1 Best suited for applications where load varies and machine structure can induce instability.

6:1 Best suited for applications where the load remains relatively constant.

Other options available upon request.

## Performance Data

### Ratings and Specifications

Figures based on: Oil Temp = 40°C Viscosity = 32 cSt (150 SUS)

Rated flow	140 L/min (37 USgpm)
Max relief setting	420 bar (6090 psi)
Max Load Induced pressure:	340 bar (4930 psi)
Cartridge material	Working parts hardened and ground steel. External steel surfaces zinc plated.
Mounting position	Unrestricted
Cavity number	A20094-T17A
Torque cartridge into cavity	150 Nm (110 lbs ft)
Weight	1.2 kg (2.5 lbs)
Seal kit number	SK1116 (Nitrile) SK1116V (Viton®)
Recommended filtration level	BS5540/4 Class 18/13 (25 micron nominal)
Operation temperature	-30°C to +90°C (-22° to +194°F)
Leakage	0.3 milliliters/min nominal (5 dpm)
Nominal viscosity range	5 to 500 cSt

Viton is a registered trademark of E.I. DuPont

## Description

The 1SER series overcenter valve performs all duties of a regular overcenter but is able to relieve and stay open irrespective of downstream pressure. This enables the valve to operate when used with a closed center directional valve which has service line reliefs. The poppet is pressure balanced, preventing relief setting increase due to back pressure.

## Pressure Drop

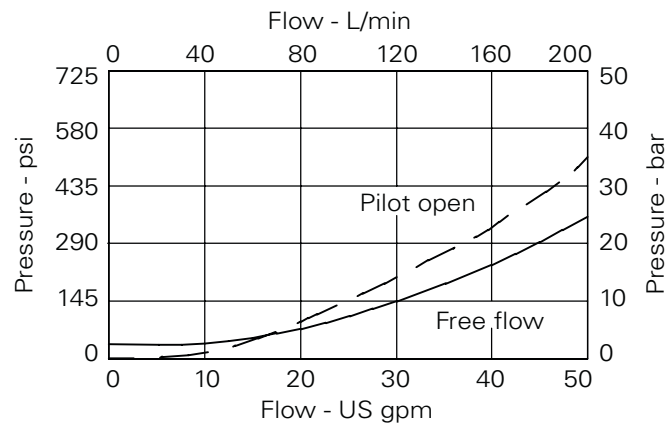

Where measurements are critical request certified drawings. We reserve the right to change specifications without notice.

# 1SER140 - Overcenter Valve

Part balanced pilot assisted relief with check  
 140 L/min (37 USgpm) • 340 bar (4930 psi)

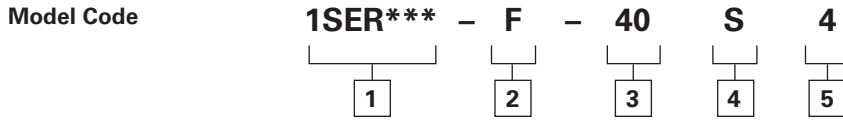

**1 Function**  
**1SER140**

**2 Adjustment Means**  
**F** - Screw Adjustment  
**N** - Fixed - State pressure setting required  
 For fixed versions add setting in 10 bar increments to end of part number. Subject to a ±10% tolerance.

**3 Pressure Range @ 4.8 L/min**  
**Note:** Code based on pressure in bar.  
**20** - 140-250 bar.  
          Std setting 190 bar  
**30** - 220-330 bar.  
          Std setting 270 bar  
**40** - 310-420 bar.  
          Std setting 370 bar  
          Std setting made at 4.8 L/min

**4 Seals**  
**S** - Nitrile (For use with most industrial hydraulic oils)  
**SV** - Viton (For high temperature and most special fluid applications)

**5 Pilot Ratio**  
**4** - 4:1  
**6** - 6:1  
 Other ratios available upon request

## Dimensions

mm (inch)

### Cartridge Only

Basic Code  
 1SER140

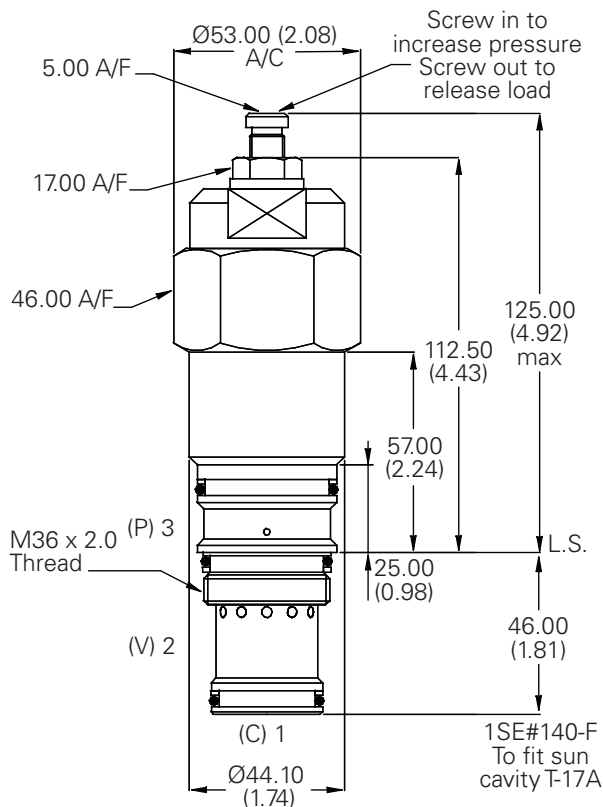

**Note:** Tightening torque of "F" adjuster locknut - 20 to 25 Nm

### Cavity

Model                      A20094-T17A  
 Form Drill                TD-17A  
 Form Reamer            TR17A

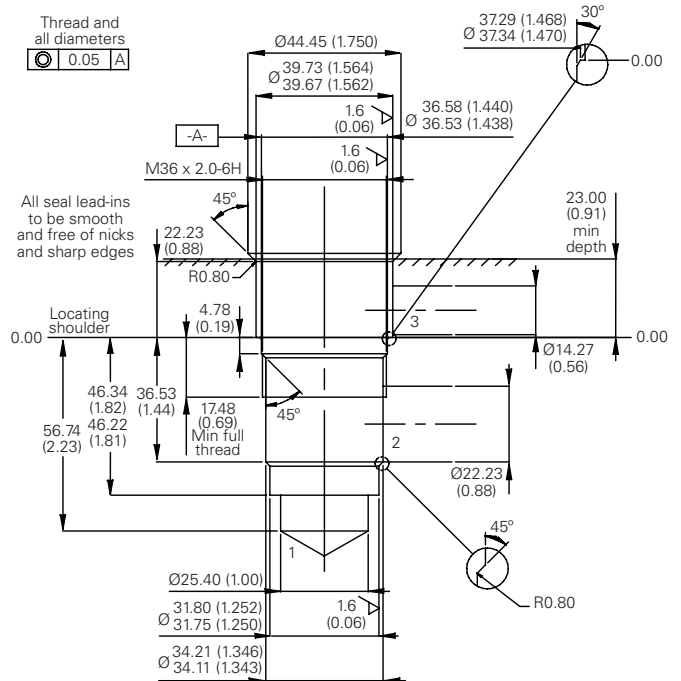

Where measurements are critical request certified drawings. We reserve the right to change specifications without notice.

# ISEL140 - Overcenter Valve

Counterbalanced pilot assisted relief with check

140 L/min (37 USgpm) • 380 bar (5310 psi)

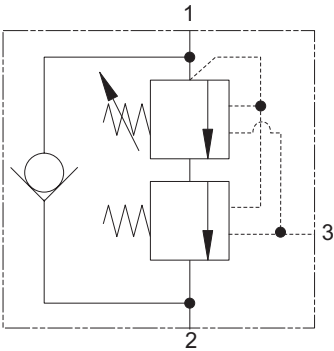

## Operation

The check section allows free flow and then locks the load against movement. The pilot assisted relief valve section will give controlled movement when pilot pressure is applied, maintaining a counterbalance pressure to prevent initial

pressure loss and therefore instability. The total pressure setting will normally be set at 1.3 times the load induced pressure. The counterbalance pressure reduces as the pilot pressure increases.

## Features

Cartridge is economical and fits simple cavity. Allows quick, easy field service - reduces down time. Interchangeable with pilot check valve of a similar size.

## Pilot Ratio

Primary 6.1:1

Secondary 0.5:1

## Sectional View

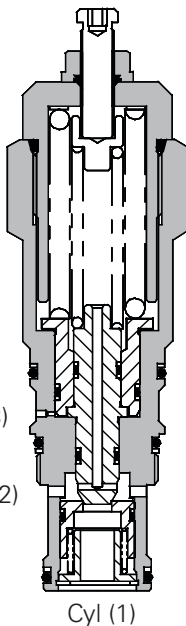

## Performance Data

### Ratings and Specifications

Figures based on: Oil Temp = 40°C Viscosity = 32 cSt (150 SUS)

Rated flow	140 L/min (37 USgpm)
Max setting	380 bar (5310 psi)
Cartridge material	Working parts hardened and ground steel. External steel surfaces zinc plated.
Mounting position	Unrestricted
Cavity number	A20094-T17A
Torque cartridge into cavity	150 Nm (110 lbs ft)
Weight	1.2 kg (2.5 lbs)
Seal kit number	SK1116 (Nitrile) SK1116V (Viton®)
Recommended filtration level	BS5540/4 Class 18/13 (25 micron nominal)
Operation temperature	-30° to +90°C (-22° to +194°F)
Leakage	0.3 milliliters/min nominal (5 dpm)
Nominal viscosity range	5 to 500 cSt

F

## Description

The ISEL overcenter valve performs all duties of a regular overcenter but maintains a counterbalance pressure to provide dampening of cylinders when there is a rapid loss in stored pressure. This counterbalance pressure reduces as the pilot pressure increases. Typical applications include extension cylinders on telescopic handlers where it is important to have a smooth operation when retracting from full extension.

## Pressure Drop

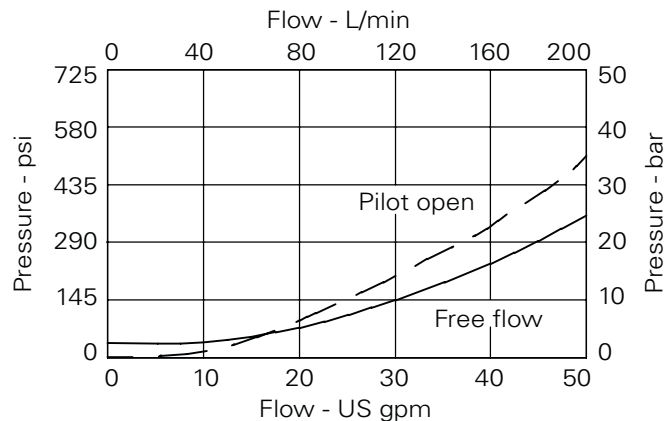

**Note:** This valve has been designed to eliminate instability from flexible boom applications or where the load induced pressure varies greatly. To get the best results, the settings should be adjusted for each application and then factory set for production quantities. Please contact our Technical Department for more information.

Where measurements are critical request certified drawings. We reserve the right to change specifications without notice.

# ISEL140 - Overcenter Valve

Counterbalanced pilot assisted relief with check  
 140 L/min (37 USgpm) • 380 bar (5310 psi)

Model Code

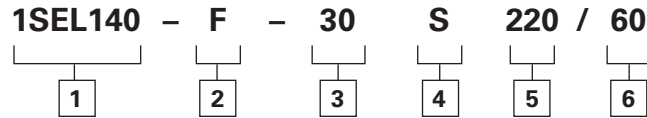

## 1 Basic Code

**1SEL140** - Cartridge and body

## 2 Adjustment Means Counterbalance Setting

**F** - Screw Adjustment  
**N** - Fixed - State pressure setting required

For fixed versions add setting in 10 bar increments to end of part number. Subject to a ±10% tolerance.

## 3 Pressure Range 4.8 L/min

**Note:** Code based on pressure in bar.

- 20** - 170-320 bar.  
Std setting 220 bar (160/60)
- 30** - 230-380 bar.  
Std setting 280 bar (220/60)
- 40** - 310-380 bar.  
Std setting 350 bar (290/60)

## 4 Seals

- S** - Nitrile (For use with most industrial hydraulic oils)
- SV** - Viton (For high temperature and most special fluid applications)

## 5 High Pressure Setting Bar

(10 bar increments).  
 150 to 350 bar (2175 to 5000 psi)

## 6 Counterbalance Setting Bar

(10 bar increments).  
 20 to 100 bar (300 to 1500 psi)

## Dimensions

mm (inch)

### Cartridge Only

Basic Code  
 1SEL140

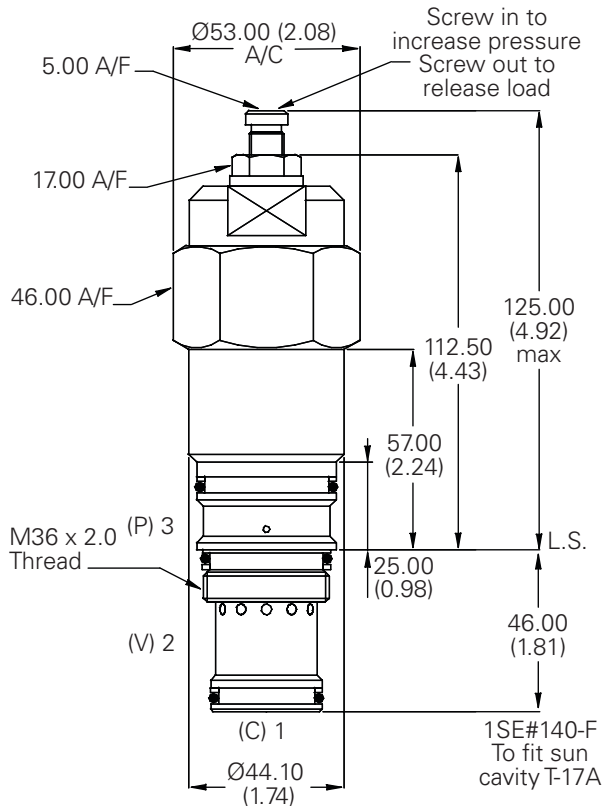

### Cavity

Model A20094-T17A  
 Form Drill TD-17A  
 Form Reamer TR17A

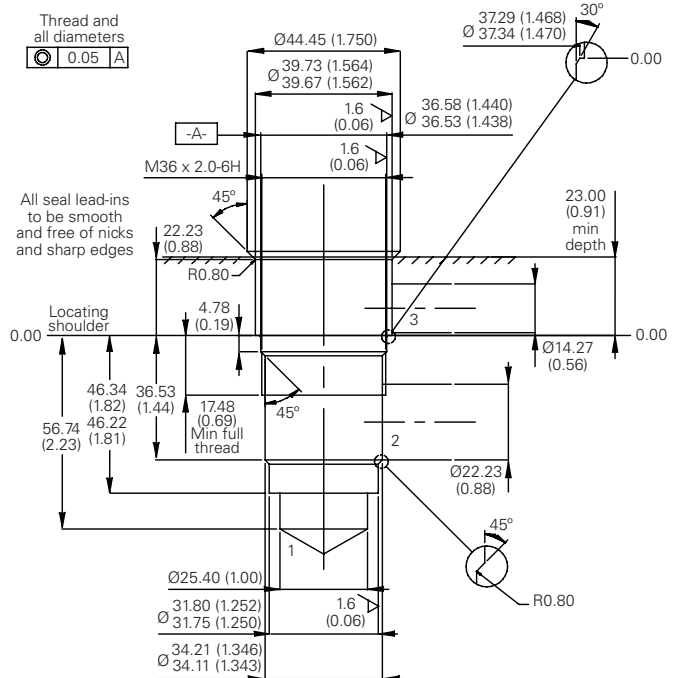

**Note:** Tightening torque of "F" adjuster locknut - 20 to 25 Nm

Where measurements are critical request certified drawings. We reserve the right to change specifications without notice.



# ICEESH35 - Dual Overcenter Valve

Pilot assisted relief with brake shuffle  
 30 L/min (8 USgpm) • 270 bar (4000 psi)

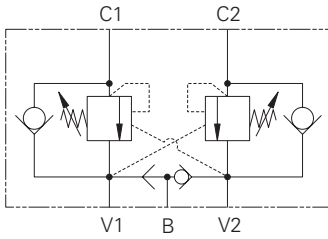

## Operation

The check section allows free flow into the actuator then holds and locks the load against movement. The pilot assisted relief valve section will give controlled movement when pilot pressure is applied. The relief section is normally set to open at a pressure at least 1.3 times the maximum load induced pressure but the pressure required to open the valve and allow movement

depends on the pilot ratio of the valve. For optimization of load control and energy usage, a choice of pilot ratios is available.

The pressure required to open the valve and start actuator movement can be calculated as follows:

$$\text{Pilot Pressure} = \frac{(\text{Relief Setting}) - (\text{Load Pressure})}{\text{Pilot Ratio}}$$

## Features

These valves have the excellent load control and safety features of the dual overcenter valve with the addition of a port for a brake release line. Smooth, safe performance.

## Pilot Ratio

2.5:1 Best suited for extremely unstable applications such as long booms or flexible frameworks.

5.1 (standard) Best suited for applications where load varies and machine structure can induce instability.

10:1 Best suited for applications where the load remains relatively constant.

F

## Description

Overcenter Valves give static and dynamic control of loads by regulating the flow into and out of hydraulic actuators. When installed close to or within an actuator, the overcenter valve will stop runaway in the event of hose burst and if open centre directional control valves are used, will allow thermal expansion relief of the hydraulic fluid.

These dual overcenter valves also contain a brake release shuttle valve which ensures that pressure is applied to a brake release circuit regardless of whether pressure is applied to ports V1 or V2. These multifunction valves are normally used for the static and dynamic control of systems using motors or semi-rotary actuators.

## Performance Data

### Ratings and Specifications

Figures based on: Oil Temp = 40°C Viscosity = 32 cSt (150 SUS)

Rated flow	30 L/min (8 USgpm)
Max relief pressure	350 bar (5000 psi)
Max load induced pressure	270 bar (4000 psi)
Cartridge material	Working parts hardened and ground steel. External surfaces electroless nickel plated.
Standard housing material	Steel
Mounting position	Line Mounted
Weight	2.20 kg (4.84 lbs)
Seal kit	SK816 (Nitrile) SK816V (Viton®)
Filtration	BS5540/4 Class 18/13 (25 micron nominal)
Temperature range	-30° to +90°C (-22° to +194°F)
Internal leakage	0.3 milliliters/min nominal (5 dpm)
Nominal viscosity range	5 to 500 cSt

Viton is a registered trademark of E.I. DuPont

## Pressure Drop

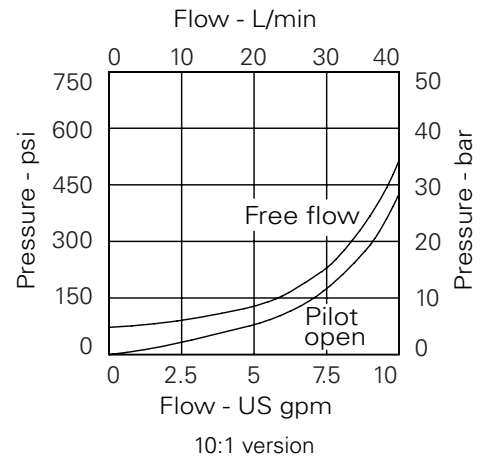
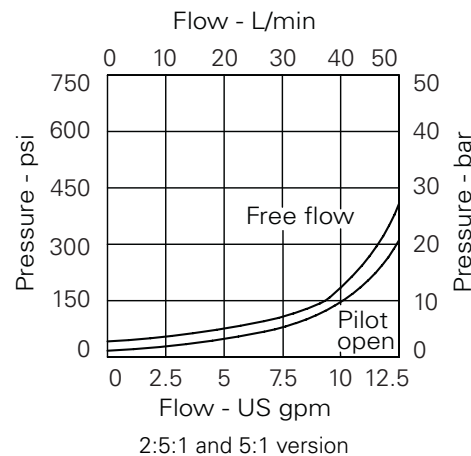

Where measurements are critical request certified drawings. We reserve the right to change specifications without notice.

# 1CEESH35 - Dual Overcenter Valve

Pilot assisted relief with brake shuffle

30 L/min (8 USgpm) • 270 bar (4000 psi)

## Model Code

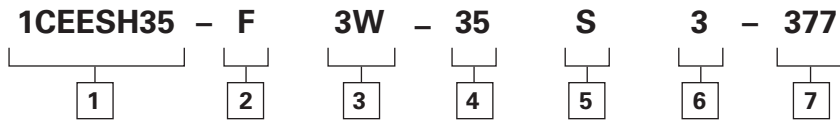

### 1 Basic Code

**1CEESH35** - Cartridge and Body

### 2 Adjustment

**F** - Screw adjustment  
**N** - Fixed - State pressure setting required

For fixed versions add setting in 10 bar increments to end of part number. Subject to a ±10% tolerance.

### 3 Port Size

**Code Port Size**

**3W** 3/4" BSP Valve & Cyl Port 1/4" BSP Brake Port

### 4 Pressure Range @ 4.8 L/min

**Note:** Code based on pressure in bar.

**35** - (2.5:1 and 5:1) 100-350 bar.  
 Std setting 210 bar  
 (10:1) 120-350 bar.

Std setting made at 4.8 L/min

### 5 Seal Material

**S** - Nitrile (For use with most industrial hydraulic oils)  
**SV** - Viton (For high temperature and most special fluid applications)

**Housing Number - Sub Assembly**

**Steel Single**

**BXP15939-3W-S-377**

### 6 Pilot Ratio

**2** - 2.5:1  
**5** - 5:1 (Standard)  
**10** - 10:1

### 7 Body Material

**377** - Steel

## Dimensions

mm (inch)

### Complete Valve

3/8" Ports

Basic Code

1CEESH35

Internally Cross Piloted

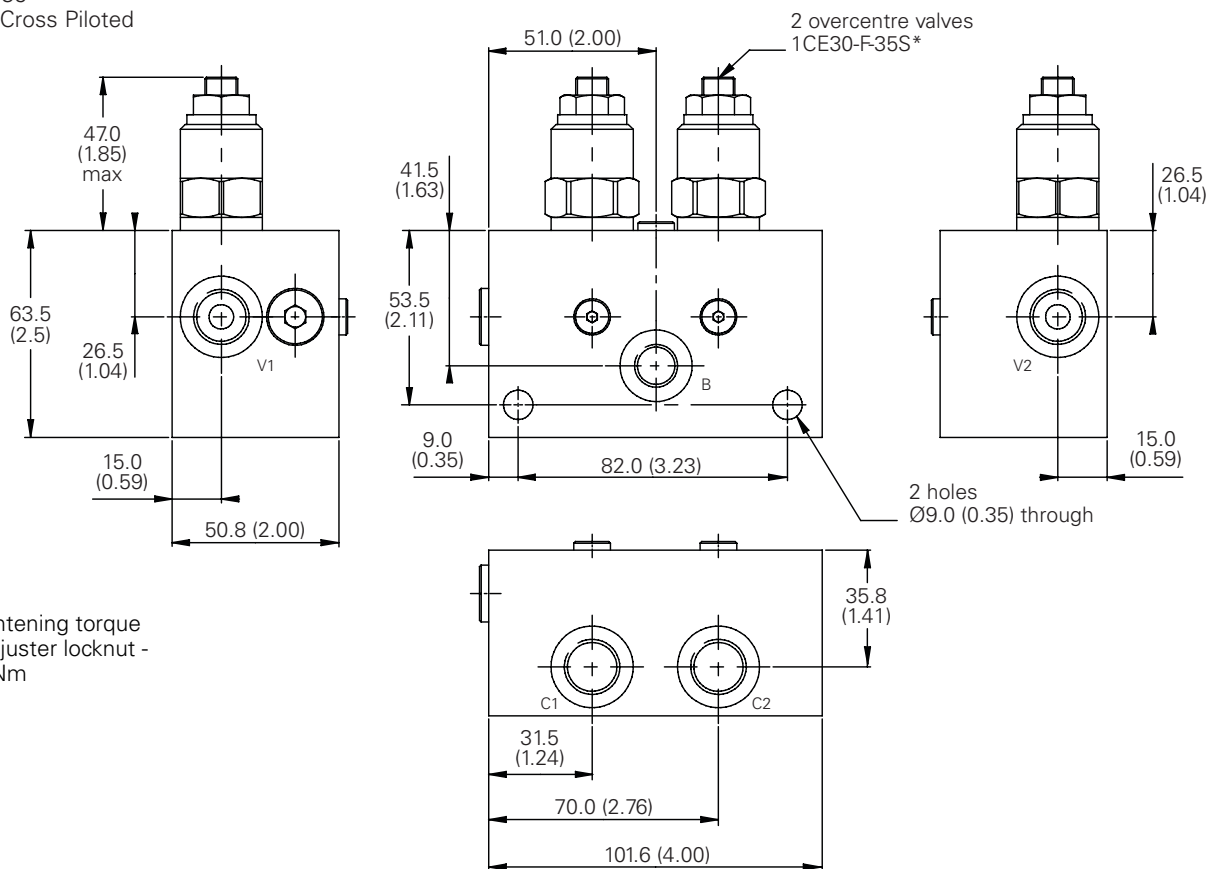

**Note:** Tightening torque of "F" adjuster locknut - 20 to 25 Nm

Where measurements are critical request certified drawings. We reserve the right to change specifications without notice.

# ICEESH95 - Dual Overcenter Valve

Pilot assisted relief with brake shuffle  
 90 L/min (23 USgpm) • 270 bar (4000 psi)

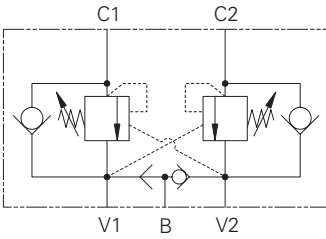

## Operation

The check section allows free flow into the actuator then holds and locks the load against movement. The pilot assisted relief valve section will give controlled movement when pilot pressure is applied. The relief section is normally set to open at a pressure at least 1.3 times the maximum load induced pressure but the pressure required to open the valve and allow movement

depends on the pilot ratio of the valve. For optimization of load control and energy usage, a choice of pilot ratios is available.

The pressure required to open the valve and start actuator movement can be calculated as follows:

$$\text{Pilot Pressure} = \frac{(\text{Relief Setting}) - (\text{Load Pressure})}{\text{Pilot Ratio}}$$

## Features

These valves have the excellent load control and safety features of the dual overcenter valve with the addition of a port for a brake release line. Smooth, safe performance.

## Pilot Ratio

4:1 Best suited for applications where load varies and machine structure can induce instability.

8:1 Best suited for applications where the load remains relatively constant.

Other ratios are available upon request.

## Description

Overcenter Valves give static and dynamic control of loads by regulating the flow into and out of hydraulic actuators. When installed close to or within an actuator, the overcenter valve will stop runaway in the event of hose burst and if open center directional control valves are used, will allow thermal expansion relief of the hydraulic fluid.

These dual overcenter valves also contain a brake release shuttle valve which ensures that pressure is applied to a brake release circuit regardless of whether pressure is applied to ports V1 or V2. These multifunction valves are normally used for the static and dynamic control of systems using motors or semi-rotary actuators.

## Performance Data

### Ratings and Specifications

Figures based on: Oil Temp = 40°C Viscosity = 32 cSt (150 SUS)

Rated flow	30 L/min (8 USgpm)
Max relief pressure	350 bar (5000 psi) <b>(35)</b> , 225 bar (3260 psi) <b>(20)</b>
Max load induced pressure	270 bar (4000 psi), 160 bar (2300 psi)
Cartridge material	Working parts hardened and ground steel. External surfaces electroless nickel plated.
Standard housing material	Steel
Mounting position	Line Mounted
Weight	2.20 kg (4.84 lbs)
Seal kit	SK817 (Nitrile) SK817V (Viton®)
Filtration	BS5540/4 Class 18/13 (25 micron nominal)
Temperature range	-30°C to +90°C (-22° to +194°F)
Internal leakage	0.3 milliliters/min nominal (5 dpm)
Nominal viscosity range	5 to 500 cSt

Viton is a registered trademark of E.I. DuPont

## Pressure Drop

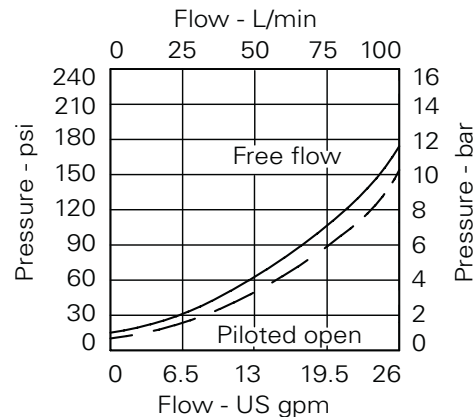

4:1 version

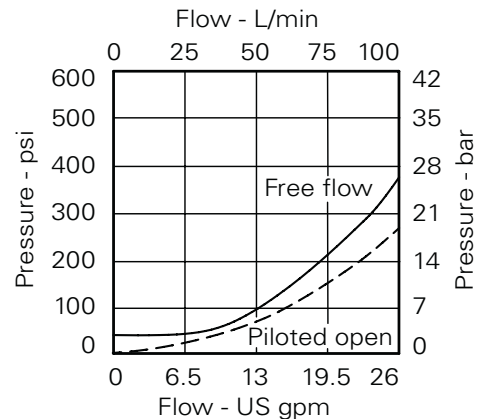

8:1 version

Where measurements are critical request certified drawings. We reserve the right to change specifications without notice.

# 1CEESH95 - Dual Overcenter Valve

Pilot assisted relief with brake shuffle

90 L/min (23 USgpm) • 270 bar (4000 psi)

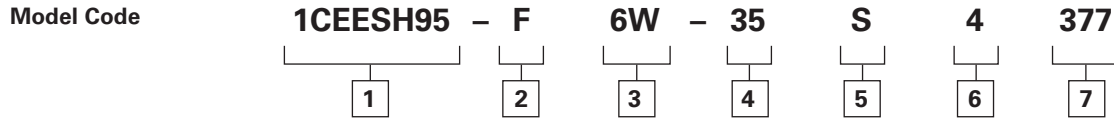

**1 Function**  
**1CEESH95** - Cartridge and Body

**2 Adjustment Means**  
**F** - Screw adjustment  
**N** - State pressure setting required  
 For fixed versions add setting in 10 bar increments to end of part number. Subject to a ±10% tolerance.

**3 Port Size**

Code	Port Size	Housing Number - Body Only
<b>Steel</b>		
<b>6W</b>	3/4" BSP Valve & Cyl Port 1/4" BSP Brake Port	BXP17429-6W-S-377

**4 Pressure Range**  
**4.8 L/min**  
**Note:** Code based on pressure in bar.  
**20** - 70-225 bar.  
       Std setting 100 bar  
**35** - 200-350 bar.  
       Std setting 210 bar  
       Std setting made at 4.8 L/min

**5 Seals**  
**S** - Nitrile (For use with most industrial hydraulic oils.  
**SV** - Viton (For high temperature and most special fluid applications)

**6 Pilot Ratio**  
**4** - 4:1  
**8** - 8:1

**7 Body Material**  
**377** - Steel

**Dimensions**  
 mm (inch)

**Complete Valve**  
 3/4" Ports  
 Basic Code  
**1CEESH95**

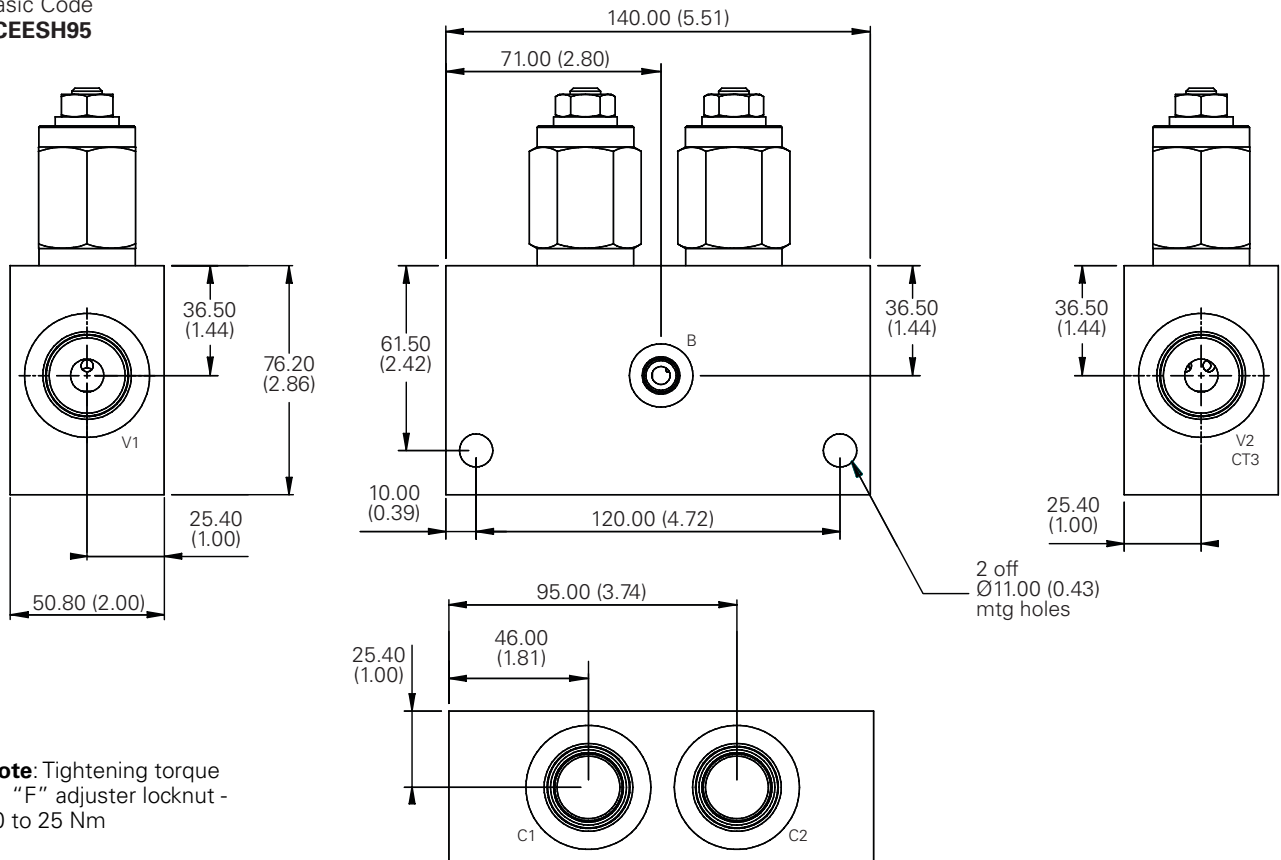

**Note:** Tightening torque of "F" adjuster locknut - 20 to 25 Nm

Where measurements are critical request certified drawings. We reserve the right to change specifications without notice.



# ICEESH150 - Dual Overcenter Valve

Pilot assisted relief with brake shuttle

150 L/min (40 USgpm) • 270 bar (4000 psi)

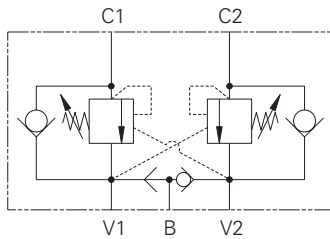

## Operation

The check section allows free flow into the actuator then holds and locks the load against movement. The pilot assisted relief valve section will give controlled movement when pilot pressure is applied. The relief section is normally set to open at a pressure at least 1.3 times the maximum load induced pressure but the pressure required to open the valve and allow movement

depends on the pilot ratio of the valve. For optimization of load control and energy usage, a choice of pilot ratios is available.

The pressure required to open the valve and start actuator movement can be calculated as follows:

$$\text{Pilot Pressure} = \frac{(\text{Relief Setting}) - (\text{Load Pressure})}{\text{Pilot Ratio}}$$

## Features

These valves have the excellent load control and safety features of the dual overcenter valve with the addition of a port for a brake release line. Smooth, safe performance.

## Pilot Ratio

3.5:1 Best suited for applications where load varies and machine structure can induce instability.

## Description

Overcenter Valves give static and dynamic control of loads by regulating the flow into and out of hydraulic actuators. When installed close to or within an actuator, the overcenter valve will stop runaway in the event of hose burst and if open center directional control valves are used, will allow thermal expansion relief of the hydraulic fluid.

These dual overcenter valves also contain a brake release shuttle valve which ensures that pressure is applied to a brake release circuit regardless of whether pressure is applied to ports V1 or V2. These multifunction valves are normally used for the static and dynamic control of systems using motors or semi-rotary actuators.

## Performance Data

### Ratings and Specifications

Figures based on: Oil Temp = 40°C Viscosity = 32 cSt (150 SUS)

Rated flow	150 L/min (40 USgpm)
Max relief pressure	350 bar (5000 psi)
Max load induced pressure	270 bar (4000 psi)
Cartridge material	Working parts hardened and ground steel. External surfaces electroless nickel plated.
Standard housing material	Steel
Mounting position	Line Mounted
Weight	3.50 kg (7.70 lbs)
Seal kit	SK818 (Nitrile) SK818V (Viton®)
Filtration	BS5540/4 Class 18/13 (25 micron nominal)
Temperature range	-30° to +90°C (-22° to +194°F)
Internal leakage	0.3 milliliters/min nominal (5 dpm)
Nominal viscosity range	5 to 500 cSt

Viton is a registered trademark of E.I. DuPont

## Pressure Drop

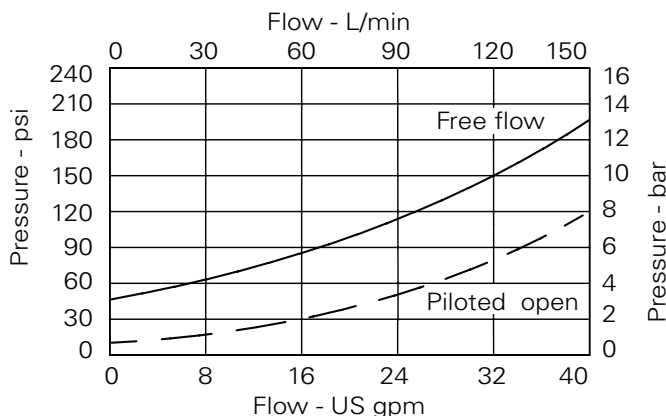

Where measurements are critical request certified drawings. We reserve the right to change specifications without notice.

# 1CEESH150 - Dual Overcenter Valve

Pilot assisted relief with brake shuttle

150 L/min (40 USgpm) • 270 bar (4000 psi)

Model Code

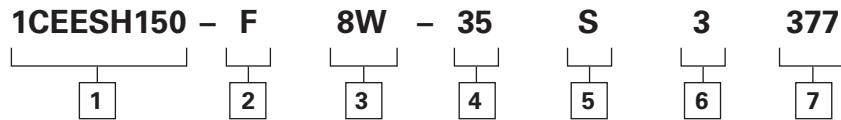

## 1 Function

**1CEESH150** - Cartridges and Body

## 2 Adjustment Means

F - Screw adjustment

## 3 Port Size

Code	Port Size	Housing Number - Body Only
<b>Steel</b>		
<b>8W</b>	1" BSP Valve & Cyl Port 1/4" BSP Pilot Port	CXP15933-8W-377

## 4 Pressure Range @ 4.8 L/min

**Note:** Code based on pressure in bar.

**35** - 70-350 bar.  
Std setting 210 bar  
Std setting made at 4.8 L/min

## 5 Seal Material

**S** - Nitrile (For use with most industrial hydraulic oils.)  
**SV** - Viton (For high temperature and most special fluid applications)

## 6 Pilot Ratio

**3** - 3.5:1

## 7 Body Material

**377** - Steel

## Dimensions

mm (inch)

## Complete Valve

1" Ports

Basic Code

1CEESH150

Internally Cross Piloted

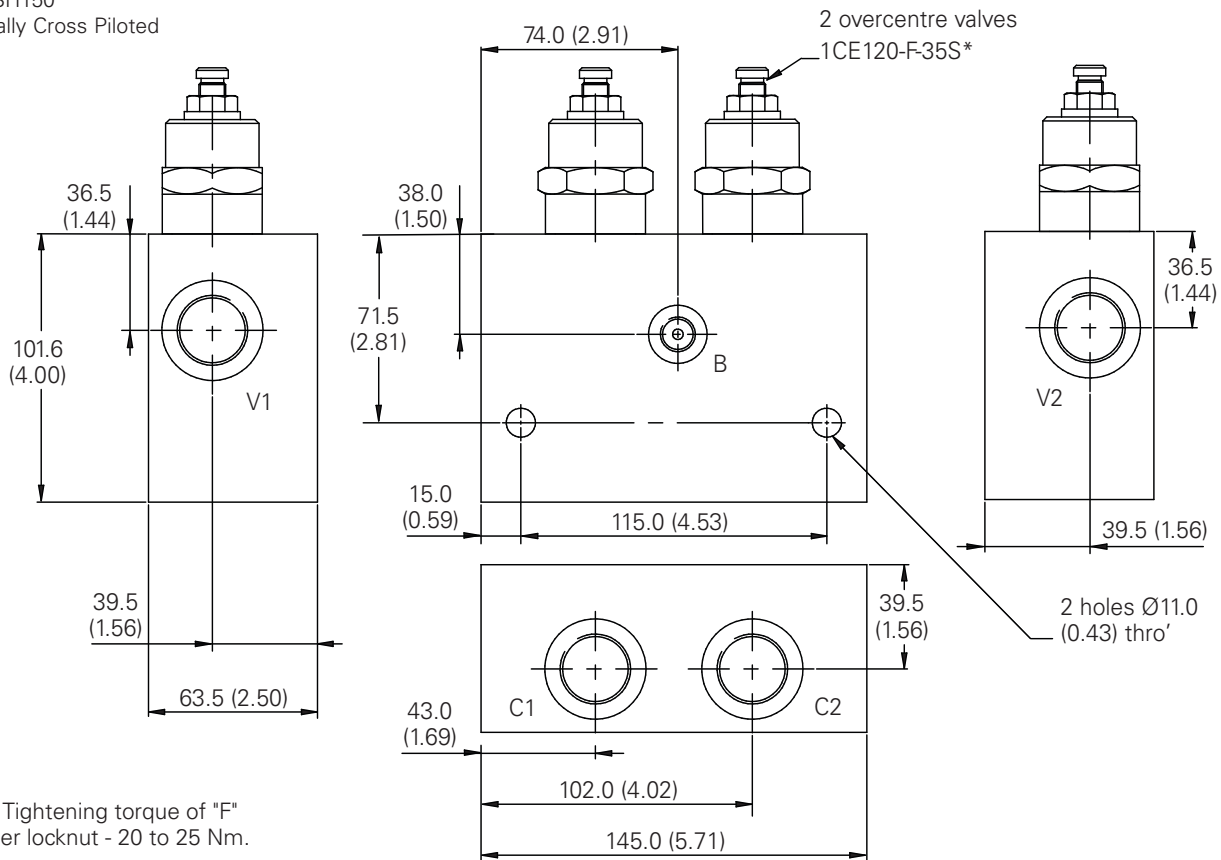

**Note:** Tightening torque of "F" adjuster locknut - 20 to 25 Nm.

Where measurements are critical request certified drawings. We reserve the right to change specifications without notice.

# ICEESH350 - Dual Overcenter Valve

Pilot assisted relief with brake shuttle

300 L/min (80 USgpm) • 270 bar (4000 psi)

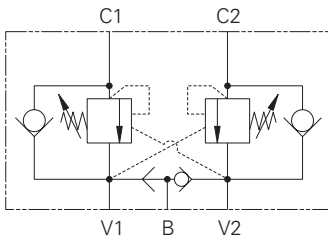

## Operation

The check section allows free flow into the actuator then holds and locks the load against movement. The pilot assisted relief valve section will give controlled movement when pilot pressure is applied. The relief section is normally set to open at a pressure at least 1.3 times the maximum load induced pressure but the pressure required to open the

valve and allow movement depends on the pilot ratio of the valve. For optimization of load control and energy usage, a choice of pilot ratios is available.

The pressure required to open the valve and start actuator movement can be calculated as follows:

$$\text{Pilot Pressure} = \frac{(\text{Relief Setting}) - (\text{Load Pressure})}{\text{Pilot Ratio}}$$

## Features

These valves have the excellent load control and safety features of the dual overcenter valve with the addition of a port for a brake release line. Smooth, safe performance.

## Pilot Ratio

3:1 Best suited for applications where load varies and machine structure can induce instability.

8:1 Best suited for applications where the load remains relatively constant.

## Description

Overcenter Valves give static and dynamic control of loads by regulating the flow into and out of hydraulic actuators. When installed close to or within an actuator, the overcenter valve will stop runaway in the event of hose burst and if open center directional control valves are used, will allow thermal expansion relief of the hydraulic fluid.

These dual overcenter valves also contain a brake release shuttle valve which ensures that pressure is applied to a brake release circuit regardless of whether pressure is applied to ports V1 or V2. These multifunction valves are normally used for the static and dynamic control of systems using motors or semi-rotary actuators.

## Performance Data

### Ratings and Specifications

Figures based on: Oil Temp = 40°C Viscosity = 32 cSt (150 SUS)

Rated flow	300 L/min (80 USgpm)
Max relief pressure	350 bar (5000 psi)
Max load induced pressure	270 bar (4000 psi)
Cartridge material	Working parts hardened and ground steel. External surfaces electroless nickel plated.
Standard housing material	Steel
Mounting position	Line mounted
Weight	5.42 kg (11.94 lbs)
Seal kit	SK688 (Nitrile) SK688V (Viton®)
Filtration	BS5540/4 Class 18/13 (25 micron nominal)
Temperature range	-30°C to +90°C (-22° to +194°F)
Internal leakage	4 milliliters/min nominal (60 dpm)
Nominal viscosity range	5 to 500 cSt

Viton is a registered trademark of E.I. DuPont

## Pressure Drop

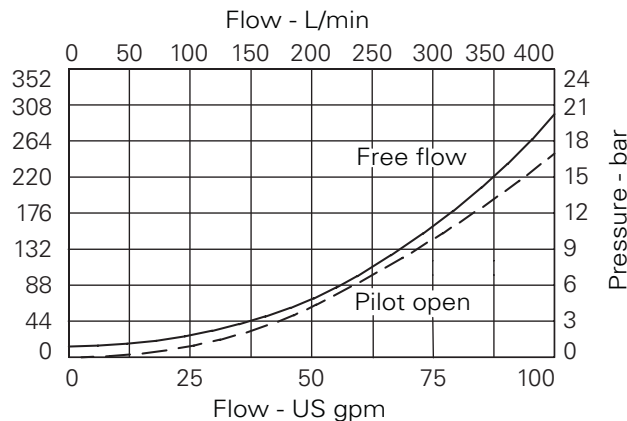

Where measurements are critical request certified drawings. We reserve the right to change specifications without notice.

# ICEESH350 - Dual Overcenter Valve

Pilot assisted relief with brake shuttle  
 300 L/min (80 USgpm) • 270 bar (4000 psi)

<b>Model Code</b>	<b>1CEESH350</b>	<b>- F</b>	<b>10W</b>	<b>- 35</b>	<b>S</b>	<b>3</b>	<b>377</b>
	1	2	3	4	5	6	7

## 1 Basic Code

**1CEESH350** - Cartridges and Body

## 3 Port Size

Code	Port Size	Housing Number - Body Only
<b>Steel</b>		
<b>10W</b>	1 1/4" BSP Valve & Cyl Port 1/4" BSP Pilot Port	CXP22297-10W-S-377

## 2 Adjustment Means

**F** - Screw adjustment

## 4 Pressure Range @ 4.8 L/min

**Note:** Code based on pressure in bar.

**35** - 70-350 bar.  
 Std setting 210 bar  
 Std setting made at 4.8 L/min

## 5 Seals

**S** - Nitrile (For use with most industrial hydraulic oils.)  
**SV** - Viton (For high temperature and most special fluid applications)

## 6 Pilot Ratio

**3** - 3:1  
**8** - 8:1

## 7 Body Material

**377** - Steel

## Dimensions

mm (inch)

## Complete Valve

1 1/4" Ports  
 Basic Code  
 1CEESH350  
 Internally Cross Piloted

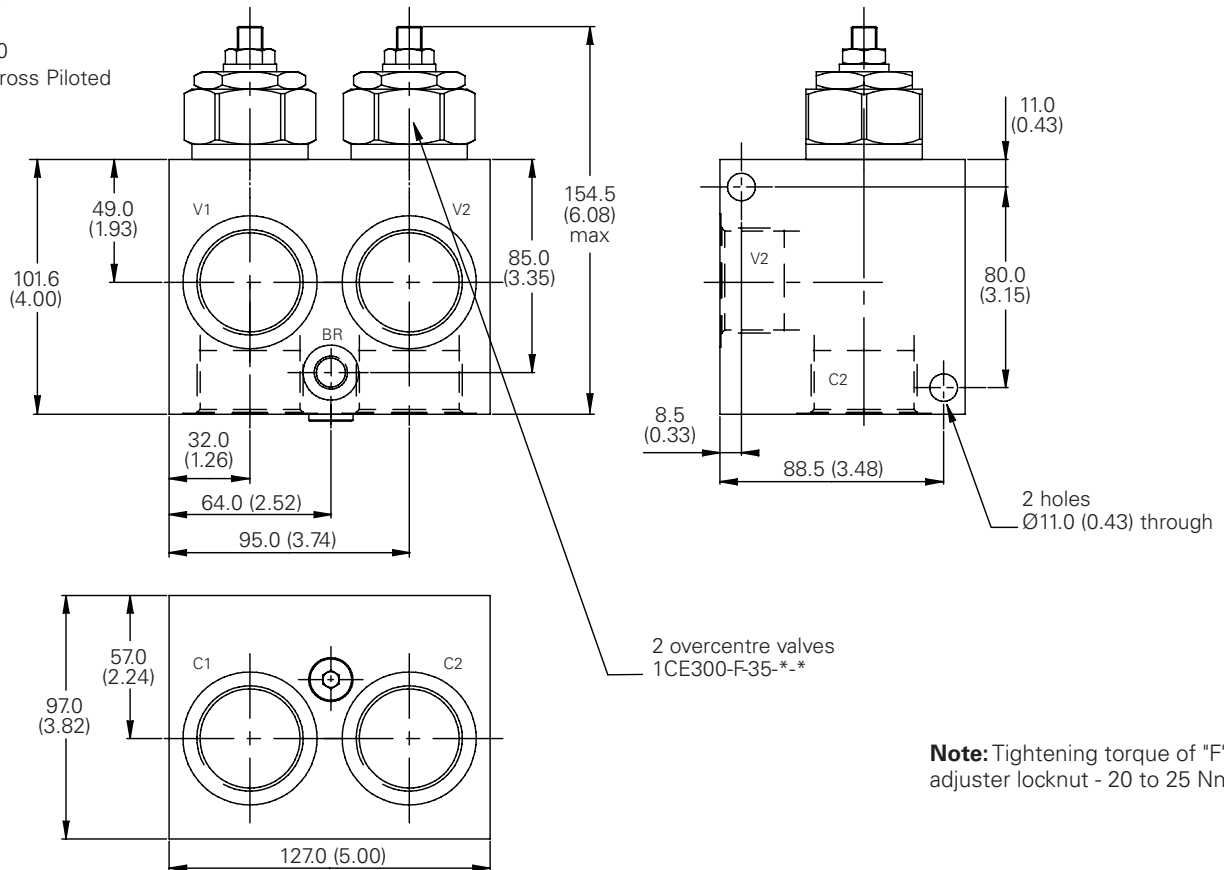

**Note:** Tightening torque of "F" adjuster locknut - 20 to 25 Nm.

Where measurements are critical request certified drawings. We reserve the right to change specifications without notice.

# ICEEC35 - Motion Control and Lock Valve

Pilot assisted relief

30 L/min (8 USgpm) • 270 bar (4000 psi)

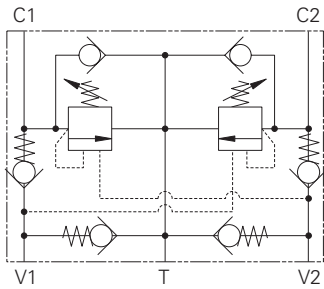

## Operation

The check section allows free flow into the actuator then holds and locks the load against movement. The pilot assisted relief valve section will give controlled movement when pilot pressure is applied. The relief section is normally set to open at a pressure at least 1.3 times the maximum load induced pressure but the pressure required to open the valve and allow movement depends on the pilot ratio of the valve. For optimization of load control and energy

usage, a choice of pilot ratios is available.

The pressure required to open the valve and start actuator movement can be calculated as follows:

$$\text{Pilot Pressure} = \frac{(\text{Relief Setting}) - (\text{Load Pressure})}{\text{Pilot Ratio}}$$

A system of check valves allows crossline relief for dynamic applications with the optional make up facility to compensate for any change in system volume.

## Features

These valves provide complete circuit control and protection in a single valve body, reducing installation time and cost. Smooth, safe performance of dual direction actuators.

## Pilot Ratio

2.5:1 Best suited for extremely unstable applications such as long booms or flexible frameworks.

5:1 (standard) Best suited for applications where the load varies and machine structure can induce instability.

10:1 Best suited for applications where the load remains relatively constant.

F

## Description

Motion control and lock valves give static and dynamic control by regulating the flow into and out of hydraulic actuators. When installed close to an actuator, the valve can stop runaway in the event of hose burst. The valves also give dual thermal and overload relief protection.

A low pressure tank or charge line may be connected to the T port to provide a make-up flow to either actuator port.

## Performance Data

### Ratings and Specifications

Figures based on: Oil Temp = 40°C Viscosity = 32 cSt (150 SUS)

Rated flow	30 L/min (8 USgpm)
Max relief pressure	350 bar (5000 psi) <b>(35)</b> , 225 bar (3260 psi) <b>(20)</b>
Max load induced pressure	270 bar (4000 psi) <b>(35)</b> , 160 bar (2300 psi) <b>(20)</b>
Cartridge material	Working parts hardened and ground steel. External surfaces electroless nickel plated.
Standard housing material	Steel
Mounting position	Line mounted
Weight	2.03 kg (4.50 lbs)
Seal kit	SK815 (Nitrile) SK815V (Viton®)
Filtration	BS5540/4 Class 18/13 (25 micron nominal)
Temperature range	-30° to +90°C (-22° to +194°F)
Internal leakage	0.3 milliliters/min nominal (5 dpm)
Nominal viscosity range	5 to 500 cSt

Viton is a registered trademark of E.I. DuPont

## Pressure Drop

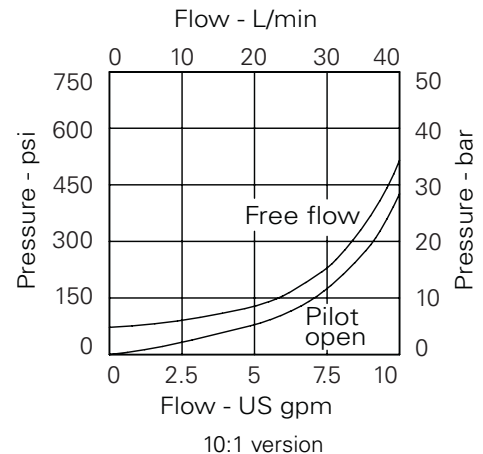
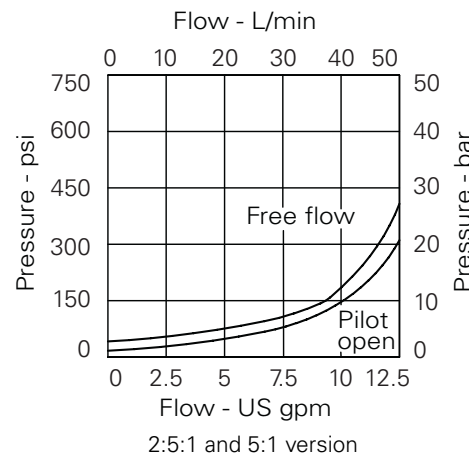

Where measurements are critical request certified drawings. We reserve the right to change specifications without notice.

# 1CEEC35 - Motion Control and Lock Valve

Pilot assisted relief

30 L/min (8 USgpm) • 270 bar (4000 psi)

## Model Code

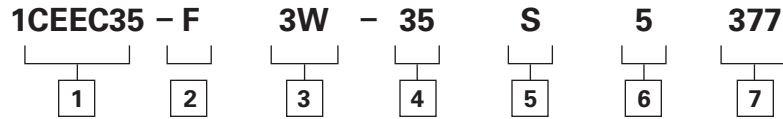

### 1 Basic Code

**1CEEC35** - Cartridge and Body

### 2 Adjustment Means

**F** - Screw adjustment  
**N** - Fixed - State pressure setting required

For fixed versions add setting in 10 bar increments to end of part number. Subject to a ±10% tolerance.

### 3 Port Size - Bodied Valves Only

Code	Port Size	Housing Number
<b>Steel</b>		
<b>3W</b>	<b>3/8" BSP</b>	<b>BXP16247-3W-S-377</b>

### 4 Pressure Range @ 4.8 L/min

**Note:** Code based on pressure in bar.

<b>20</b> - (2.5:1 and 5:1)	70-210 bar	Std setting 100 bar
	(10:1)	100-210 bar
<b>35</b> - (2.5:1 and 5:1)	100-350 bar	Std setting 210 bar
	(10:1)	120-350 bar

Std setting made a 4.8 L/min made at 4.8 L/min

### 5 Seals

**S** - Nitrile (For use with most industrial hydraulic oils.  
**SV** - Viton (For high temperature and most special fluid applications)

### 6 Pilot Ratio

**2** - 2.5:1  
**5** - 5:1  
**10** - 10:1

Other ratios available upon request

### 7 Body Material

**377** - Steel

**F**

## Dimensions

mm (inch)

## Complete Valve

3/8" Ports Ports

Basic Code

**1CEEC35**

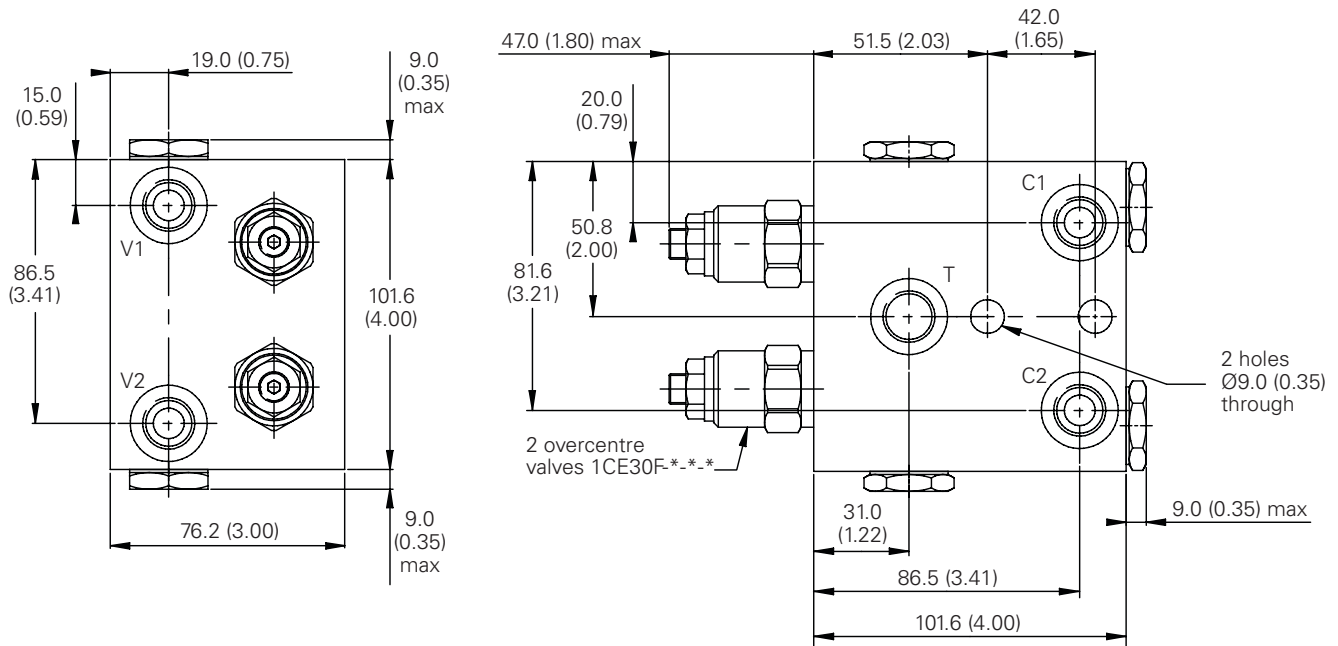

**Note:** Tightening torque of "F" adjuster locknut - 20 to 25 Nm

Where measurements are critical request certified drawings. We reserve the right to change specifications without notice.

# 1CEEC95 - Motion Control & Lock Valve

Pilot assisted relief

95 L/min (25 USgpm) • 270 bar (4000 psi)

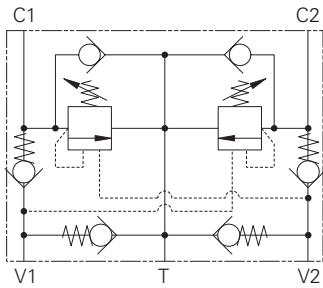

## Operation

The check section allows free flow into the actuator then holds and locks the load against movement. The pilot assisted relief valve section will give controlled movement when pilot pressure is applied. The relief section is normally set to open at a pressure at least 1.3 times the maximum load induced pressure but the pressure required to open the valve and allow movement depends on the pilot ratio of the valve. For optimization of load control and energy

usage, a choice of pilot ratios is available.

The pressure required to open the valve and start actuator movement can be calculated as follow

$$\text{Pilot Pressure} = \frac{(\text{Relief Setting}) - (\text{Load Pressure})}{\text{Pilot Ratio}}$$

A system of check valves allows crossline relief for dynamic applications with the optional make up facility to compensate for any change in system volume.

## Features

These valves provide complete circuit control and protection in a single valve body, reducing installation time and cost. Smooth, safe performance of dual direction actuators.

## Pilot Ratio

4:1 Best suited for applications where the load varies and machine structure can induce instability.

8:1 Best suited for applications where the load remains relatively constant.

## Description

Motion control and lock valves give static and dynamic control by regulating the flow into and out of hydraulic actuators. When installed close to an actuator, the valve can stop runaway in the event of hose burst. The valves also give dual thermal and overload relief protection.

A low pressure tank or charge line may be connected to the T port to provide a make-up flow to either actuator port.

## Performance Data

### Ratings and Specifications

Figures based on: Oil Temp = 40°C Viscosity = 32 cSt (150 SUS)

Rated flow	1CEEC95 95 L/min (25 USgpm)
Max relief pressure	350 bar (5000 psi) <b>(35)</b> , 225 bar (3260 psi) <b>(20)</b>
Max load induced pressure	270 bar (4000 psi) <b>(35)</b> , 160 bar (2300 psi) <b>(20)</b>
Cartridge material	Working parts hardened and ground steel. External surfaces electroless nickel plated.
Standard housing material	Steel
Mounting position	Line mounted
Weight	3.70 kg (8.20 lbs)
Seal kit	SK814 (Nitrile) SK814V (Viton®)
Filtration	BS5540/4 Class 18/13 (25 micron nominal)
Temperature range	-30° to +90°C (-22° to +194°F)
Internal leakage	0.3 milliliters/min nominal (5 dpm)
Nominal viscosity range	5 to 500 cSt

Viton is a registered trademark of E.I. DuPont

## Pressure Drop

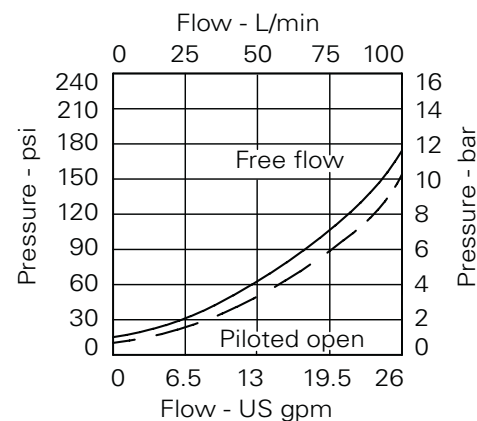

4:1 version

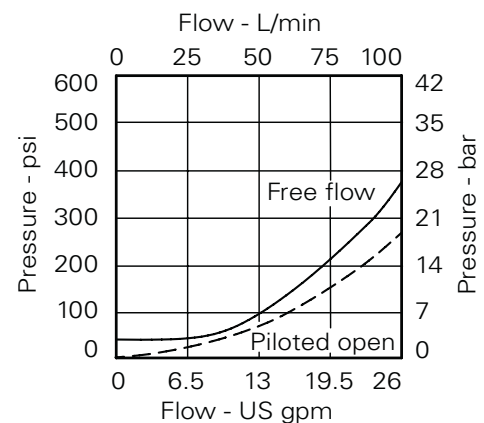

8:1 version

Where measurements are critical request certified drawings. We reserve the right to change specifications without notice.

# 1CEEC95 - Motion Control & Lock Valve

Pilot assisted relief

95 L/min (25 USgpm) • 270 bar (4000 psi)

## Model Code

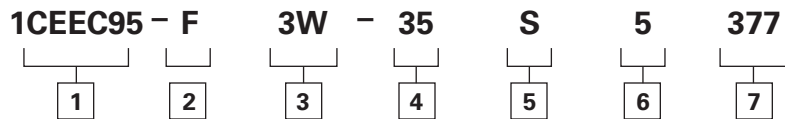

### 1 Basic Code

1CEEC95 - Cartridge and Body

### 2 Adjustment Means

F - Screw adjustment  
N - Fixed - State pressure setting required

For fixed versions add setting in 10 bar increments to end of part number. Subject to a ±10% tolerance.

### 3 Port Size

Code	Port Size	Housing Number - Body Only
6W	3/4" BSP	Steel BXP16248-6W-S-377

### 4 Pressure Range @ 4.8 L/min

Note: Code based on pressure in bar.

35 - (4:1 and 8:1)  
200-350 bar  
Std setting 210 bar  
Std setting made at 4.8 L/min

### 5 Seals

S - Nitrile (For use with most industrial hydraulic oils)  
SV - Viton (For high temperature and most special fluid applications made at 4.8 L/min)

### 6 Pilot Ratio

4 - 4:1  
8 - 8:1  
Other ratios available upon request

### 7 Body Material

377 - Steel

## Dimensions

mm (inch)

### Complete Valve

3/4" Ports  
Basic Code  
1CEEC95  
Internally Cross Piloted

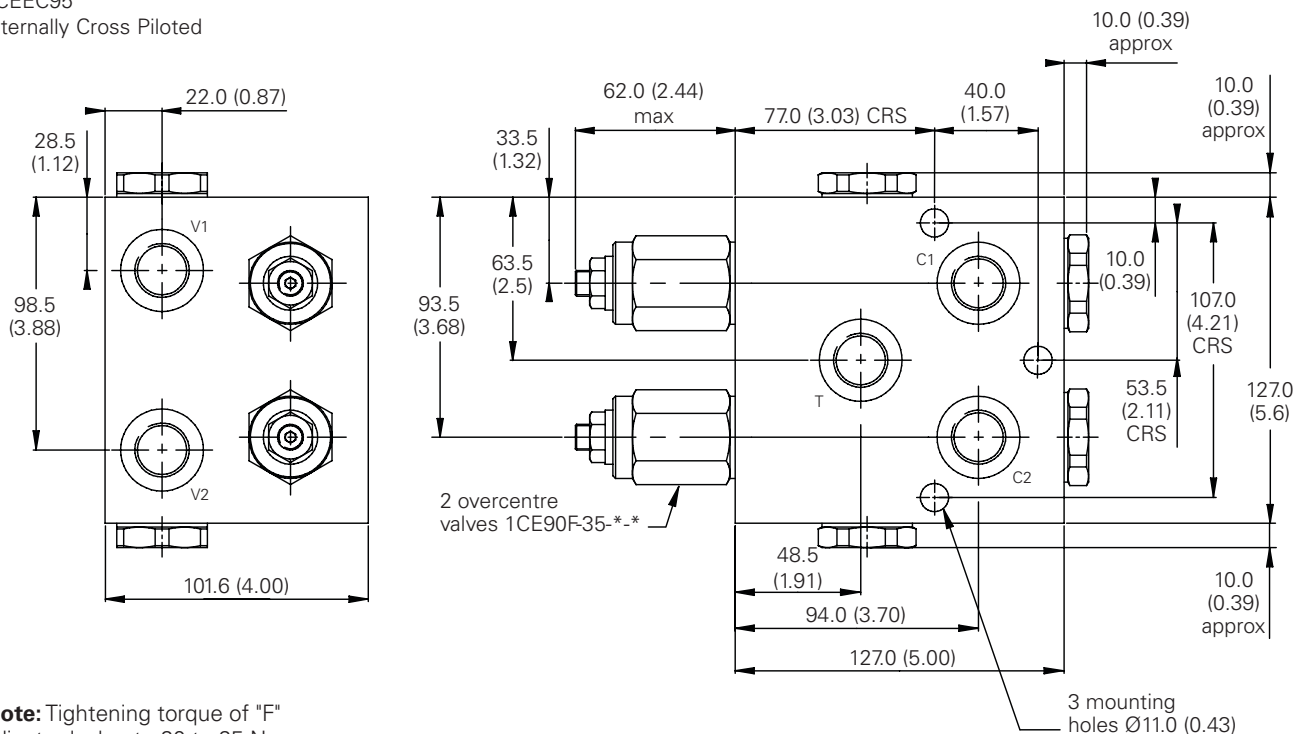

Note: Tightening torque of "F" adjuster locknut - 20 to 25 Nm.

Where measurements are critical request certified drawings. We reserve the right to change specifications without notice.

# ICEEC150 - Motion Control & Lock Valve

Pilot assisted relief

150 L/min (40 USgpm) • 270 bar (4000 psi)

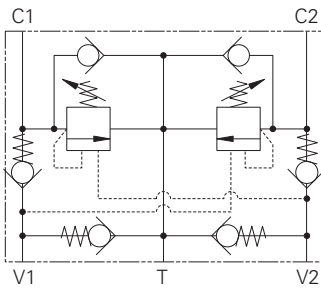

## Operation

The check section allows free flow into the actuator then holds and locks the load against movement. The pilot assisted relief valve section will give controlled movement when pilot pressure is applied. The relief section is normally set to open at a pressure at least 1.3 times the maximum load induced pressure but the pressure required to open the valve and allow movement depends on the pilot ratio of the valve. For optimization of load control and energy

usage, a choice of pilot ratios is available.

The pressure required to open the valve and start actuator movement can be calculated as follows:

$$\text{Pilot Pressure} = \frac{(\text{Relief Setting}) - (\text{Load Pressure})}{\text{Pilot Ratio}}$$

A system of check valves allows crossline relief for dynamic applications with the optional make up facility to compensate for any change in system volume.

## Features

These valves provide complete circuit control and protection in a single valve body, reducing installation time and cost. Smooth, safe performance of dual direction actuators.

## Pilot Ratio

3.5:1 Best suited for applications where the load varies and machine structure can induce instability.

## Description

Motion control and lock valves give static and dynamic control by regulating the flow into and out of hydraulic actuators. When installed close to an actuator, the valve can stop runaway in the event of hose burst. The valves also give dual thermal and overload relief protection.

A low pressure tank or charge line may be connected to the T port to provide a make-up flow to either actuator port.

## Performance Data

### Ratings and Specifications

Figures based on: Oil Temp = 40°C Viscosity = 32 cSt (150 SUS)

Rated flow	150 L/min (40 USgpm)
Max relief pressure	350 bar (5000 psi)
Max load induced pressure	270 bar (4000 psi)
Cartridge material	Working parts hardened and ground steel. External surfaces zinc plated.
Standard housing materials	Steel
Mounting position	Line mounted
Weight	3.7 kg (8.2 lbs)
Seal kit	SK813 (Nitrile) SK813V (Viton®)
Filtration	BS5540/4 Class 18/13 (25 micron nominal)
Temperature range	-30° to +90°C (-22° to +194°F)
Internal leakage	0.3 ml/min (5 dpm)
Nominal viscosity range	5 to 500 cSt

Viton is a registered trademark of E.I. DuPont

## Pressure Drop

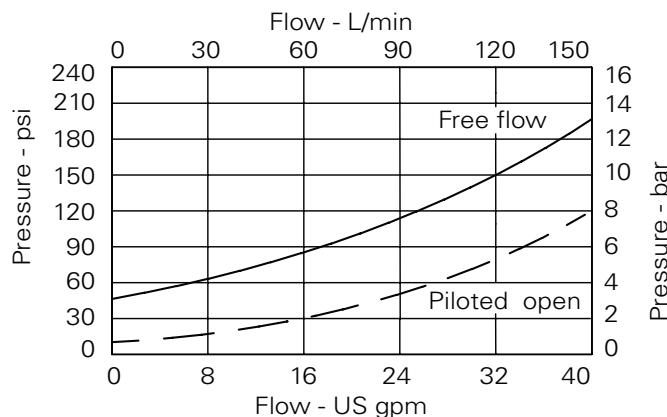

Where measurements are critical request certified drawings. We reserve the right to change specifications without notice.

# ICEEC150 - Motion Control & Lock Valve

Pilot assisted relief

150 L/min (40 USgpm) • 270 bar (4000 psi)

## Model Code

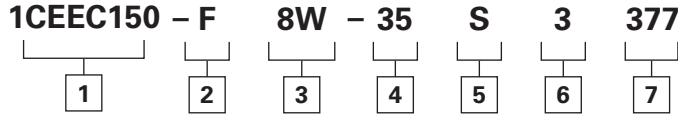

### 1 Basic Code

**1CEEC150** - Cartridges and body

### 2 Adjustment Means

**F** - Screw adjustment  
For fixed versions add setting in 10 bar increments to end of part number. Subject to a ±10% tolerance.

### 3 Port Sizes

Code	Port Size	Housing Number - Body Only
<b>8W</b>	1" BSP Valve & Cyl Port. 1/4" BSP Brake Port	<b>Steel</b> BXP15687-8W-S-377

### 4 Pressure Range @ 4.8 L/min

**Note:** Code based on pressure in bar.  
**35** - 70-35 bar  
Std setting 210 bar  
Std setting made at 4.8 L/min

### 5 Seal Material

**S** - Nitrile (For use with most industrial hydraulic oils.)  
**SV** - Viton (For high temperature and most special fluid applications made at 4.8 L/min)

### 6 Pilot Ratio

**3** - 3.5:1

### 7 Body Material

**377** - Steel

## Dimensions

mm (inch)

### Complete Valve

1" Ports  
Basic Code  
1CEEC150

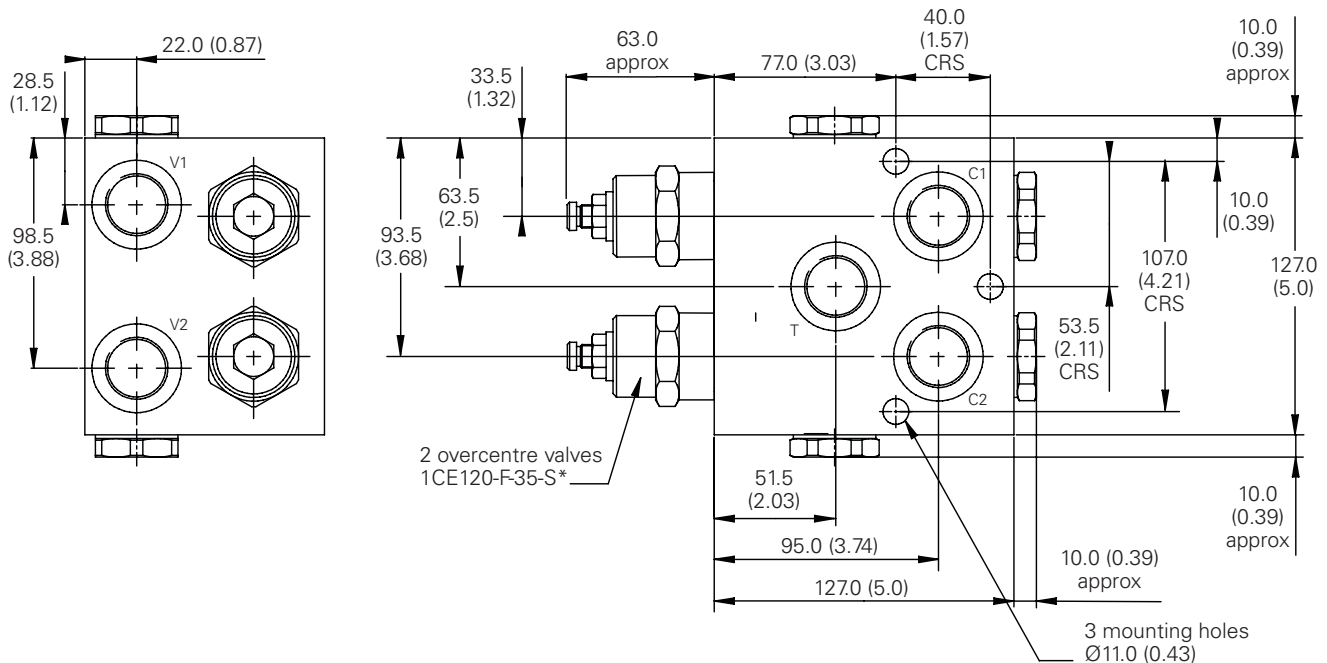

**Note:** Tightening torque of "F" adjuster locknut - 20 to 25 Nm.

Where measurements are critical request certified drawings. We reserve the right to change specifications without notice.

# ICEEC350 - Motion Control & Lock Valve

Pilot assisted relief

300 L/min (80 USgpm) • 270 bar (4000 psi)

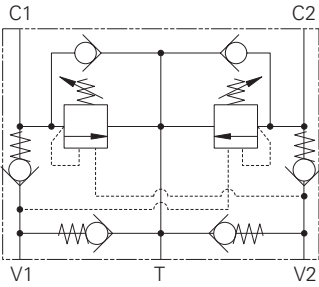

## Operation

The check section allows free flow into the actuator then holds and locks the load against movement. The pilot assisted relief valve section will give controlled movement when pilot pressure is applied. The relief section is normally set to open at a pressure at least 1.3 times the maximum load induced pressure but the pressure required to open the valve and allow movement depends on the pilot ratio of the valve. For optimization of load control and energy

usage, a choice of pilot ratios is available.

The pressure required to open the valve and start actuator movement can be calculated as follows:

$$\text{Pilot Pressure} = \frac{(\text{Relief Setting}) - (\text{Load Pressure})}{\text{Pilot Ratio}}$$

A system of check valves allows crossline relief for dynamic applications with the optional make up facility to compensate for any change in system volume.

## Features

These valves provide complete circuit control and protection in a single valve body, reducing installation time and cost. Smooth, safe performance of dual direction actuators.

## Pilot Ratio

3:1 Best suited for applications where the load varies and machine structure can induce instability.

8:1 Best suited for applications where the load remains relatively constant.

## Description

Motion control and lock valves give static and dynamic control by regulating the flow into and out of hydraulic actuators. When installed close to an actuator, the valve can stop runaway in the event of hose burst. The valves also give dual thermal and overload relief protection.

A low pressure tank or charge line may be connected to the T port to provide a make-up flow to either actuator port.

## Performance Data

### Ratings and Specifications

Figures based on: Oil Temp = 40°C Viscosity = 32 cSt (150 SUS)

Rated flow	300 L/min (80 USgpm)
Max relief pressure	350 bar (5000 psi)
Max load induced pressure	270 bar (4000 psi)
Cartridge material	Working parts hardened and ground steel. External surfaces zinc plated.
Standard housing materials	Steel
Mounting position	Line mounted
Weight	8.2 kg (18.0 lbs)
Seal kit	SK635 (Nitrile) SK635V (Viton®)
Filtration	BS5540/4 Class 18/13 (25 micron nominal)
Temperature range	-30° to +90°C (-22° to +194°F)
Internal leakage	4 ml/min (60 dpm)
Nominal viscosity range	5 to 500 cSt

Viton is a registered trademark of E.I. DuPont

## Pressure Drop

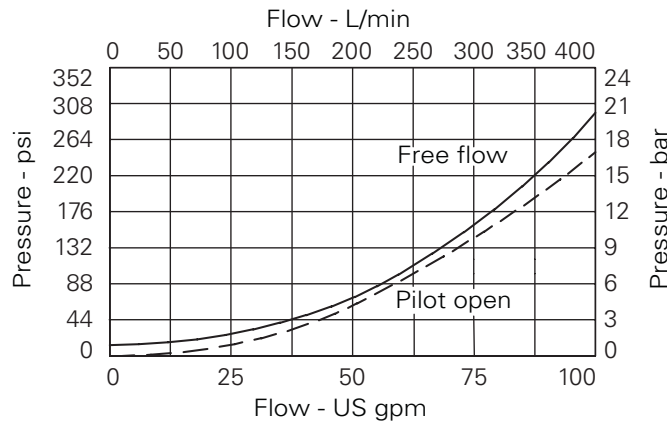

Where measurements are critical request certified drawings. We reserve the right to change specifications without notice.

# ICEEC350 - Motion Control & Lock Valve

Pilot assisted relief

300 L/min (80 USgpm) • 270 bar (4000 psi)

Model Code

**1CEEC350 - F 10W - 35 S 3 377**

1
2
3
4
5
6
7

## 1 Basic Code

**1CEEC350** - Cartridges and body

## 2 Adjustment Means

**F** - Screw adjustment  
For fixed versions add setting in 10 bar increments to end of part number. Subject to a ±10% tolerance.

## 3 Port Sizes - Bodied Valves Only

Code	Port Size	Housing Number
		<b>Steel Single</b>
<b>10W</b>	1 1/4" BSP valve & cyl port. 1/4" BSP brake port	DXP16844-10W-S-377

## 4 Pressure Range @ 4.8 L/min

**Note:** Code based on pressure in bar.  
**35** - 70-35 bar  
Std setting 210 bar  
Std setting made at 4.8 L/min

## 5 Seals

**S** - Nitrile (For use with most industrial hydraulic oils.)  
**SV** - Viton (For high temperature and most special fluid applications made at 4.8 L/min)

## 6 Pilot Ratio

**3** - 3:1  
**8** - 8:1

## 7 Housing Material

**377** - Steel

## Dimensions

mm (inch)

## Complete Valve

1 1/4" Ports  
Basic Code  
1CEEC350

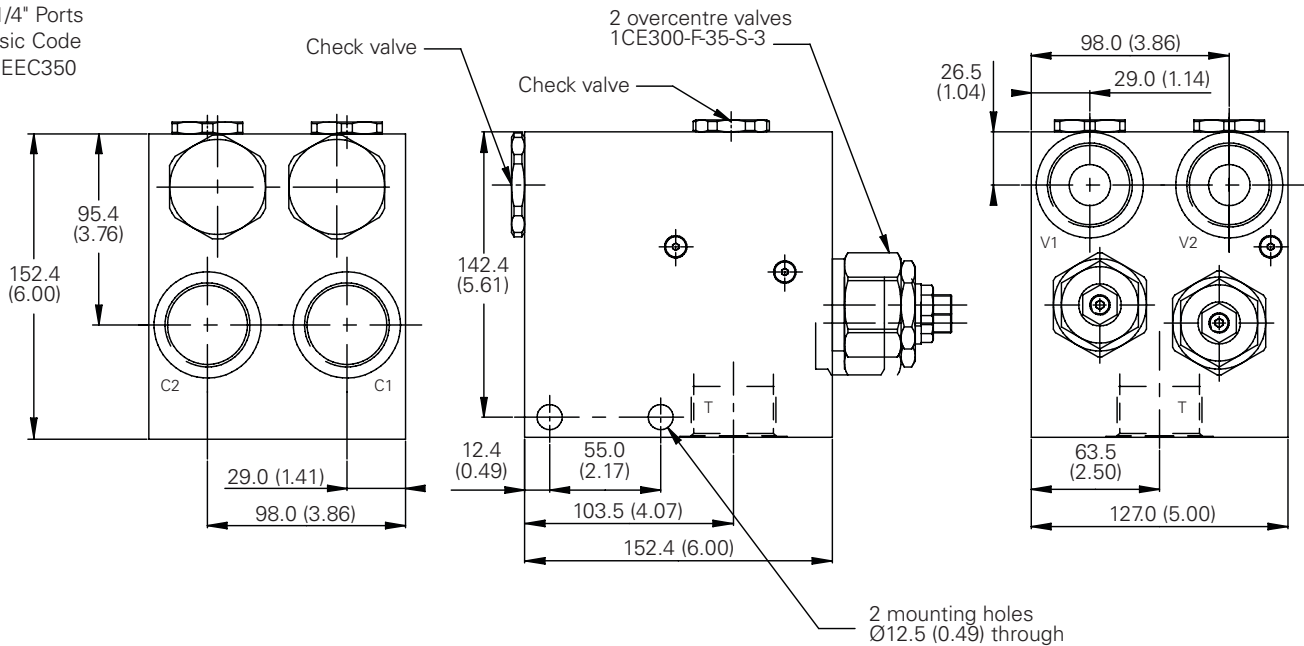

**Note:** Tightening torque of "F" adjuster locknut - 20 to 25 Nm.

Where measurements are critical request certified drawings. We reserve the right to change specifications without notice.

# ICEESH35 - Motion Control & Lock Valve

Pilot assisted relief with brake shuttle  
30 L/min (8 USgpm) • 270 bar (4000 psi)

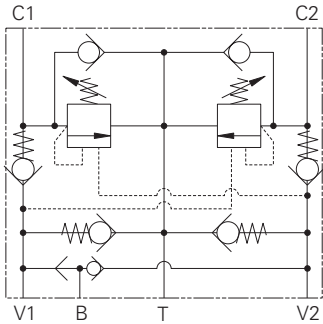

## Operation

The check section allows free flow into the actuator then holds and locks the load against movement. The pilot assisted relief valve section will give controlled movement when pilot pressure is applied. The relief section is normally set to open at a pressure at least 1.3 times the maximum load induced pressure but the pressure required to open the valve and allow movement depends on the pilot ratio of the valve. For optimization of load control and energy

usage, a choice of pilot ratios is available.

The pressure required to open the valve and start actuator movement can be calculated as follows:

$$\text{Pilot Pressure} = \frac{(\text{Relief Setting}) - (\text{Load Pressure})}{\text{Pilot Ratio}}$$

A system of check valves allows crossline relief for dynamic applications with the optional make up facility to compensate for any change in system volume.

## Feature

This valve provides complete circuit control and protection as with the standard motion control valve but has the addition of a brake release shuttle and brake port contained in a single body.

## Pilot Ratio

2.5:1 Best suited for extremely unstable applications such as long booms or flexible frameworks.

5:1 (standard) Best suited for applications where load varies and machine structure can induce instability.

10:1 Best suited for applications where the load remains relatively constant.

F

## Description

Motion control and lock valves give static and dynamic control by regulating the flow into and out of hydraulic actuators. When installed close to an actuator, the valve can stop runaway in the event of hose burst. The valves also give dual thermal and overload relief protection.

A low pressure tank or charge line may be connected to the T port to provide a make-up flow to either actuator port.

The shuttle valve provides a signal from the high pressure side of the actuator to release sprung applied brakes.

## Performance Data

### Ratings and Specifications

Figures based on: Oil Temp = 40°C Viscosity = 32 cSt (150 SUS)

Rated flow	30 L/min (8 USgpm)
Max relief pressure	350 bar (5000 psi)
Max load induced pressure	270 bar (4000 psi)
Cartridge material	Working parts hardened and ground steel. External surfaces electroless nickel plated.
Standard housing materials	Steel
Mounting position	Line mounted
Weight	2.03 kg (4.5 lbs)
Seal kit	SK815 (Nitrile) SK815V (Viton®)
Filtration	BS5540/4 Class 18/13 (25 micron nominal)
Temperature range	-30° to +90°C (-22° to +194°F)
Internal leakage	0.3 ml/min (5 dpm)
Nominal viscosity range	5 to 500 cSt

Viton is a registered trademark of E.I. DuPont

## Pressure Drop

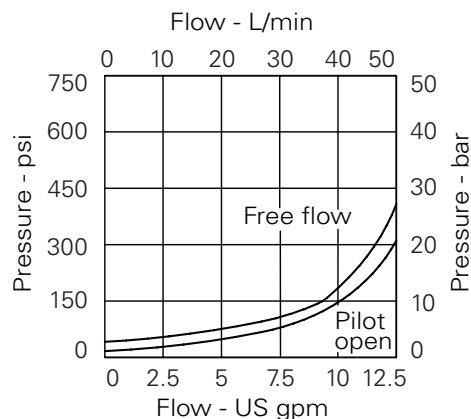

2:5:1 and 5:1 version

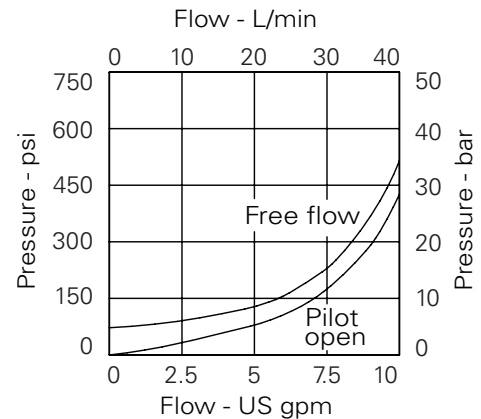

10:1 version

Where measurements are critical request certified drawings. We reserve the right to change specifications without notice.

# 1CEEC SH35 - Motion Control & Lock Valve

Pilot assisted relief with brake shuttle  
 30 L/min (8 USgpm) • 270 bar (4000 psi)

## Model Code

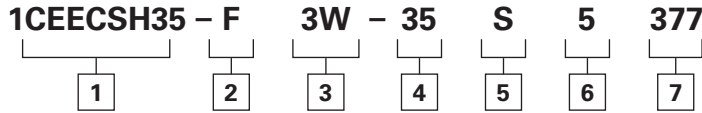

### 1 Function

**1CEEC SH35** - Cartridges and body

### 2 Adjustment Means

**F** - Screw adjustment  
**N** - Fixed - State pressure setting required

For fixed versions add setting in 10 bar increments to end of part number. Subject to a ±10% tolerance.

### 3 Port Sizes - Bodied Valves Only

Code	Port Size	Housing Number - Sub Assembly
<b>Steel</b>		
<b>3W</b>	3/8" BSP Valve & Cyl Port. 1/4" BSP Brake Port	CXP15947-3W-S-377

### 4 Pressure Range @ 4.8 L/min

**Note:** Code based on pressure in bar.

**35** - (2.5:1 and 5:1) 100-350 bar  
 Std setting 210 bar  
 (10:1) 120-350 bar  
 Std setting 210 bar

Std setting made at 4.8 L/min

### 5 Seals

**S** - Nitrile (For use with most industrial hydraulic oils.  
**SV** - Viton (For high temperature and most special fluid applications made at 4.8 L/min

### 6 Pilot Ratios

**2** - 2.5:1  
**5** - 5:1 (Standard)  
**10** - 10:1

### 7 Body Material

**377** - Steel

## Dimensions

mm (inch)

### Complete Valve

3/8" Ports

Basic Code

1CEEC SH35

Internally Cross Piloted

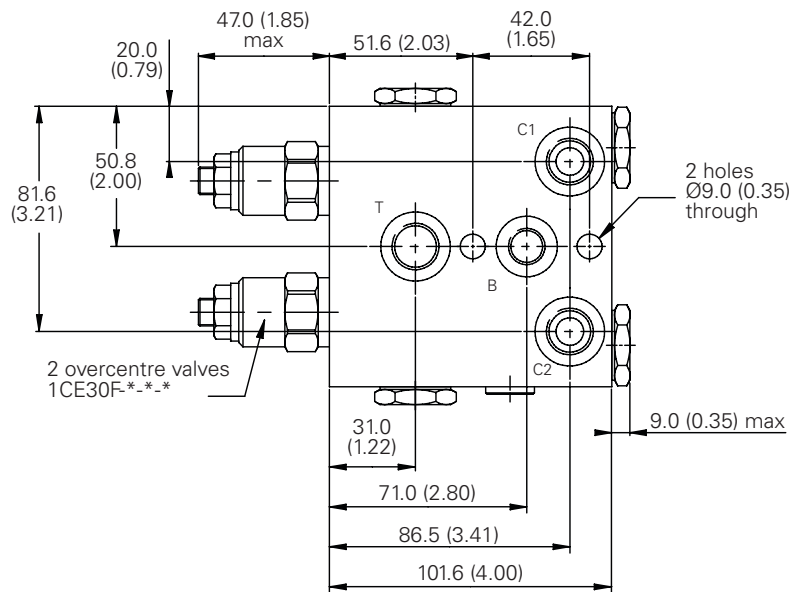
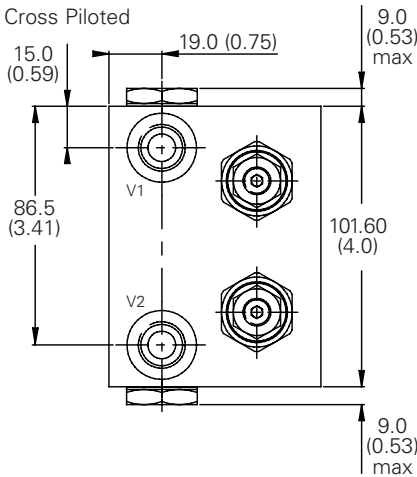

**Note:** Tightening torque of "F" adjuster locknut - 20 to 25 Nm.

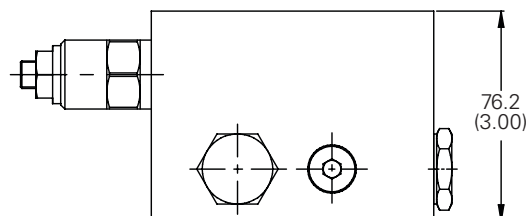

Where measurements are critical request certified drawings. We reserve the right to change specifications without notice.



# ICEESH95 - Motion Control & Lock Valve

Pilot assisted relief with brake shuttle

95 L/min (25 USgpm) • 270 bar (4000 psi)

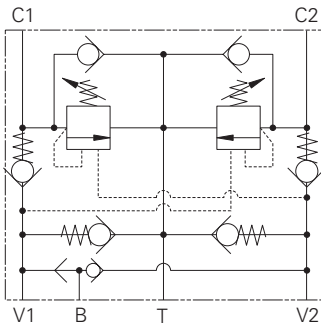

## Operation

The check section allows free flow into the actuator then holds and locks the load against movement. The pilot assisted relief valve section will give controlled movement when pilot pressure is applied. The relief section is normally set to open at a pressure at least 1.3 times the maximum load induced pressure but the pressure required to open the valve and allow movement depends on the pilot ratio of the valve. For optimization of load control and energy

usage, a choice of pilot ratios is available.

The pressure required to open the valve and start actuator movement can be calculated as follows:

$$\text{Pilot Pressure} = \frac{(\text{Relief Setting}) - (\text{Load Pressure})}{\text{Pilot Ratio}}$$

A system of check valves allows crossline relief for dynamic applications with the optional make up facility to compensate for any change in system volume.

## Features

This valve provides complete circuit control and protection as with the standard motion control valve but has the addition of a brake release shuttle and brake port contained in a single body.

## Pilot Ratio

4:1 Best suited for applications where load varies and machine structure can induce instability.

8:1 Best suited for applications where the load remains relatively constant.

## Description

Motion control and lock valves give static and dynamic control by regulating the flow into and out of hydraulic actuators. When installed close to an actuator, the valve can stop runaway in the event of hose burst. The valves also give dual thermal and overload relief protection.

A low pressure tank or charge line may be connected to the T port to provide a make-up flow to either actuator port.

The shuttle valve provides a signal from the high pressure side of the actuator to release sprung applied brakes.

## Performance Data

### Ratings and Specifications

Figures based on: Oil Temp = 40°C Viscosity = 32 cSt (150 SUS)

Rated flow	95 L/min (25 USgpm)
Max relief pressure	350 bar (5000 psi) <b>(35)</b> , 225 bar (3260 psi) <b>(20)</b>
Max load induced pressure	270 bar (4000 psi) <b>(35)</b> , 160 bar (2300 psi) <b>(20)</b>
Cartridge material	Working parts hardened and ground steel. External surfaces electroless nickel plated.
Standard housing materials	Steel
Mounting position	Line mounted
Weight	3.70 kg (8.20 lbs)
Seal kit	SK814 (Nitrile) SK814V (Viton®)
Filtration	BS5540/4 Class 18/13 (25 micron nominal)
Temperature range	-30° to 90°C (-22° to +194°F)
Internal leakage	0.3 ml/min (5 dpm)
Nominal viscosity range	5 to 500 cSt

Viton is a registered trademark of E.I. DuPont

## Pressure Drop

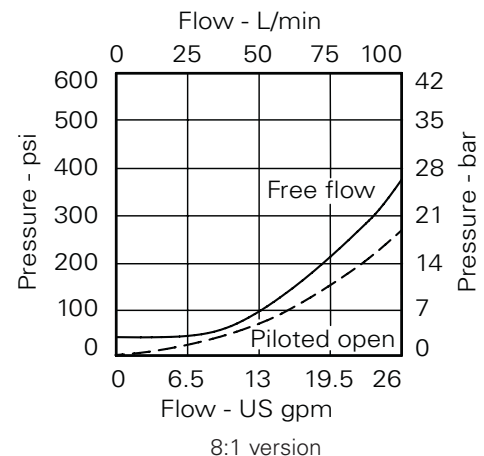
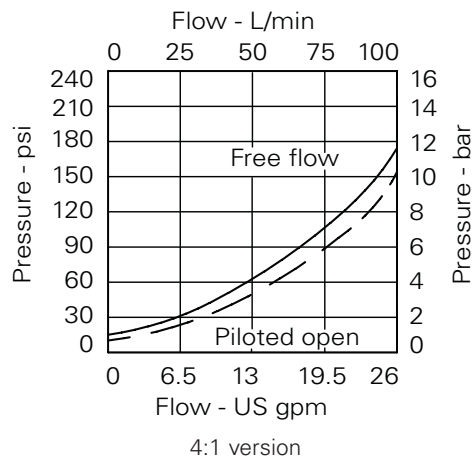

Where measurements are critical request certified drawings. We reserve the right to change specifications without notice.

# ICEESH95 - Motion Control & Lock Valve

Pilot assisted relief with brake shuttle

95 L/min (25 USgpm) • 270 bar (4000 psi)

## Model Code

**1** **CEECSH95 - F**    **3** **6W - 35**    **5** **S**    **6** **4**    **7** **377**

### 1 Basic Code

**1CEECSH95** - Cartridges and body

### 2 Adjustment Means

**F** - Screw adjustment  
**N** - Fixed - state pressure setting required.

For fixed versions add setting in 10 bar increments to end of part number. Subject to a ±10% tolerance.

### 3 Port Size

Code	Port Size	Housing Number - Body Only
<b>6W</b>	3/4" BSP Valve & Cyl Port. 1/4" BSP Brake Port	<b>Steel</b> BXP15936-6W-S-377

### 4 Pressure Range @ 4.8 L/min

**Note:** Code based on pressure in bar.

**20** - 70-225 bar  
 Std setting 100 bar.  
**35** - 200-350 bar  
 Std setting 210 bar.

Std setting made at 4.8 L/min

### 5 Seals

**S** - Nitrile (For use with most industrial hydraulic oils.  
**SV** - Viton (For high temperature and most special fluid applications made at 4.8 L/min

### 6 Pilot Ratio

**4** - 4:1 (Standard)  
**8** - 8:1

### 7 Body Material

**377** - Steel

## Dimensions

mm (inch)

### Complete Valve

3/4" Ports

Basic Code

1CEECSH95

Internally Cross Piloted

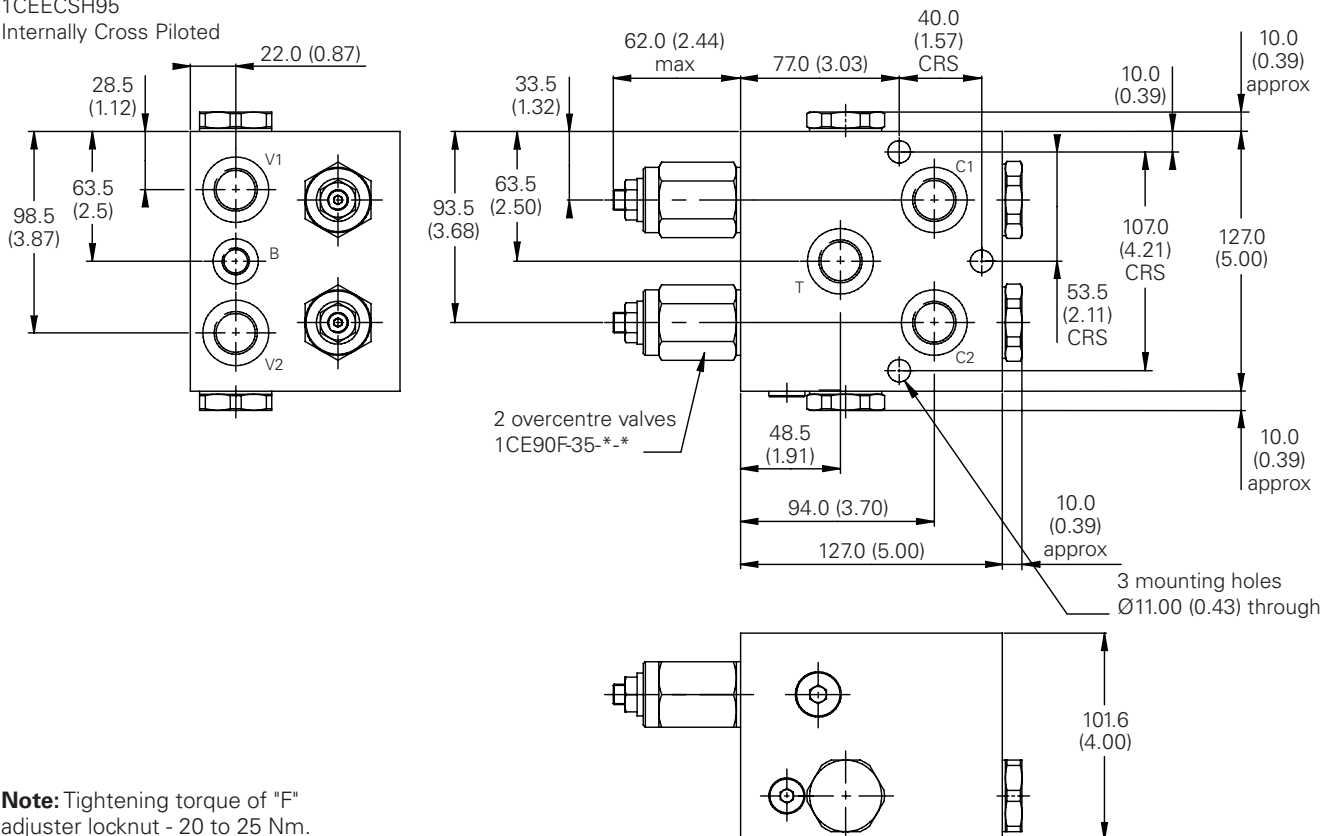

**Note:** Tightening torque of "F" adjuster locknut - 20 to 25 Nm.

Where measurements are critical request certified drawings. We reserve the right to change specifications without notice.

# ICEESH150 - Motion Control & Lock Valve

Pilot assisted relief with brake shuttle

150 L/min (40 USgpm) • 270 bar (4000 psi)

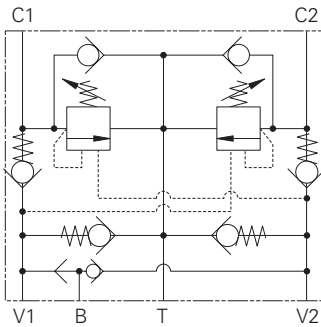

## Operation

The check section allows free flow into the actuator then holds and locks the load against movement. The pilot assisted relief valve section will give controlled movement when pilot pressure is applied. The relief section is normally set to open at a pressure at least 1.3 times the maximum load induced pressure but the pressure required to open the valve and allow movement depends on the pilot ratio of the valve. For optimization of load control and energy

usage, a choice of pilot ratios is available.

The pressure required to open the valve and start actuator movement can be calculated as follows:

$$\text{Pilot Pressure} = \frac{(\text{Relief Setting}) - (\text{Load Pressure})}{\text{Pilot Ratio}}$$

A system of check valves allows crossline relief for dynamic applications with the optional make up facility to compensate for any change in system volume.

## Features

This valve provides complete circuit control and protection as with the standard motion control valve but has the addition of a brake release shuttle and brake port contained in a single body.

## Pilot Ratio

3.5:1 Best suited for applications where load varies and machine structure can induce instability.

## Description

Motion control and lock valves give static and dynamic control by regulating the flow into and out of hydraulic actuators. When installed close to an actuator, the valve can stop runaway in the event of hose burst. The valves also give dual thermal and overload relief protection.

A low pressure tank or charge line may be connected to the T port to provide a make-up flow to either actuator port.

The shuttle valve provides a signal from the high pressure side of the actuator to release sprung applied brakes.

## Performance Data

### Ratings and Specifications

*Performance data is typical with fluid at 32 cST (150 SUS)*

Rated flow	150 L/min (40 USgpm)
Max relief pressure	350 bar (5000 psi)
Max load induced pressure	270 bar (4000 psi)
Cartridge material	Working parts hardened and ground steel External surfaces electroless nickel plated
Standard housing materials	Steel
Mounting position	Line mounted
Weight	3.7 kg (8.2 lbs)
Seal kit	SK813 (Nitrile) SK813V (Viton®)
Filtration	BS5540/4 Class 18/13 (25 micron nominal)
Temperature range	-30° to +90°C (-22° to +194°F)
Internal leakage	0.3 ml/min (5 dpm)
Nominal viscosity range	5 to 500 cSt

Viton is a registered trademark of E.I. DuPont

## Pressure Drop

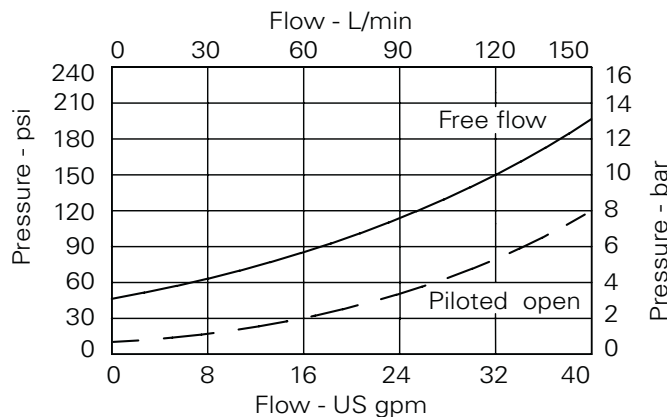

Where measurements are critical request certified drawings. We reserve the right to change specifications without notice.

# 1CEEC SH150 - Motion Control & Lock Valve

Pilot assisted relief with brake shuttle

150 L/min (40 USgpm) • 270 bar (4000 psi)

Model Code

**1CEEC SH150 – F 8W – 35 S 3 377**

1    2    3    4    5    6    7

## 1 Basic Code

**1CEEC SH150** - Cartridges and body

## 2 Adjustment Means

F - Screw adjustment

## 3 Port Size

Code	Port Size	Housing Number - Body Only
<b>Steel</b>		
<b>8W</b>	1" BSP valve & cyl port. 1/4" BSP brake port	BXP15930-8W-S-377

## 4 Pressure Range @ 4.8 L/min

**Note:** Code based on pressure in bar.

**35** - 70-35 bar  
Std setting 210 bar

Std setting made at 4.8 L/min

## 5 Seals

**S** - Nitrile (For use with most industrial hydraulic oils.

**SV** - Viton (For high temperature and most special fluid applications made at 4.8 L/min

## 6 Pilot Ratio

**3** - 3.5:1

## 7 Body Material

**377** - Steel

## Dimensions

mm (inch)

## Complete Valve

1 Port

Basic Code

1CEEC SH150

Internally Cross Piloted

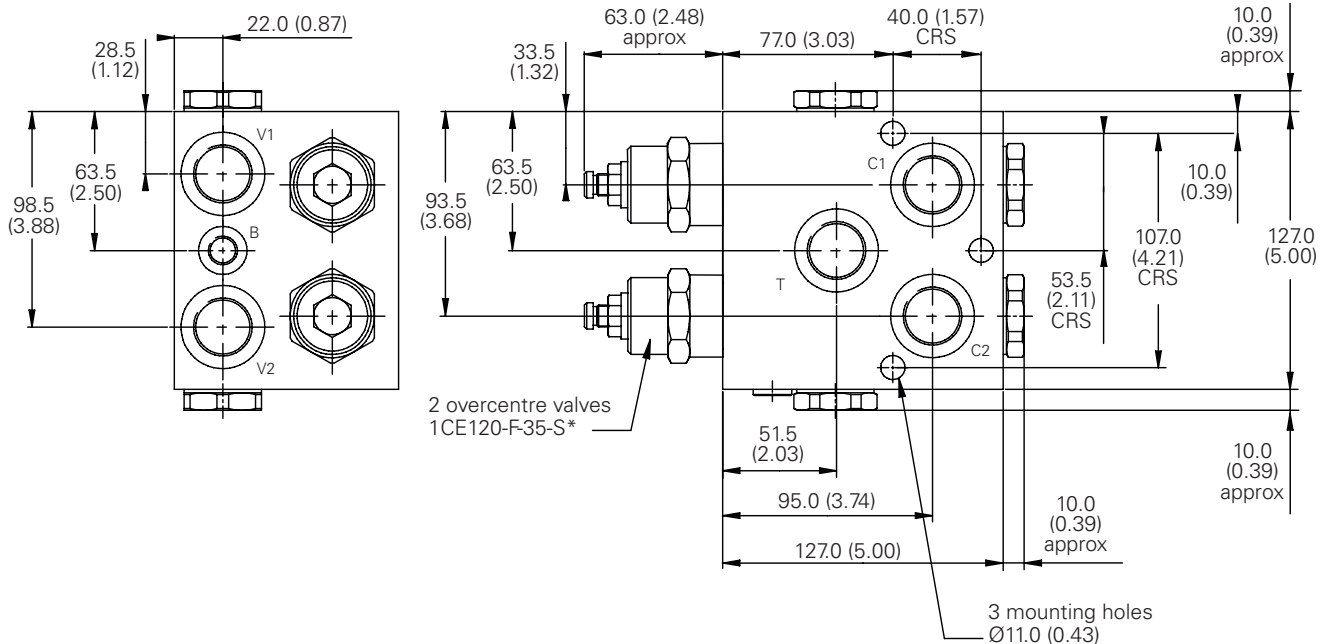

**Note:** Tightening torque of "F" adjuster locknut - 20 to 25 Nm.

Where measurements are critical request certified drawings. We reserve the right to change specifications without notice.

# ICEESH350 - Motion Control & Lock Valve

Pilot assisted relief with brake shuttle

350 L/min (80 USgpm) • 270 bar (4000 psi)

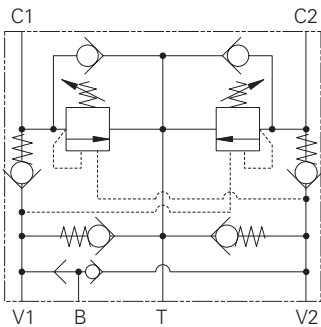

## Operation

The check section allows free flow into the actuator then holds and locks the load against movement. The pilot assisted relief valve section will give controlled movement when pilot pressure is applied. The relief section is normally set to open at a pressure at least 1.3 times the maximum load induced pressure but the pressure required to open the valve and allow movement depends on the pilot ratio of the valve. For optimization of load control and energy

usage, a choice of pilot ratios is available.

The pressure required to open the valve and start actuator movement can be calculated as follows:

$$\text{Pilot Pressure} = \frac{(\text{Relief Setting}) - (\text{Load Pressure})}{\text{Pilot Ratio}}$$

A system of check valves allows crossline relief for dynamic applications with the optional make up facility to compensate for any change in system volume.

## Features

This valve provides complete circuit control and protection as with the standard motion control valve but has the addition of a brake release shuttle and brake port contained in a single body.

## Pilot Ratio

3:1 (standard) Best suited for applications where load varies and machine structure can induce instability.

8:1 Best suited for applications where the load remains relatively constant.

## Performance Data

### Ratings and Specifications

Figures based on: Oil Temp = 40°C Viscosity = 32 cSt (150 SUS)

Rated flow	350 L/min (80 USgpm)
Max relief pressure	350 bar (5000 psi)
Max load induced pressure	270 bar (4000 psi)
Cartridge material	Working parts hardened and ground steel. External surfaces electroless nickel plated.
Standard housing materials	Steel
Mounting position	Line mounted
Weight	8.2 kg (18.0 lbs)
Seal kit	SK635 (Nitrile) SK635V (Viton®)
Filtration	BS5540/4 Class 18/13 (25 micron nominal)
Temperature range	-30° to +90°C (-22° to +194°F)
Internal leakage	4 ml/min (60 dpm)
Nominal viscosity range	5 to 500 cSt

Viton is a registered trademark of E.I. DuPont

## Description

Motion control and lock valves give static and dynamic control by regulating the flow into and out of hydraulic actuators. When installed close to an actuator, the valve can stop runaway in the event of hose burst. The valves also give dual thermal and overload relief protection.

A low pressure tank or charge line may be connected to the T port to provide a make-up flow to either actuator port.

The shuttle valve provides a signal from the high pressure side of the actuator to release sprung applied brakes.

## Pressure Drop

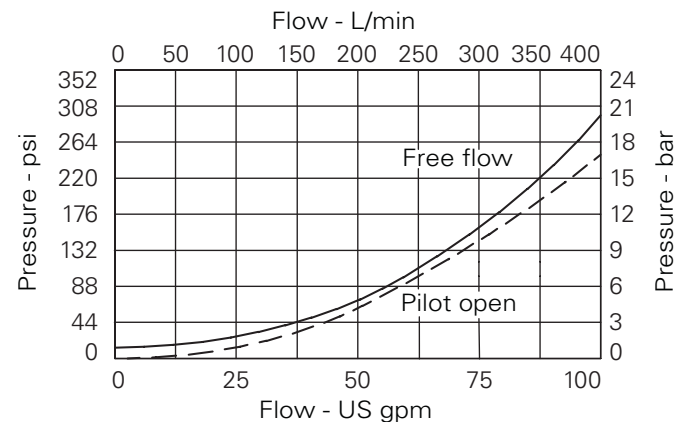

Where measurements are critical request certified drawings. We reserve the right to change specifications without notice.

# 1CEESH350 - Motion Control & Lock Valve

Pilot assisted relief with brake shuttle

350 L/min (80 USgpm) • 270 bar (4000 psi)

Model Code

**1CEESH350 – F 10W – 35 S 3 377**

1
2
3
4
5
6
7

## 1 Basic Code

**1CEESH350** - Cartridges and body

## 2 Adjustment Means

**F** - Screw adjustment

## 3 Port Size

Code	Port Size	Housing Number - Body Only
		<b>Steel</b>
<b>10W</b>	1 1/4" BSP valve & cyl port. 1/4" BSP brake port	DXP22047-10W-S-377

## 4 Pressure Range

**Note:** Code based on pressure in bar.

**35** - 70-350 bar

Std setting 210 bar

Std setting made at 4.8 L/min

## 5 Seals

**S** - Nitrile (For use with most industrial hydraulic oils.

**SV** - Viton (For high temperature and most special fluid applications made at 4.8 L/min

## 6 Pilot Ratio

**3** - 3:1 Standard

**8** - 8:1

## 7 Body Material

**377** - Steel

## Dimensions

mm (inch)

## Complete Valve

1 1/4" Ports

Basic Code

1CEESH350

Internally Cross Piloted

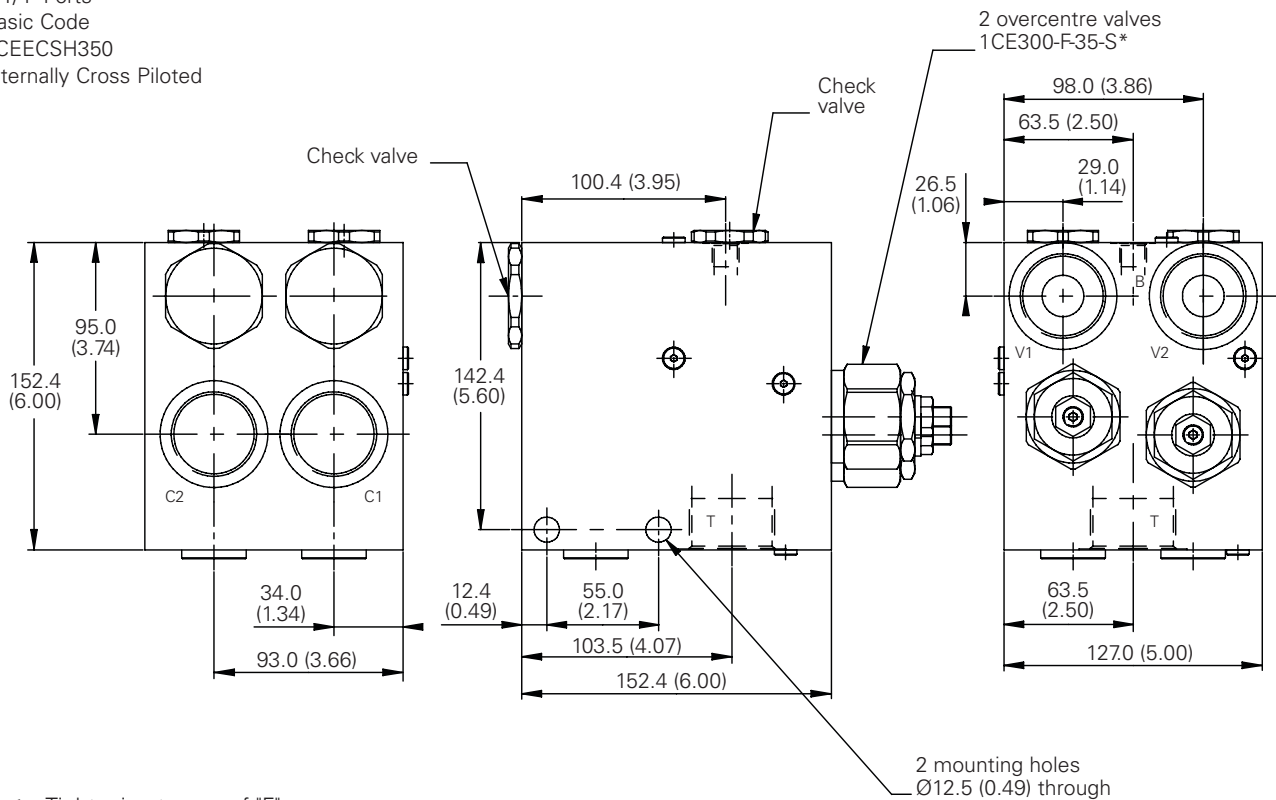

**Note:** Tightening torque of "F" adjuster locknut - 20 to 25 Nm

Where measurements are critical request certified drawings. We reserve the right to change specifications without notice.



# Beyond standard value

## Industrial hose styles include:

- Armorcat®
- Boston® Bulldog Gold
- Concord® Steam
- Easy Couple
- Royalflex®
- Bobcat®
- Chemcat®
- Contractors Water
- Puma®
- Ultraforce®

## New Bio-Diesel hose style:

- GH100 ESP™ 

## New CARB/EPA/IMCI approved fuel products:

- EH049 ESP™ Tubing 
- EH089 ESP™ Hose 

## Industrial Hose Solutions

Eaton has the breadth and depth of products readily available to meet specific chemical and industrial hose needs—all at a reasonable price. Eaton and our vast distribution network are focused on providing sustainable products and solutions designed to conserve resources and protect the environment. From low-pressure air and water to hazardous chemical transfer, look to Eaton's Industrial Hose Solutions.

Check the Distributor Locator link at the following site for the local Eaton industrial hose distributor closest to you to get an update on "Industrial Hose Solutions"

<http://www.eaton.com/hydraulics/industrialhose>

# EATON

Powering Business Worldwide



An Eaton Green Solution

# ICEBL - BoomLoc Valves

Hose Burst Protection (REF: ISO8643)

The valves function is to prevent uncontrolled lowering of the boom in the event of hose rupture.

These valves comply with International Standard ISO8643 for hydraulic excavators and backhoe loaders incorporating servo pilot systems. The valves' function is to prevent uncontrolled lowering of the boom in the event of hose rupture. Closure of the valve is activated by bringing the main control valve lever to the neutral position.

By separating the relief and pilot function into two individual cartridges, the pilot cartridge has no relieving function, hence any load on the valve does not affect its opening characteristics.

Consequently, the valve will always open at the same pilot pressure/joystick position, regardless of load. This feature enables the valve to be tuned to open in harmony with the machine's own main control valve, giving better control.

The pilot cartridge is generally set to dwell 1 to 2 bar behind the main control valve, therefore the Integrated Hydraulics valve takes control in the event of hose failure.

When fitted to the arm/dipper cylinder, this dwell behind the main control valve prevents acceleration when 'arm down' is selected.

Fig. 1 and 2 show typical circuits utilizing these components.

Line mountings or SAE flange mountings are available for direct fitment to the actuator. Where line mounted models are used it is essential that steel pipes are used between the valve and the actuator.

All components are manufactured in steel and are electroplated for corrosion protection.

## Typical Circuit

### Compact Machinery

(see page F-640 to F-650)  
For flows up to 30 and 40 L/min

Fig. 1

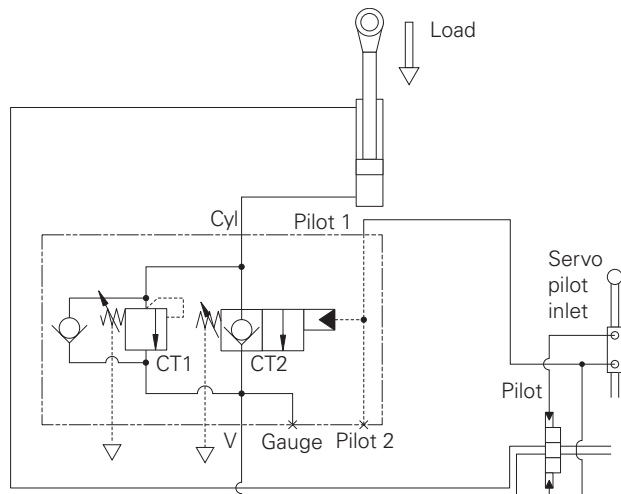

### Heavy Machinery

(see page F-600 to F-630)  
For flows up to 250, 350 and 550 L/min

Fig. 2

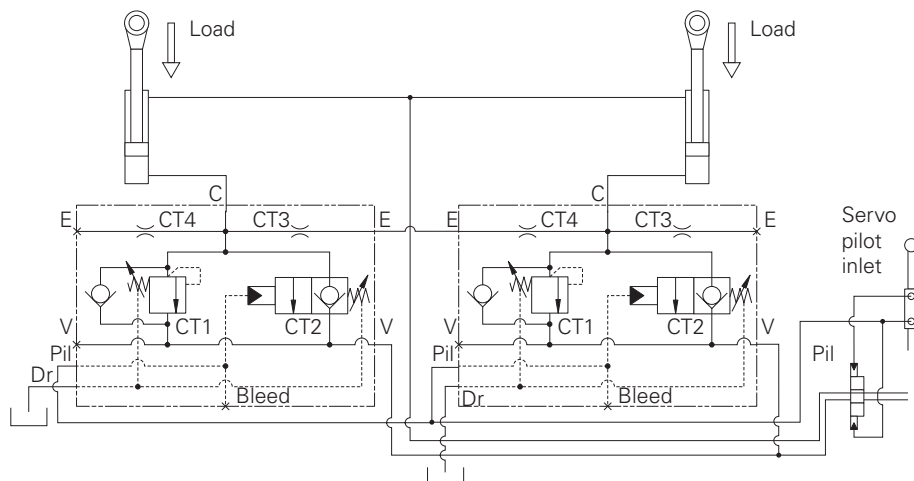

Where measurements are critical request certified drawings. We reserve the right to change specifications without notice.

# ICEBL256 - BoomLoc Valve

Hose burst protection, flange mounted with independent pilot control (Ref. ISO 8643)

250 L/min (66 USgpm) • 350 bar (5000 psi)

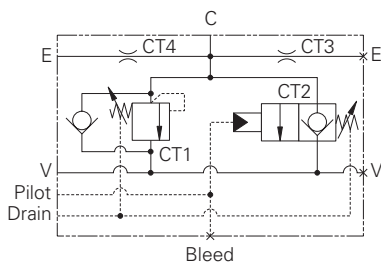

## Operation

By connecting the hose rupture valve pilot in parallel with the directional spool valve pilot, and adjusting the opening characteristics of the hose rupture valve to suit that of the spool valve "BoomLoc" may be set so as not to interfere with the normal operation of the machine.

Fine adjustment of the pilot pressure permits the optimum setting to be made in differing operating systems.

Both the pilot and the relief sections are unaffected by back pressure, enabling the service line relief's to operate normally. In the event of hose failure, the control will be passed from the main spool to the "BoomLoc" valve, maintaining control of the cylinder.

Regardless of the load the pilot pressure requirement remains constant as the valve is unaffected by load induced pressure, the poppet being fully balanced with zero differential area.

## Features

This is a compact design with good dirt tolerance. Hardened poppets and seats provide excellent load holding characteristics with all the advantages of the cartridge insert.

## Typical Circuit

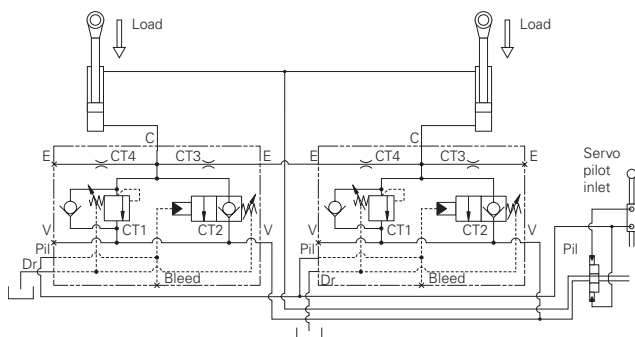

## Description

These overcenter valves are suitable for use on the boom and dipper cylinders of an excavator to help the manufacturer or user comply with standard ISO8643.

They were designed to give relief, load holding and hose failure protection to systems where a pilot system controls the directional valves.

## Performance Data

### Ratings and Specifications

Figures based on: Oil Temp = 40°C Viscosity = 32 cSt (150 SUS)

Rated flow	250 L/min (66 USgpm)
Max setting	350 bar (5000 psi)
Cartridge material	Working parts hardened and ground steel. External surfaces electroless nickel plated and passivated.
Standard housing materials	Bright drawn mild steel bar. Zinc plated and passivated.
Mounting position	Flange mounted
Weight	7.5 kg (16.5 lbs)
Seal kit	SK1162P (Polyurethane/Nitrile)
Filtration	BS5540/4 Class 18/13 (25 micron nominal)
Temperature range	-30° to +90°C (-22° to +194°F)
Internal leakage	0.6 ml/min (10 dpm)
Nominal viscosity range	5 to 500 cSt

# ICEBL256 - BoomLoc Valve

Hose burst protection, flange mounted with independent pilot control (Ref. ISO 8643)  
 250 L/min (66 USgpm) • 350 bar (5000 psi)

## Model Code

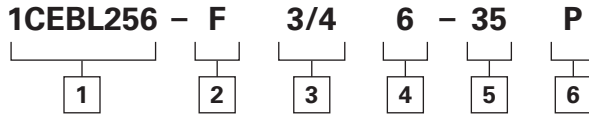

### 1 Basic Code

**1CEBL256** - Cartridges and body

### 2 Adjustment Means

**F** - Screw adjustment

For fixed versions add setting in 10 bar increments to end of part number. Subject to a ±10% tolerance.

### 3 Port Size

**3/4** - 3/4" SAE flange cylinder port slotted for 3000 & 6000  
 3/4" SAE Flange valve port (thread G1/2)  
 1/8" BSP bleed port  
 1/4" BSP all other ports

### 4 SAE Port Type

**6** - SAE 6000 (Valve port)

### 5 Pressure Range @ 4.8 L/min

**Note:** Code based on pressure in bar.

**35** - 70-350 bar.

Std setting 350 bar

Std setting made at 4.8 L/min

### 6 Seals

**P** - Contains polyurethane and standard seal.

## Dimensions

mm (inch)

## Flange Mounted

Basic Code

**1CEBL256**

**Note:** Cylinder port bolt holes are slotted for fitment to both SAE 3000 & SAE 6000 mounting faces.

**Note:** Tightening torque of "F" adjuster locknut - 20 to 25 Nm.

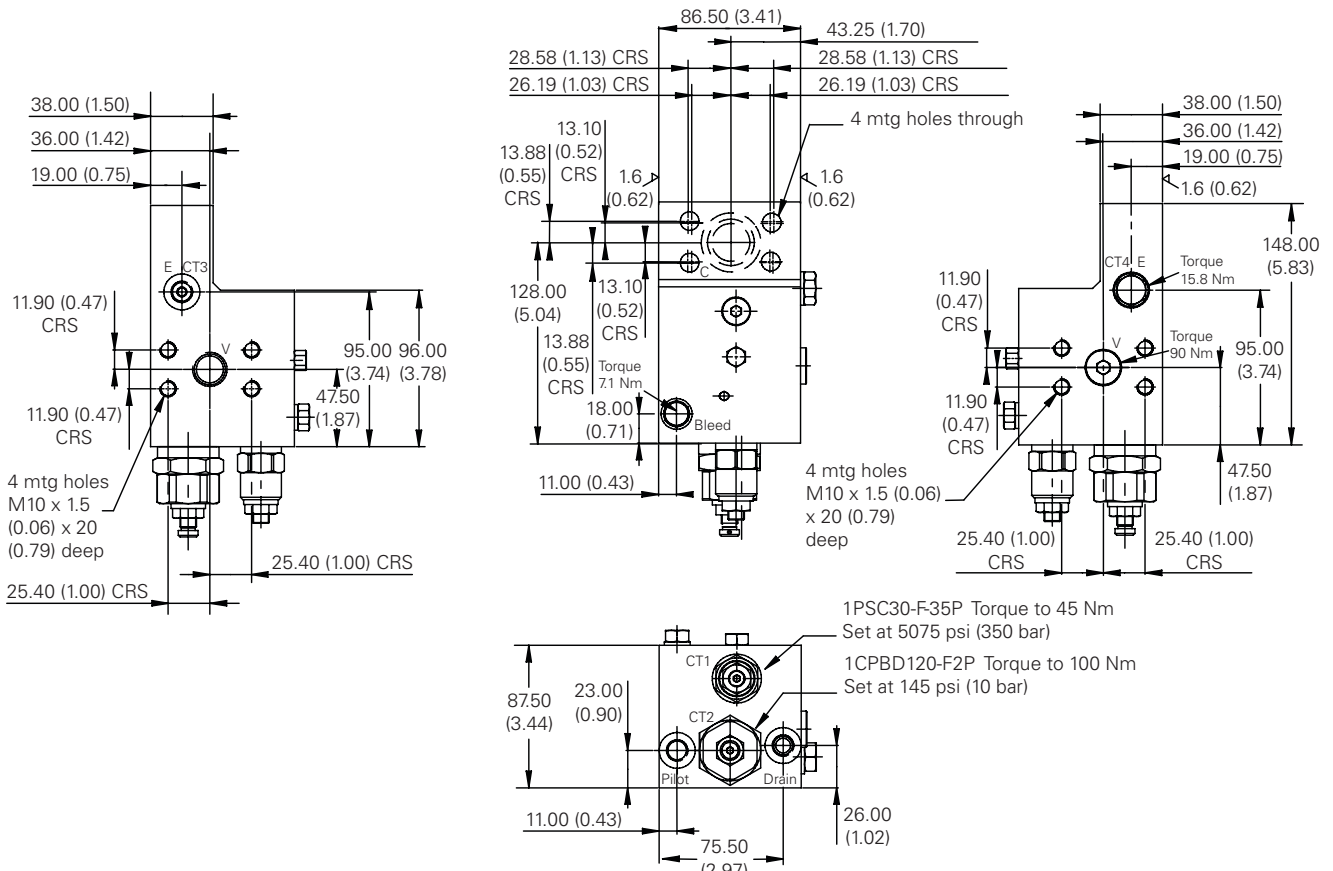

Where measurements are critical request certified drawings. We reserve the right to change specifications without notice.



# ICEBL356 - BoomLoc Valve

Hose burst protection, flange mounted with independent pilot control (Ref. ISO 8643)  
 350 L/min (92 USgpm) • 350 bar (5000 psi)

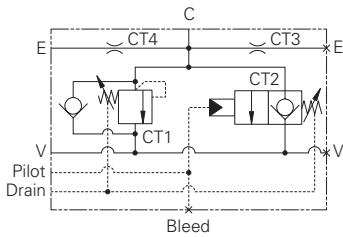

**Typical Circuit**

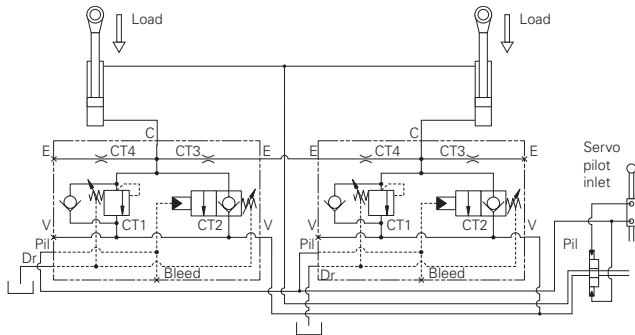

## Operation

By connecting the hose rupture valve pilot in parallel with the directional spool valve pilot, and adjusting the opening characteristics of the hose rupture valve to suit that of the spool valve "BoomLoc" may be set so as not to interfere with the normal operation of the machine.

Fine adjustment of the pilot pressure permits the optimum setting to be made in differing operating systems.

Both the pilot and the relief sections are unaffected by backpressure, enabling the service line reliefs to operate normally. In the event of hose failure, the control will be passed from the main spool to the "BoomLoc" valve, maintaining control of the cylinder.

Regardless of the load the pilot pressure requirement remains constant as the valve is unaffected by load induced pressure, the poppet being fully balanced with zero differential area.

## Features

This is a compact design with good dirt tolerance. Hardened poppets and seats provide excellent load holding characteristics with all the advantages of the cartridge insert.

F

## Description

These overcenter valves are suitable for use on the boom and dipper cylinders of an excavator to help the manufacturer or user comply with standard ISO8643.

They were designed to give relief, load holding and hose failure protection to systems where a pilot system controls the directional valves.

## Performance Data

### Ratings and Specifications

*Figures based on: Oil Temp = 40°C Viscosity = 32 cSt (150 SUS)*

Rated flow	350 L/min (92 USgpm)
Max setting	350 bar (5000 psi)
Cartridge material	Working parts hardened and ground steel. External surfaces electroless nickel plated and passivated.
Standard housing materials	Bright drawn M.S. bar zinc plated and passivated
Mounting position	Flange mounted
Weight	7.5 kg (16.5 lbs)
Seal kit	SK1161P (Polyurethane/Nitrile)
Filtration	BS5540/4 Class 18/13 (25 micron nominal)
Temperature range	-30° to 90°C (-22° to +194°F)
Internal leakage	0.6 ml/min (10 dpm)
Nominal viscosity range	5 to 500 cSt

Where measurements are critical request certified drawings. We reserve the right to change specifications without notice.

# ICEBL356 - BoomLoc Valve

Hose burst protection, flange mounted with independent pilot control (Ref. ISO 8643)  
 350 L/min (92 USgpm) • 350 bar (5000 psi)

## Model Code

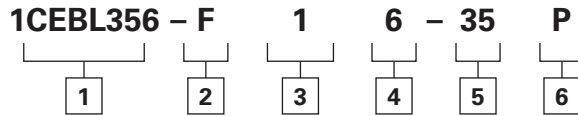

### 1 Basic Code

**1CEBL356** - Cartridges and body

### 2 Adjustment Means

**F** - Screw adjustment  
 For fixed versions add setting in 10 bar increments to end of part number. Subject to a ±10% tolerance.

### 3 Port Size

**1** - 1" SAE Flange cylinder port (slotted for 3000 & 6000)  
 1" SAE Flange valve port (thread G3/4)  
 1/8" BSP bleed port  
 1/4" BSP all other ports

### 4 SAE Port Type

**6** - SAE 6000 (valve port)

### 5 Pressure Range @ 4.8 L/min

**Note:** Code based on pressure in bar.  
**35** - 70-350 bar.  
 Std setting 350 bar  
 Std setting made at 4.8 L/min

### 6 Seals

**P** - Contains polyurethane and standard seal.

## Dimensions

mm (inch)

### Complete Valve

Flange Mounted  
 Basic Code  
 1CEBL356

**Note:** Cylinder port bolt holes are slotted for fitment to both SAE 3000 & SAE 6000 mounting faces.

**Note:** Tightening torque of "F" adjuster locknut - 20 to 25 Nm.

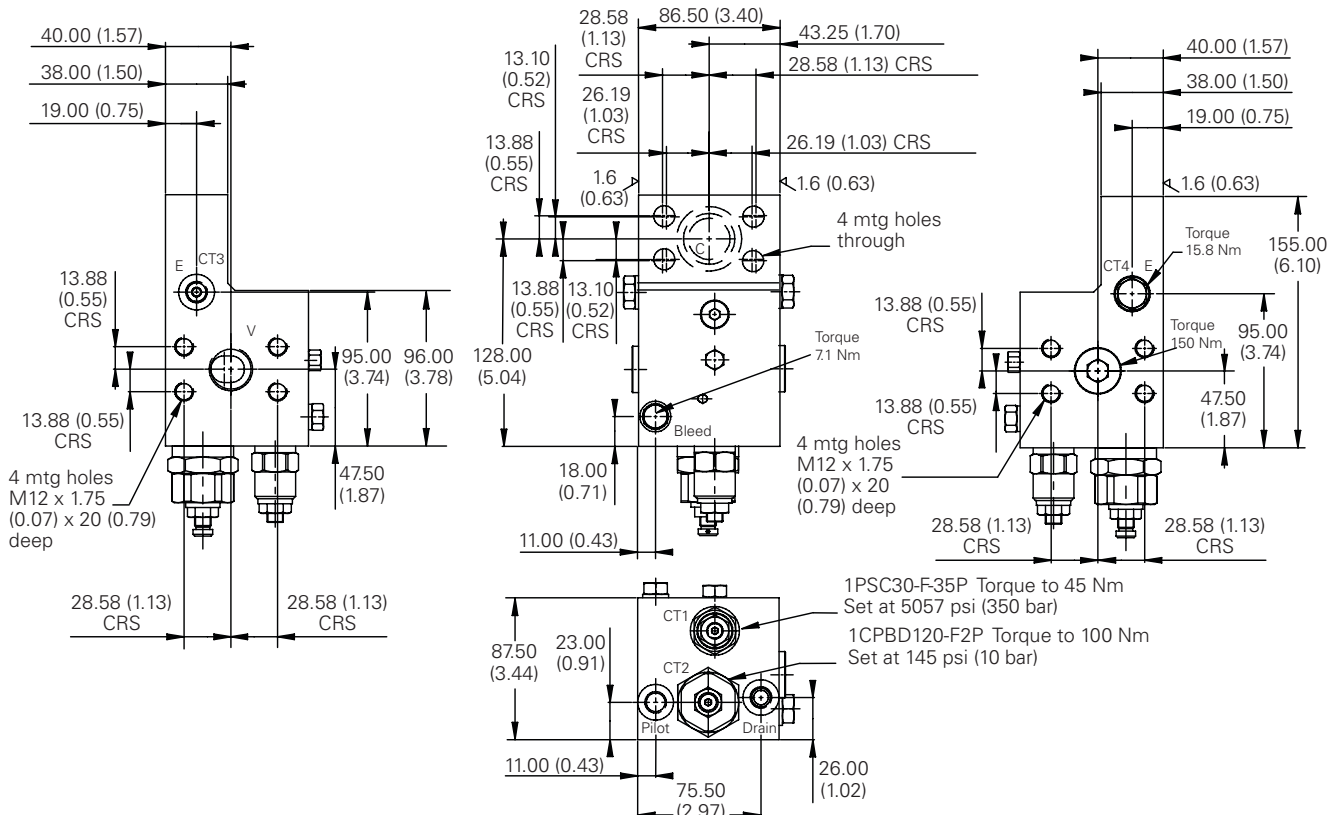

Where measurements are critical request certified drawings. We reserve the right to change specifications without notice.

# ICEBL556 - BoomLoc Valve

Hose burst protection, flange mounted with independent pilot control (Ref. ISO 8643)

550 L/min (145 USgpm) • 400 bar (5800 psi)

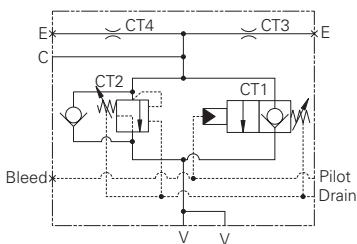

## Operation

By connecting the hose rupture valve pilot in parallel with the directional spool valve pilot, and adjusting the opening characteristics of the hose rupture valve to suit that of the spool valve "BoomLoc" may be set so as not to interfere with the normal operation of the machine. Fine adjustment of the pilot

pressure permits the optimum setting to be made in differing operating systems.

Both the pilot and the relief sections are unaffected by backpressure, enabling the service line reliefs to operate normally. In the event of hose failure, the control will be passed from the main spool to the "BoomLoc" valve, maintaining control of the cylinder.

## Features

This is a compact design with good dirt tolerance. Hardened poppets and seats provide excellent load holding characteristics with all the advantages of the cartridge insert.

Regardless of the load the pilot pressure requirement remains constant as the valve is unaffected by load induced pressure, the poppet being fully balanced with zero differential area.

## Typical Circuit

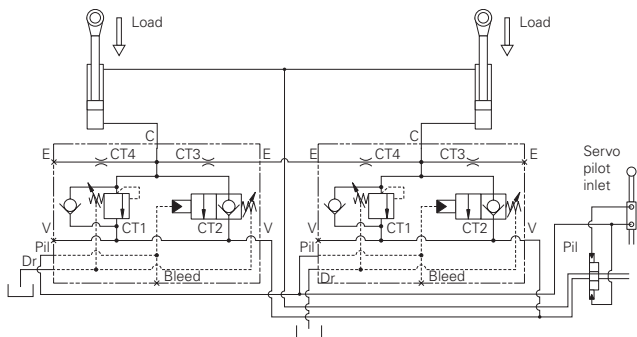

F

## Description

These overcenter valves are suitable for use on the boom and dipper cylinders of an excavator to help the manufacturer or user comply with standard ISO8643.

They were designed to give relief, load holding and hose failure protection to systems where a pilot system controls the directional valves.

## Performance Data

### Ratings and Specifications

Figures based on: Oil Temp = 40°C Viscosity = 32 cSt (150 SUS)

Rated flow	550 L/min (145 USgpm)
Max setting	400 bar (5800 psi)
Cartridge material	Working parts hardened and ground steel. External surfaces electroless nickel plated and passivated.
Standard housing materials	Bright drawn M.S. bar zinc plated and passivated
Mounting position	Flange mounted
Weight	21 kg (46.2 lbs)
Seal kit	SK1163P (Polyurethane/Nitrile)
Filtration	BS5540/4 Class 18/13 (25 micron nominal)
Temperature range	-30° to +90°C (-22° to +194°F)
Internal leakage	4.3 ml/min (70 dpm)
Nominal viscosity range	5 to 500 cSt

Where measurements are critical request certified drawings. We reserve the right to change specifications without notice.

# ICEBL556 - BoomLoc Valve

Hose burst protection, flange mounted with independent pilot control (Ref. ISO 8643)  
 550 L/min (145 USgpm) • 400 bar (5800 psi)

## Model Code

**1CEBL556 - F 5/4 6 - 40 P**

1   
 2   
 3   
 4   
 5   
 6

### 1 Basic Code

**ICEBL556** - Cartridges and body

### 2 Adjustment Means

**F** - Screw adjustment  
 For fixed versions add setting in 10 bar increments to end of part number. Subject to a +/-10% tolerance.

### 3 Port Size

**5/4** - 1 1/4" SAE Flange cylinder port  
 1 1/4" SAE Flange valve port  
 1/4" BSP all other ports

### 4 SAE Port Type

**6** - SAE 6000

### 5 Pressure Range @ 4.8 L/min

**Note:** Code based on pressure in bar.  
**40** - 70-400 bar.  
 Std setting 350 bar  
 Std setting made at 4.8 L/min

### 6 Seals

**P** - Contains polyurethane and standard seal.

## Dimensions

mm (inch)

### Complete Valve

Flange Mounted  
 Basic Code  
 1CEBL356

**Note:** Cylinder port bolt holes are slotted for fitment to both SAE 3000 & SAE 6000 mounting faces.

**Note:** Tightening torque of "F" adjuster locknut - 20 to 25 Nm.

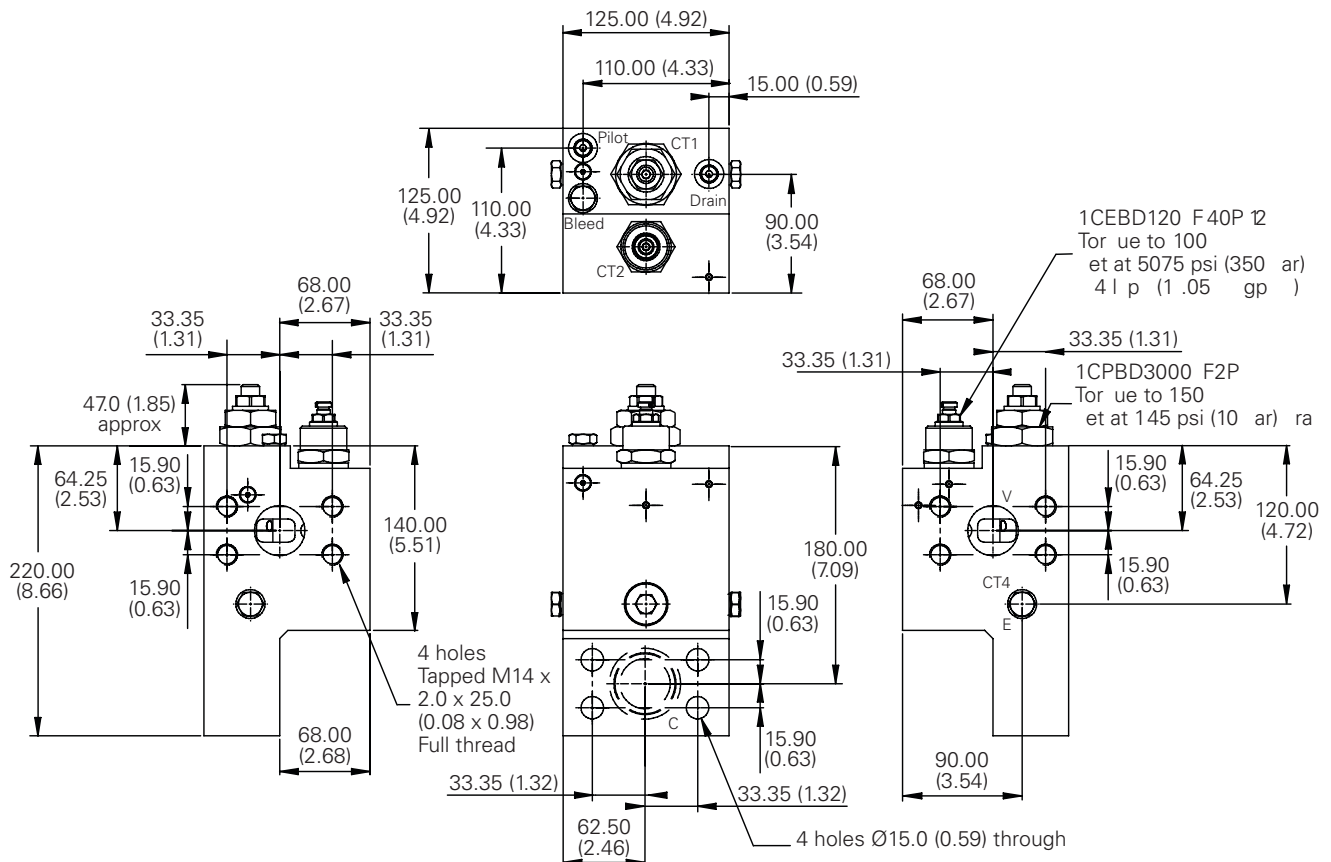

Where measurements are critical request certified drawings. We reserve the right to change specifications without notice.

# ICEBL31 - BoomLoc Valve

Hose burst protection, line mounted with independent pilot control (Ref. ISO 8643)

30 L/min (8 USgpm) • 350 bar (5000 psi)

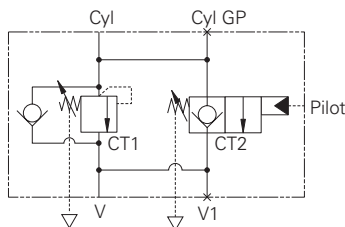

Typical Circuit

## Operation

By connecting the hose rupture valve pilot in parallel with the directional spool valve pilot, and adjusting the opening characteristics of the hose rupture valve to suit that of the spool valve "BoomLoc" may be set so as not to interfere with the normal

operation of the machine.

Fine adjustment of the pilot pressure permits the optimum setting to be made in differing operating systems.

Both the pilot and the relief sections are unaffected by backpressure, enabling the service line reliefs to operate normally. In the event of hose failure, the control will be passed from the main spool to the "BoomLoc" valve, maintaining control of the cylinder.

Regardless of the load the pilot pressure requirement remains constant as the valve is unaffected by load induced pressure, the poppet being fully balanced with zero differential area.

## Features

This is a compact design with good dirt tolerance. Hardened poppets and seats provide excellent load holding characteristics with all the advantages of the cartridge insert.

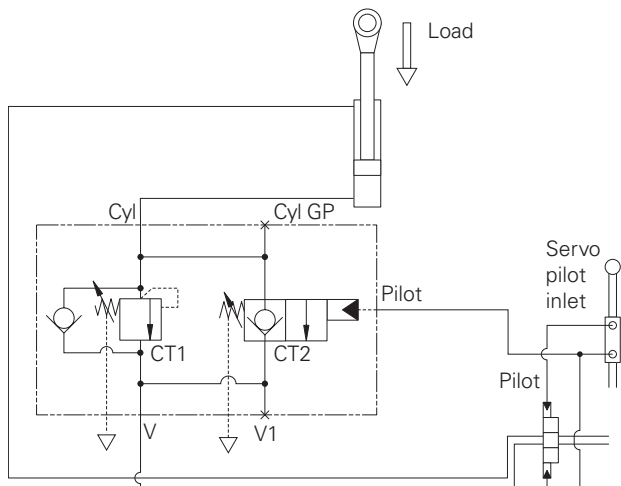

## Description

These overcenter valves are suitable for use on the boom and dipper cylinders of an excavator to help the manufacturer or user comply with standard ISO8643.

They were designed to give relief, load holding and hose failure protection to systems where a pilot system controls the directional valves.

## Performance Data

### Ratings and Specifications

Figures based on: Oil Temp = 40°C Viscosity = 32 cSt (150 SUS)

Rated flow	30 L/min (8 USgpm)
Max setting	350 bar (5000 psi)
Cartridge material	Working parts hardened and ground steel. External surfaces electroless nickel plated and passivated.
Standard housing materials	Bright drawn M.S. bar zinc plated and passivated
Mounting position	Line mounted
Weight	2 kg (4.4 lbs)
Seal kit	SK1164P (Polyurethane/Nitrile)
Filtration	BS5540/4 Class 18/13 (25 micron nominal)
Temperature range	-30° to 90°C (-22° to +194°F)
Internal leakage	0.6 ml/min (10 dpm)
Nominal viscosity range	5 to 500 cSt

# ICEBL31 - BoomLoc Valve

Hose burst protection, line mounted with independent pilot control (Ref. ISO 8643)  
 30 L/min (8 USgpm) • 350 bar (5000 psi)

## Model Code

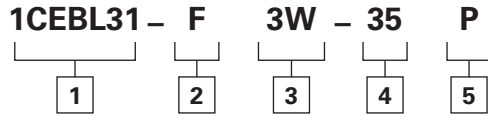

### 1 Basic Code

**1CEBL31** - Cartridges and body

### 2 Adjustment Means

**F** - Screw adjustment

For fixed versions add setting in 10 bar increments to end of part number. Subject to a +/-10% tolerance.

### 3 Port Size

**3W** - 3/8" BSP cylinder port  
 3/8" BSP valve port  
 1/4" BSP all other ports

### 4 Pressure Range @ 4.8 L/min

**Note:** Code based on pressure in bar.

**35** - 70-350 bar.  
 Std setting 240 bar

### 5 Seals

**P** - Contains polyurethane and standard seal.

## Dimensions

mm (inch)

## Complete Valve

Line Mounted (Ref ISO 8643)  
 Basic Code  
 1CEBL31

**Note:** Tightening torque of "F" adjuster locknut - 20 to 25 Nm.

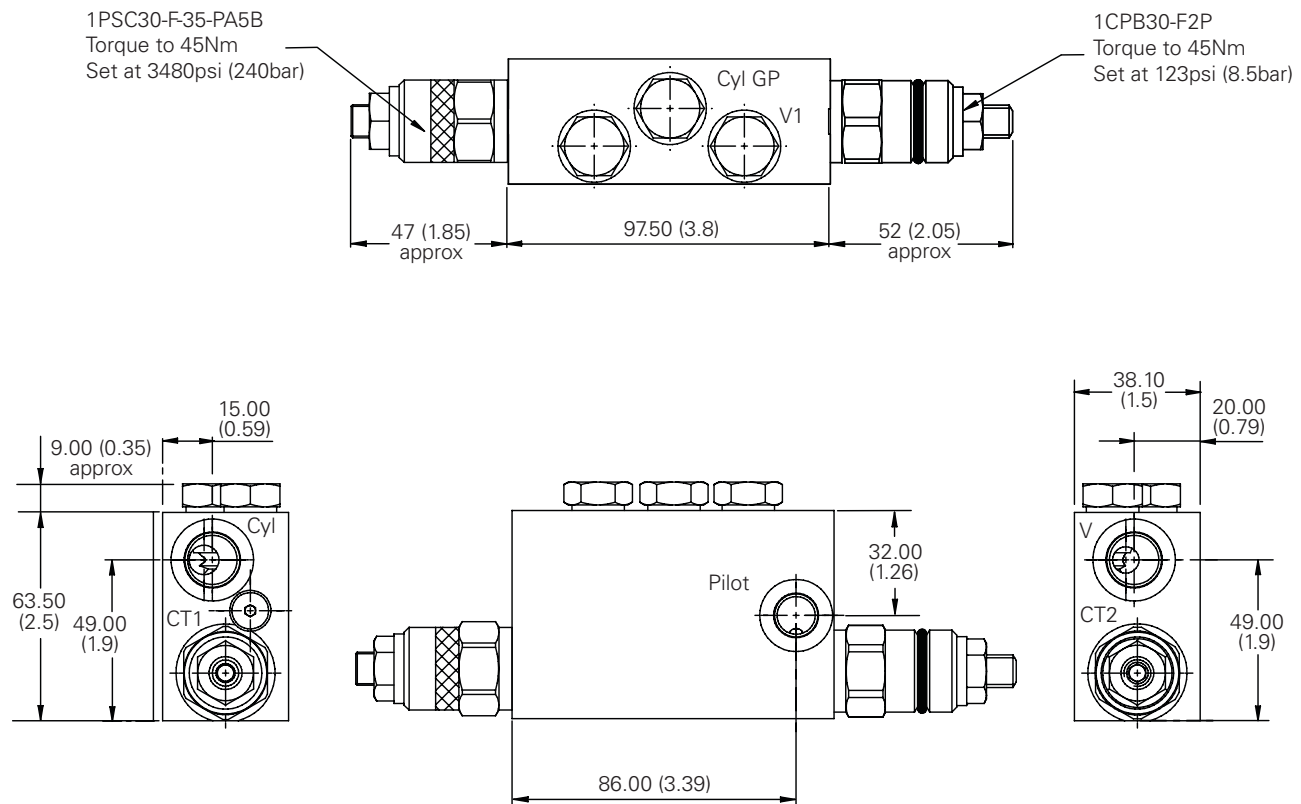

Where measurements are critical request certified drawings. We reserve the right to change specifications without notice.

# ICEBL31 - BoomLoc Valve

Hose burst protection, flange mounted with independent pilot control (Ref. ISO 8643)

30 L/min (8 USgpm) • 350 bar (5000 psi)

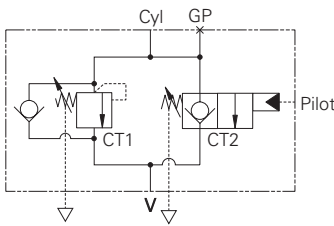

## Operation

By connecting the hose rupture valve pilot in parallel with the directional spool valve pilot, and adjusting the opening characteristics of the hose rupture valve to suit that of the spool valve "BoomLoc" may be set so as not to

interfere with the normal operation of the machine. Fine adjustment of the pilot pressure permits the optimum setting to be made in differing operating systems.

Both the pilot and the relief sections are unaffected by backpressure, enabling the service line reliefs to operate normally. In the event of hose failure, the control will be passed from the main spool to the "BoomLoc" valve, maintaining control of the cylinder.

Regardless of the load the pilot pressure requirement remains constant as the valve is unaffected by load induced pressure, the poppet being fully balanced with zero differential area.

## Features

This is a compact design with good dirt tolerance. Hardened poppets and seats provide excellent load holding characteristics with all the advantages of the cartridge insert.

## Typical Circuits

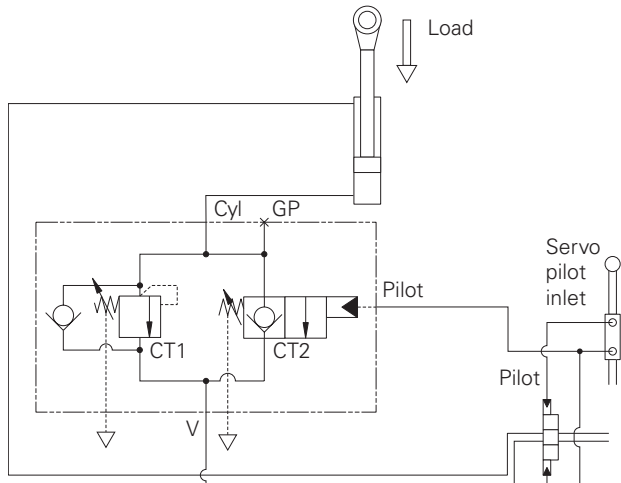

F

## Description

These overcenter valves are suitable for use on the boom and dipper cylinders of an excavator to help the manufacturer or user comply with standard ISO8643.

They were designed to give relief, load holding and hose failure protection to systems where a pilot system controls the directional valves.

## Performance Data

### Ratings and Specifications

Figures based on: Oil Temp = 40°C Viscosity = 32 cSt (150 SUS)

Rated flow	30 L/min (8 USgpm)
Max setting	350 bar (5000 psi)
Cartridge material	Working parts hardened and ground steel. External surfaces electroless nickel plated and passivated.
Standard housing materials	Bright drawn M.S. bar zinc plated and passivated
Mounting position	Flange mounted
Weight	2 kg (4.4 lbs)
Seal kit	SK1165P (Polyurethane/Nitrile)
Filtration	BS5540/4 Class 18/13 (25 micron nominal)
Temperature range	-30° to +90°C (-22° to +194°F)
Internal leakage	0.6 ml/min (10 dpm)
Nominal viscosity range	5 to 500 cSt

# ICEBL31 - BoomLoc Valve

Hose burst protection, flange mounted with independent pilot control (Ref. ISO 8643)

30 L/min (8 USgpm) • 350 bar (5000 psi)

## Model Code

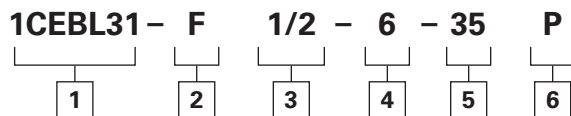

### 1 Basic Code

**1CEBL31** - Cartridges and body

### 2 Adjustment Means

**F** - Screw adjustment

For fixed versions add setting in 10 bar increments to end of part number. Subject to a ±10% tolerance.

### 3 Port Size

**1/2** - 1/2" SAE flange  
3/8" BSP valve port  
1/4" BSP all other ports

### 4 SAE Port Type

**6** - SAE 6000

### 5 Pressure Range @ 4.8 L/min

**Note:** Code based on pressure in bar.

**35** - 70-350 bar.  
Std setting 240 bar

Std setting made at 4.8 L/min

### 6 Seals

**P** - Contains polyurethane and standard seal.

## Dimensions

mm (inch)

### Complete Valve

Flange Mounted  
Basic Code  
1CEBL31

**Note:** Tightening torque of "F" adjuster locknut - 20 to 25 Nm.

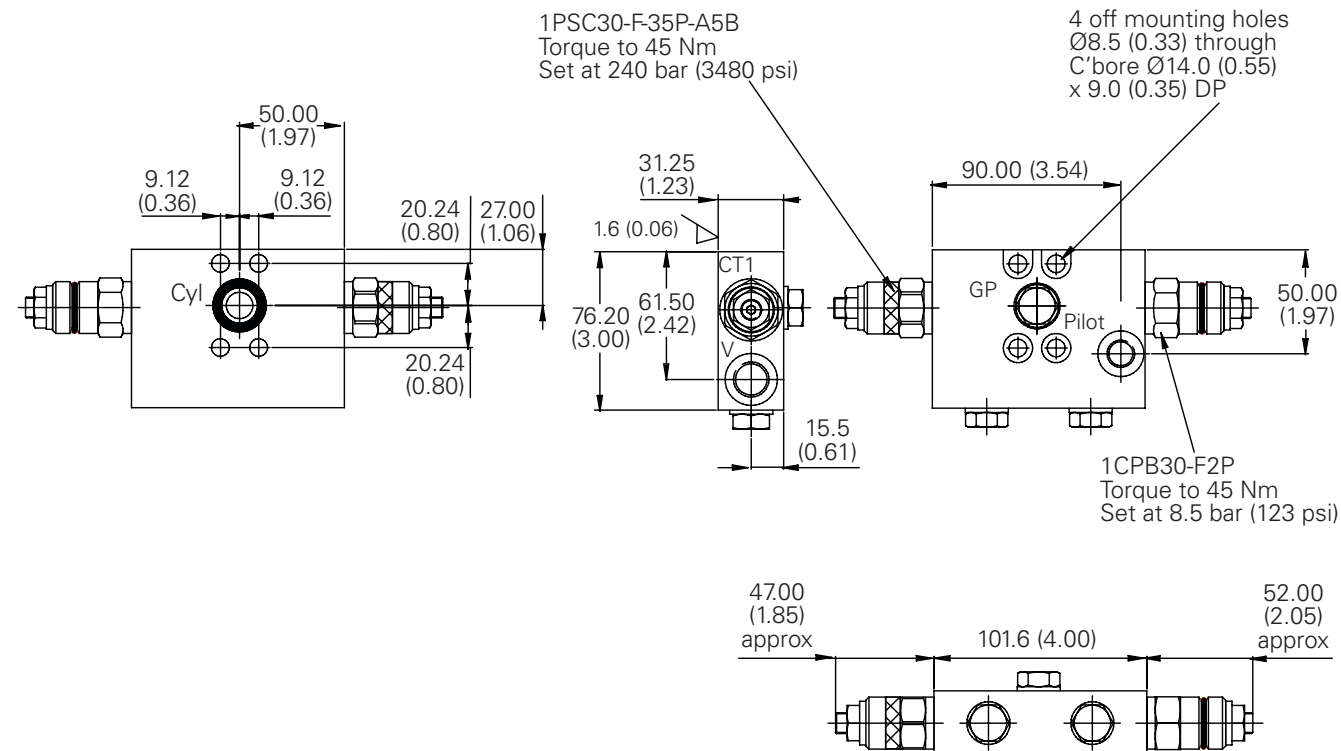

Where measurements are critical request certified drawings. We reserve the right to change specifications without notice.



# ICEBL31 - BoomLoc Valve

Hose burst protection, line mounted with independent pilot control (Ref. ISO 8643)

30 L/min (8 USgpm) • 350 bar (5000 psi)

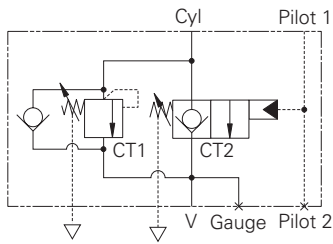

## Operation

By connecting the hose rupture valve pilot in parallel with the directional spool valve pilot, and adjusting the opening characteristics of the hose rupture valve to suit that of the spool valve "BoomLoc"

may be set so as not to interfere with the normal operation of the machine. Fine adjustment of the pilot pressure permits the optimum setting to be made in differing operating systems.

Both the pilot and the relief sections are unaffected by backpressure, enabling the service line reliefs to operate normally. In the event of hose failure, the control will be passed from the main spool to the "BoomLoc" valve, maintaining control of the cylinder.

Regardless of the load the pilot pressure requirement remains constant as the valve is unaffected by load induced pressure, the poppet being fully balanced with zero differential area.

## Features

This is a compact design with good dirt tolerance. Hardened poppets and seats provide excellent load holding characteristics with all the advantages of the cartridge insert.

## Typical Circuit

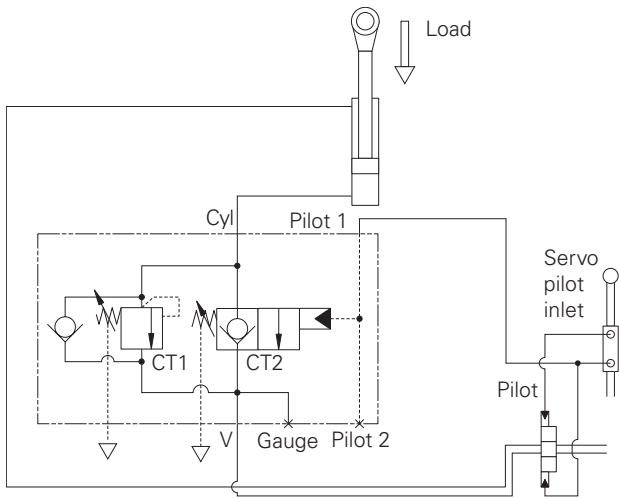

F

## Description

These overcenter valves are suitable for use on the boom and dipper cylinders of an excavator to help the manufacturer or user comply with standard ISO8643.

They were designed to give relief, load holding and hose failure protection to systems where a pilot system controls the directional valves.

## Performance Data

### Ratings and Specifications

*Figures based on: Oil Temp = 40°C Viscosity = 32 cSt (150 SUS)*

Rated flow	30 L/min (8 USgpm)
Max setting	350 bar (5000 psi)
Cartridge material	Working parts hardened and ground steel. External surfaces electroless nickel plated and passivated.
Standard housing materials	Bright drawn M.S. bar zinc plated and passivated
Mounting position	Line mounted
Weight	2 kg (4.4 lbs)
Seal kit	SK1164P (Polyurethane/Nitrile)
Filtration	BS5540/4 Class 18/13 (25 micron nominal)
Temperature range	-30° to 90°C (-22° to +194°F)
Internal leakage	0.6 ml/min (10 dpm)
Nominal viscosity range	5 to 500 cSt

Where measurements are critical request certified drawings. We reserve the right to change specifications without notice.

# ICEBL31 - BoomLoc Valve

Hose burst protection, line mounted with independent pilot control (Ref. ISO 8643)  
 30 L/min (8 USgpm) • 350 bar (5000 psi)

## Model Code

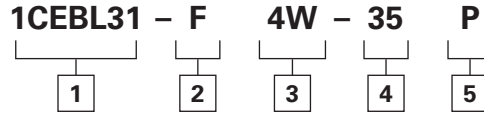

### 1 Basic Code

**1CEBL31** - Cartridges and body

### 2 Adjustment Means

**F** - Screw adjustment

For fixed versions add setting in 10 bar increments to end of part number. Subject to a ±10% tolerance.

### 3 Port Size

**4W** - 1/2" BSP cylinder port  
 1/2" BSP valve port  
 1/4" BSP all other ports

### 4 Pressure Range @ 4.8 L/min

**Note:** Code based on pressure in bar.

**35** - 70-350 bar.  
 Std setting 280 bar

Std setting made at 4.8 L/min

### 5 Seals

**P** - Contains polyurethane and standard seal.

## Dimensions

mm (inch)

## Complete Valve

Line Mounted  
 Basic Code  
 1CEBL31

**Note:** Tightening torque of "F" adjuster locknut - 20 to 25 Nm.

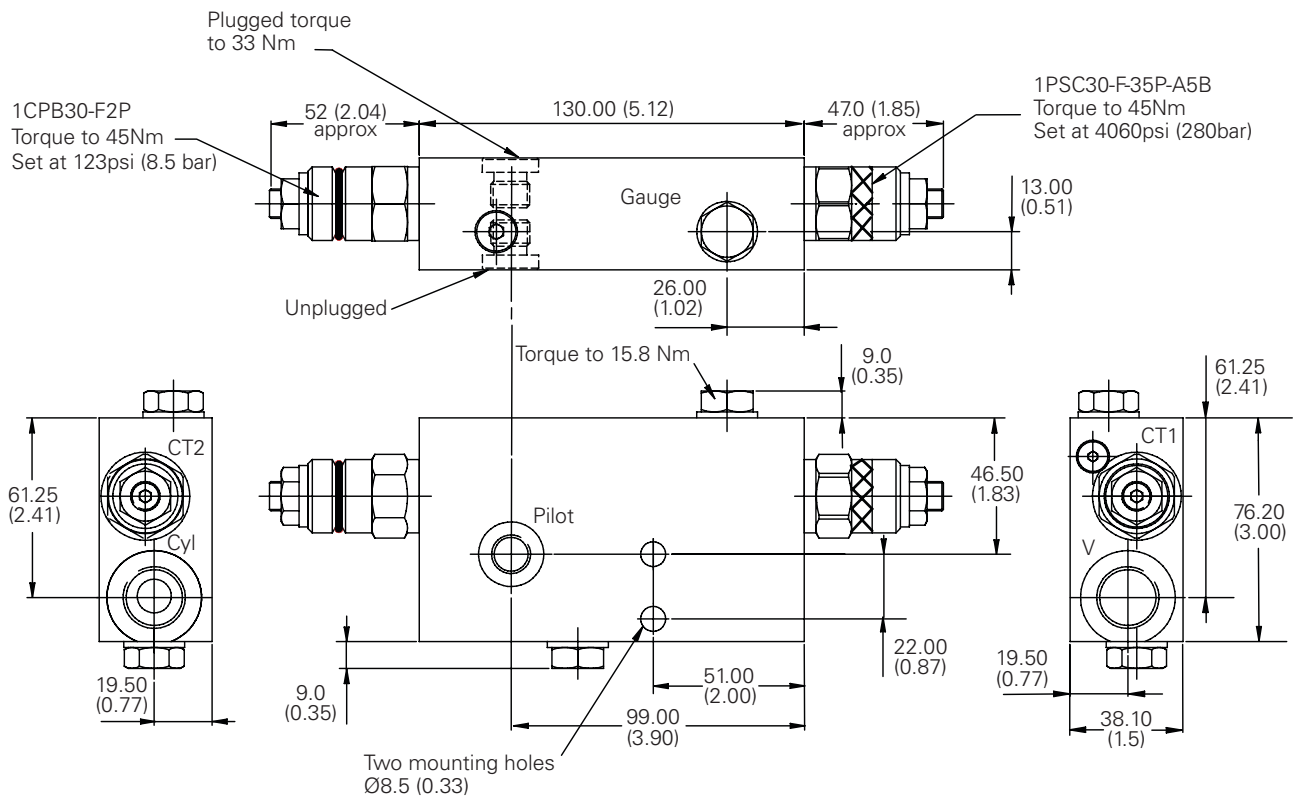

Where measurements are critical request certified drawings. We reserve the right to change specifications without notice.



# ICEBL91 - BoomLoc Valve

Hose burst protection, line mounted with independent pilot control (Ref. ISO 8643)

90 L/min (24 USgpm) • 350 bar (5000 psi)

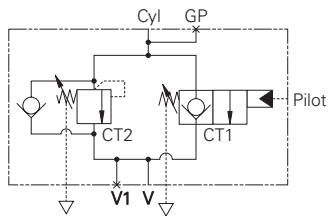

## Operation

By connecting the hose rupture valve pilot in parallel with the directional spool valve pilot, and adjusting the opening characteristics of the hose rupture valve to suit that

of the spool valve "BoomLoc" may be set so as not to interfere with the normal operation of the machine. Fine adjustment of the pilot pressure permits the optimum setting to be made in differing operating systems.

## Features

This is a compact design with good dirt tolerance. Hardened poppets and seats provide excellent load holding characteristics with all the advantages of the cartridge insert.

Both the pilot and the relief sections are unaffected by backpressure, enabling the service line reliefs to operate normally. In the event of hose failure, the control will be passed from the main spool to the "BoomLoc" valve, maintaining control of the cylinder.

Regardless of the load the pilot pressure requirement remains constant as the valve is unaffected by load induced pressure, the poppet being fully balanced with zero differential area.

## Typical Circuit

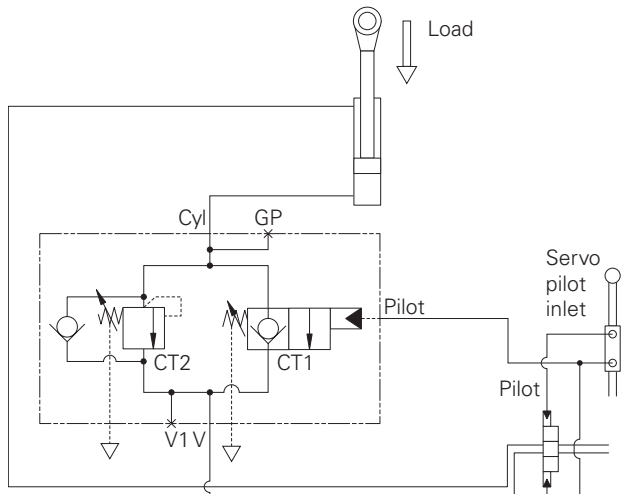

F

## Description

These overcenter valves are suitable for use on the boom and dipper cylinders of an excavator to help the manufacturer or user comply with standard ISO8643.

They were designed to give relief, load holding and hose failure protection to systems where a pilot system controls the directional valves.

## Performance Data

### Ratings and Specifications

Figures based on: Oil Temp = 40°C Viscosity = 32 cSt (150 SUS)

Rated flow	90 L/min (24 USgpm)
Max setting	350 bar (5000 psi)
Cartridge material	Working parts hardened and ground steel. External surfaces electroless nickel plated and passivated.
Standard housing materials	Bright drawn M.S. bar zinc plated and passivated
Mounting position	Line mounted
Weight	3.5 kg (7.7 lbs)
Seal kit	SK1166P (Polyurethane/Nitrile)
Filtration	BS5540/4 Class 18/13 (25 micron nominal)
Temperature range	-30° to 90°C (-22° to +194°F)
Internal leakage	0.6 ml/min (10 dpm)
Nominal viscosity range	5 to 500 cSt

Where measurements are critical request certified drawings. We reserve the right to change specifications without notice.

# ICEBL91 - BoomLoc Valve

Hose burst protection, line mounted with independent pilot control (Ref. ISO 8643)  
 90 L/min (24 USgpm) • 350 bar (5000 psi)

## Model Code

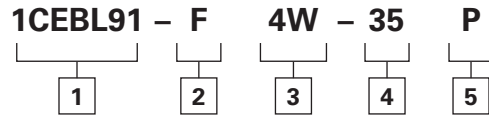

### 1 Basic Code

**1CEBL91** - Cartridges and body

### 2 Adjustment Means

**F** - Screw adjustment

For fixed versions add setting in 10 bar increments to end of part number. Subject to a ±10% tolerance.

### 3 Port Size

**4W** - 1/2" BSP cylinder port  
 1/2" BSP valve port "V"  
 1/4" BSP "V1" & all other ports

### 4 Pressure Range @ 4.8 L/min

**Note:** Code based on pressure in bar.

**35** - 70-350 bar.

Std setting 280 bar

Std setting made at 4.8 L/min

### 5 Seals

**P** - Contains polyurethane and standard seal.

## Dimensions

mm (inch)

### Complete Valve

Line Mounted

Basic Code

1CEBL91

**Note:** Tightening torque of "F" adjuster locknut - 20 to 25 Nm.

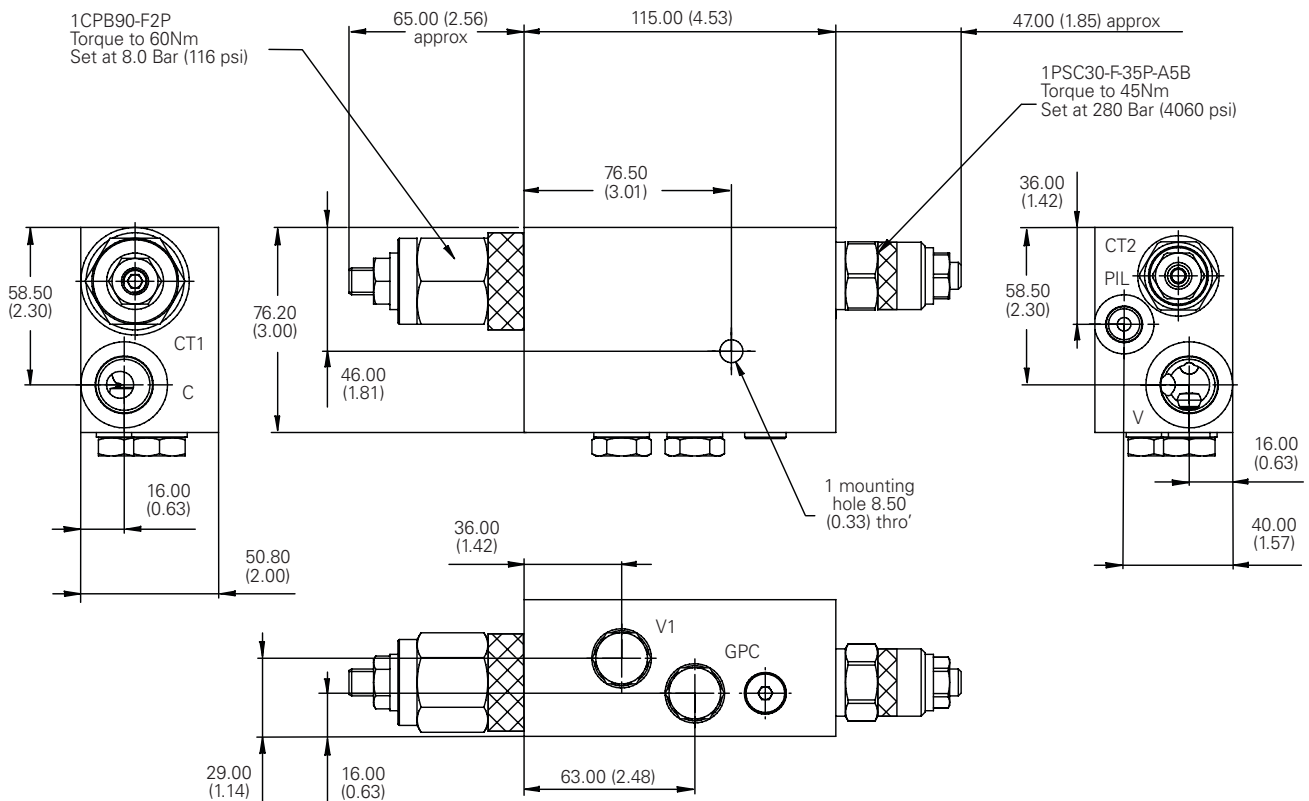

Where measurements are critical request certified drawings. We reserve the right to change specifications without notice.

# ICEBL151 - BoomLoc Valve

Hose burst protection, line mounted with independent pilot control (Ref. ISO 8643)

150 L/min (40 USgpm) • 350 bar (5000 psi)

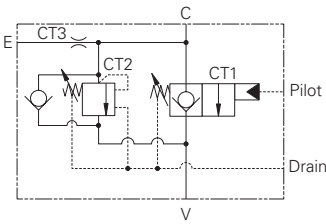

## Operation

By connecting the hose rupture valve pilot in parallel with the directional spool valve pilot, and adjusting the opening characteristics of the hose rupture valve to suit that of the spool valve "BoomLoc"

## Typical Circuit

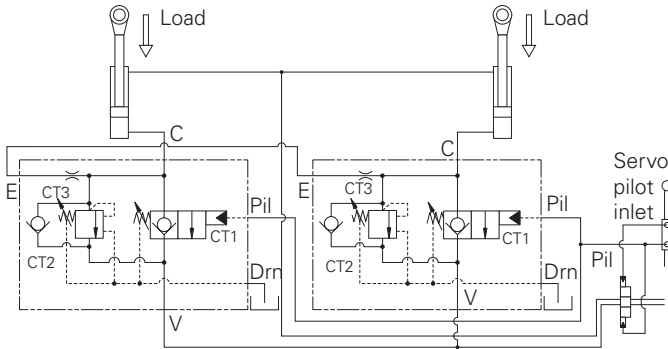

## Features

This is a compact design with good dirt tolerance. Hardened poppets and seats provide excellent load holding characteristics with all the advantages of the cartridge insert.

Both the pilot and the relief sections are unaffected by backpressure, enabling the service line relief's to operate normally. In the event of hose failure, the control will be passed from the main spool to the "BoomLoc" valve, maintaining control of the cylinder.

Regardless of the load the pilot pressure requirement remains constant as the valve is unaffected by load induced pressure, the poppet being fully balanced with zero differential area.

## Description

These overcenter valves are suitable for use on the boom and dipper cylinders of an excavator to help the manufacturer or user comply with standard ISO8643.

They were designed to give relief, load holding and hose failure protection to systems where a pilot system controls the directional valves.

## Performance Data

### Ratings and Specifications

Figures based on: Oil Temp = 40°C Viscosity = 32 cSt (150 SUS)

Rated flow	150 L/min (40 USgpm)
Max setting	350 bar (5000 psi)
Cartridge material	Working parts hardened and ground steel. External surfaces electroless nickel plated and passivated.
Standard housing materials	Bright drawn M.S. bar zinc plated and passivated
Mounting position	Line mounted
Weight	3 kg (6.6 lbs)
Seal kit	SK947P (Polyurethane/Nitrile)
Filtration	BS5540/4 Class 18/13 (25 micron nominal)
Temperature range	-30° to +90°C (-22° to +194°F)
Internal leakage	0.6 ml/min (10 dpm)
Nominal viscosity range	5 to 500 cSt

# ICEBL151 - BoomLoc Valve

Hose burst protection, line mounted with independent pilot control (Ref. ISO 8643)  
 150 L/min (40 USgpm) • 350 bar (5000 psi)

## Model Code

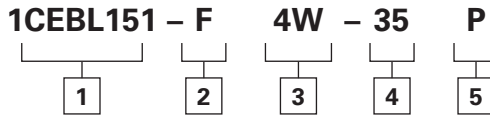

<p><b>1 Basic Code</b>  <b>1CEBL151</b> - Cartridges and body</p>	<p><b>3 Port Size</b>  <b>4W</b> - 1/2" BSP cylinder port                  1/2" BSP valve port                  G1/8" all other ports</p>	<p><b>4 Pressure Range @ 4.8 L/min</b>  <b>35</b> - 70-350 bar.                  Std setting 260 bar                  Std setting made at 4.8 L/min</p>	<p><b>5 Seals</b>  <b>P</b> - Contains polyurethane and standard seal.</p>
<p><b>2 Adjustment Means</b>  <b>F</b> - Screw adjustment                  For fixed versions add setting in 10 bar increments to end of part number. Subject to a ±10% tolerance.</p>			

## Dimensions

mm (inch)

### Complete Valve

Line Mounted  
 Basic Code  
 1CEBL151

**Note:** Tightening torque of "F" adjuster locknut - 20 to 25 Nm.

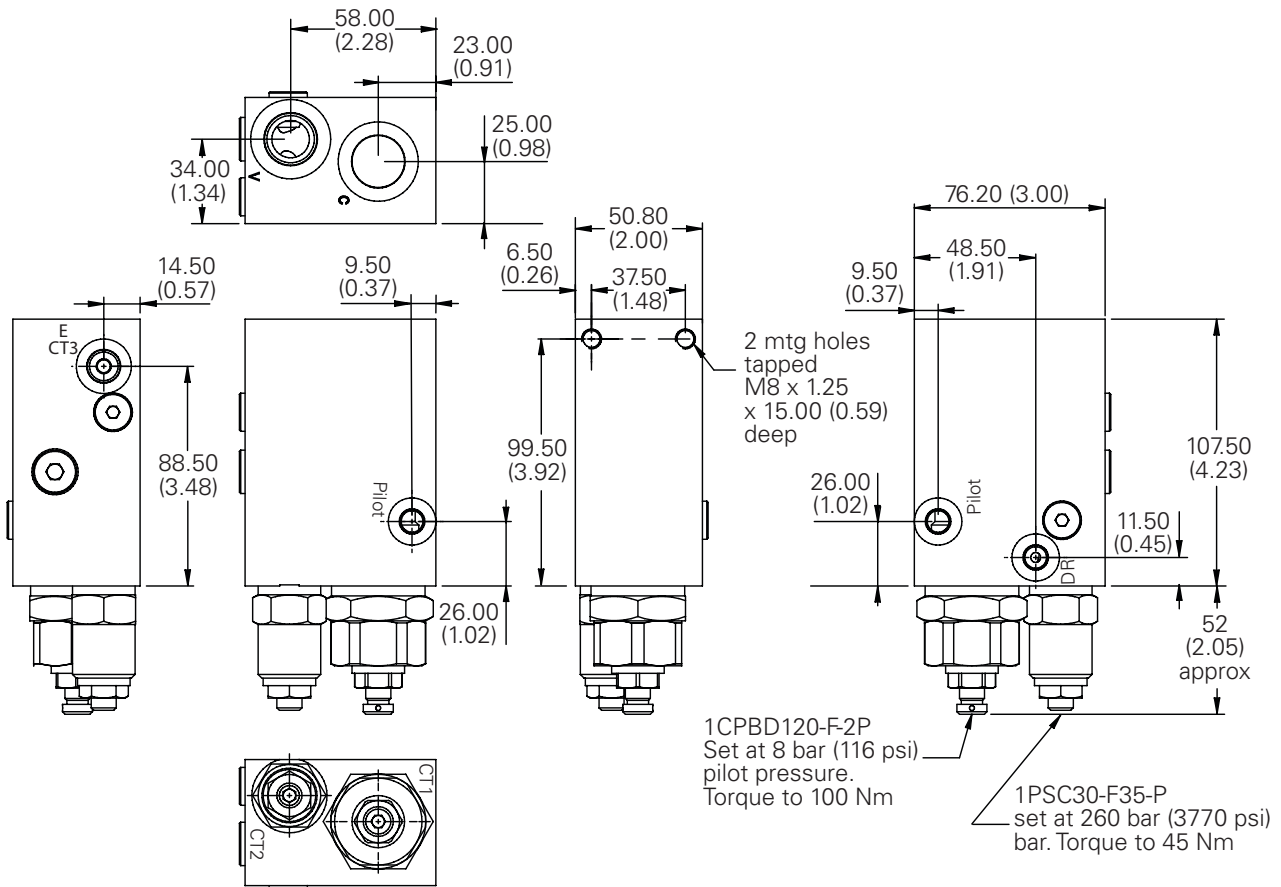

Where measurements are critical request certified drawings. We reserve the right to change specifications without notice.



# ICEBL153 - BoomLoc Valve

Hose burst protection, line mounted with independent pilot control (Ref. ISO 8643)

150 L/min (40 USgpm) • 350 bar (5000 psi)

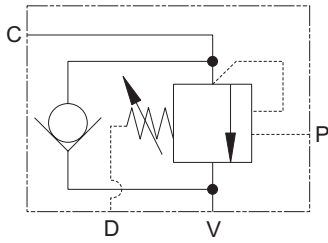

## Operation

By connecting the pilot line in parallel with the spool valve pilot, the high pilot ratio allows the valve to open just prior to the spool valve, ensuring that the valve does not interfere with the normal operation of the machine. Both the pilot

and the relief sections are unaffected by back pressure, enabling the service line reliefs to operate normally, without interfering with the spool valve control as it meters the return flow. In the event of hose failure, the control will be passed from the main spool to the overcenter valve, maintaining control of the cylinder.

The pressure required to open the valve and start actuator movement can be calculated as follows:

$$\text{Pilot Pressure} = \frac{(\text{Relief Setting}) - (\text{Load Pressure})}{\text{Pilot Ratio}}$$

## Features

This is a compact design with good dirt tolerance. Hardened poppets and seats provide excellent load holding characteristics with all the advantages of the cartridge insert.

## Typical Circuit

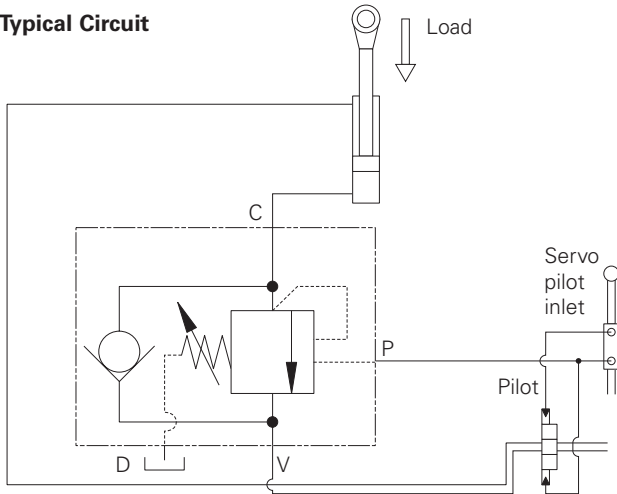

F

## Description

These overcenter valves are suitable for use on the boom and dipper cylinders of an excavator to help the manufacturer or user comply with standard ISO8643.

They were designed to give relief, load holding and hose failure protection to systems where a pilot system controls the directional valves.

## Performance Data

### Ratings and Specifications

*Figures based on: Oil Temp = 40°C Viscosity = 32 cSt (150 SUS)*

Rated flow	150 L/min (40 USgpm)
Max setting	350 bar (5000 psi)
Cartridge material	Working parts hardened and ground steel. External surfaces electroless nickel plated and passivated.
Standard housing materials	Bright drawn M.S. bar zinc plated and passivated
Mounting position	Mount directly to cylinder using steel pipe
Weight	1.5 kg (3.3 lbs)
Seal kit	SK924P
Filtration	BS5540/4 Class 18/13 (25 micron nominal)
Temperature range	-30° to +90°C (-22° to +194°F)
Internal leakage	1.5 ml/min
Nominal viscosity range	5 to 500 cSt

# 1CEBL153 - BoomLoc Valve

Hose burst protection, line mounted with independent pilot control (Ref. ISO 8643)

150 L/min (40 USgpm) • 350 bar (5000 psi)

## Model Code

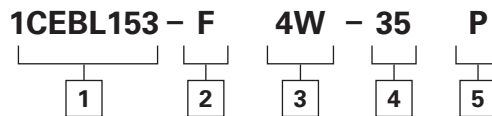

### 1 Basic Code

**1CEBL153** - Cartridges and body

### 2 Adjustment Means

**F** - Screw adjustment

For fixed versions add setting in 10 bar increments to end of part number. Subject to a  $\pm 10\%$  tolerance.

### 3 Port Size

**4W** - 1/2" BSP cylinder port  
1/2" BSP valve port  
1/4" BSP pilot port/drain port

### 4 Pressure Range @ 4.8 L/min

**Note:** Code based on pressure in bar.

**35** - 70-350 bar.  
Std setting 350 bar

Std setting made at 4.8 L/min

### 5 Seals

**P** - Contains polyurethane and standard seal.

## Dimensions

mm (inch)

### Complete Valve

Line Mounted  
Basic Code  
1CEBL153

**Note:** Tightening torque of "F" adjuster locknut - 20 to 25 Nm.

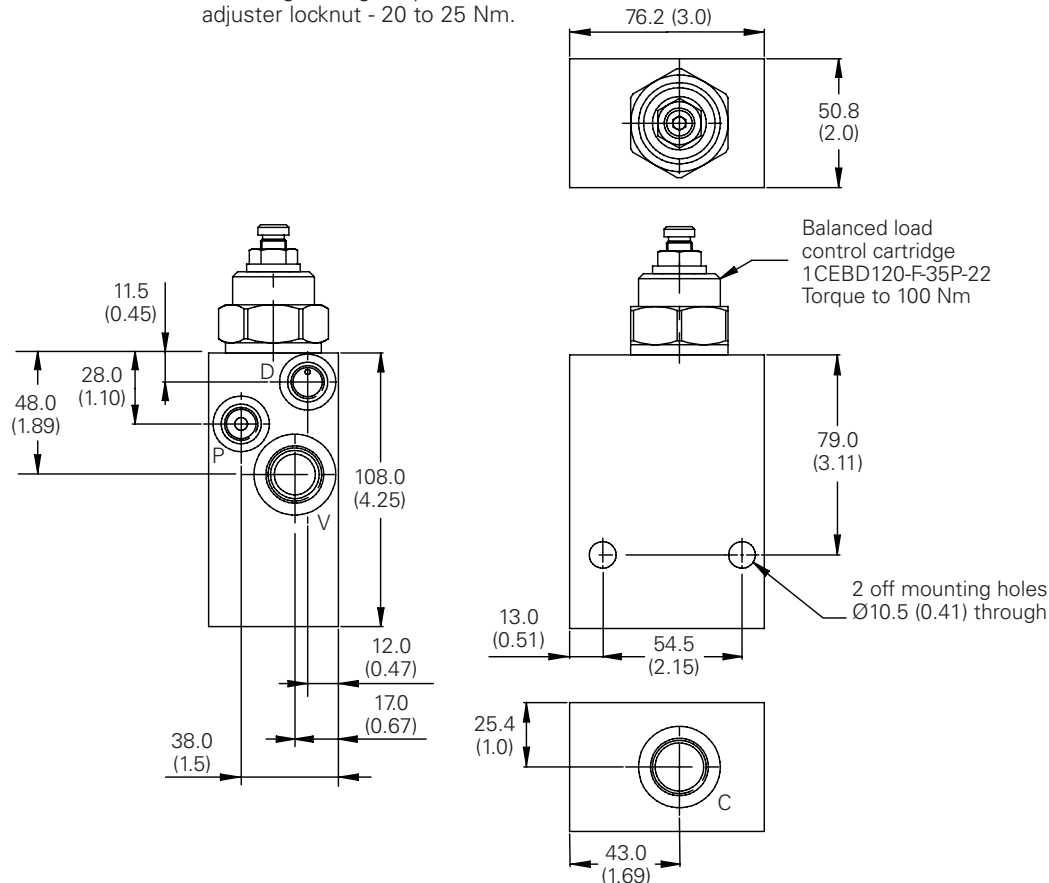

Where measurements are critical request certified drawings. We reserve the right to change specifications without notice.



**Problem:**  
Need More Power?

**Solution:**  
Get Eaton's 760 Series  
Pumps and Motors!

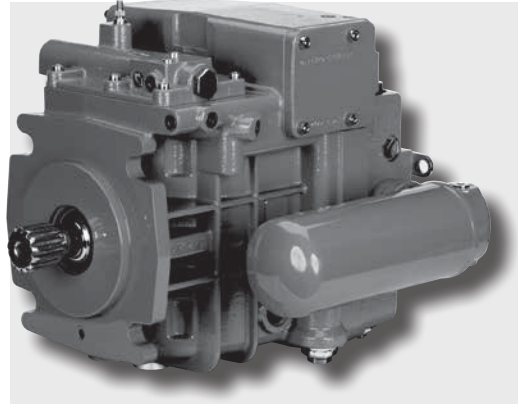

For power when you need it.

Mining and aggregate applications require continuous operation in demanding, power-hungry jobs. You need power and performance. Get both with Eaton's 760 Series pumps and motors.

- Robust design
- Multiple, fast-acting controls
- Wide range of fluid capabilities, including water-glycol
- 130-160cm<sup>3</sup>/r (8-10in<sup>3</sup>/r)

© 2009 Eaton Corporation

F

**Problem:**  
White-Knuckled About  
Motor Performance?

**Solution:**  
Get Eaton's Char-Lynn<sup>®</sup>  
Hydraulic Motors!

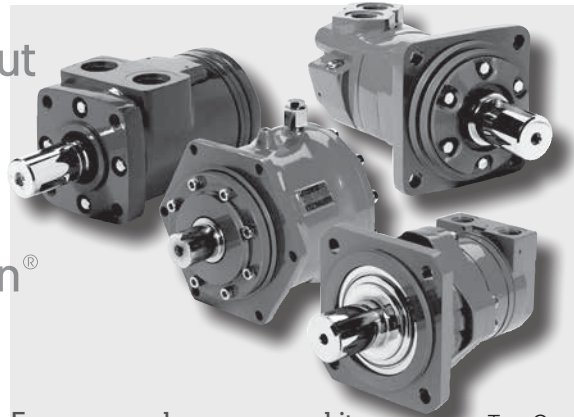

For power when you need it.

Warehouse and logistics applications require continuous operation. Your job depends on it. This is no place for downtime. Get Eaton's Char-Lynn<sup>®</sup> proven hydraulic motors to keep your business running.

- Top Quality
- Robust design
- Efficient performance
- Wide range of fluid capabilities
- Displacements up to 950cm<sup>3</sup>/r (58in<sup>3</sup>/r)

© 2009 Eaton Corporation